

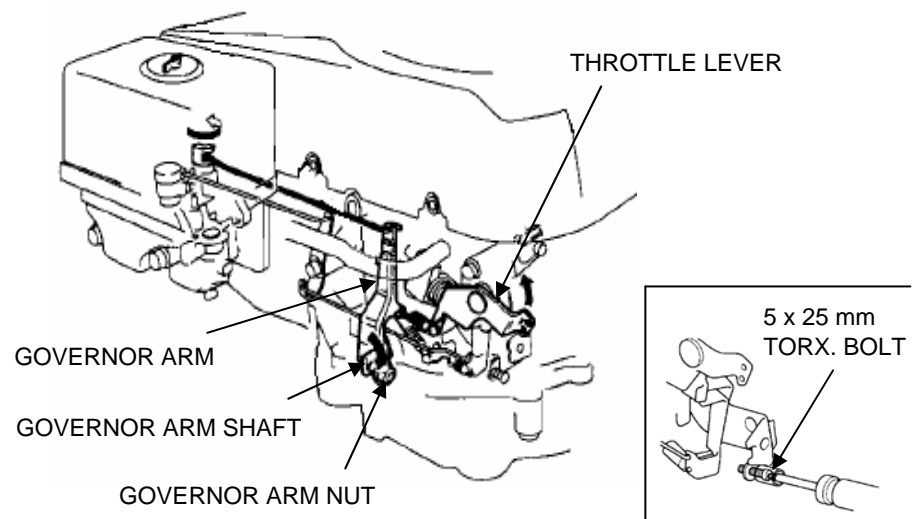

**GOVERNOR**

- ①. Remove the fuel tank.
- ②. Loosen the governor arm nut and move the governor arm to fully open the throttle.
- ③. Rotate the governor arm shaft as far as it will go in the same direction the governor arm moved to open the throttle. Tighten the governor arm nut.
- ④. Start the engine and allow it to warm up to normal operating temperature. Move the throttle lever to run the engine at the standard maximum speed.  
If the engine maximum speed is out of the specification, adjust the engine speed by turning the 5 x 25 mm torx. bolt.  
Maximum speed: **3,300 ± 150 min<sup>-1</sup> (rpm)**



**VALVE CLEARANCE**

Valve clearance inspection and adjustment must be performed with the engine cold.

- ①. Remove the cylinder head cover and recoil starter.
- ②. Turn the crankshaft and set the piston at top dead center of the compression stroke (both valves fully closed).  
The storage mark on the starter pulley will align with the align mark on the fan cover when the piston is at top dead center of the compression stroke or exhaust stroke.
- ③. Insert the thickness gauge between the rocker arm and valve to measure valve clearance.  
VALVE CLEARANCE: **0.15 ± 0.02 mm (IN)**  
**0.20 ± 0.02 mm (EX)**
- ④. If adjustment is necessary, proceed as follows:
  - a. Hold the rocker arm pivot and loosen the rocker arm pivot lock nut.
  - b. Turn the rocker arm pivot to obtain the specified clearance.
  - c. Retighten the rocker arm pivot lock nut while holding the rocker arm pivot.  
TORQUE: **10 N·m (1.0 kgf·m, 7 lbf·ft)**  
Recheck valve clearance after tightening the rocker arm pivot lock nut.

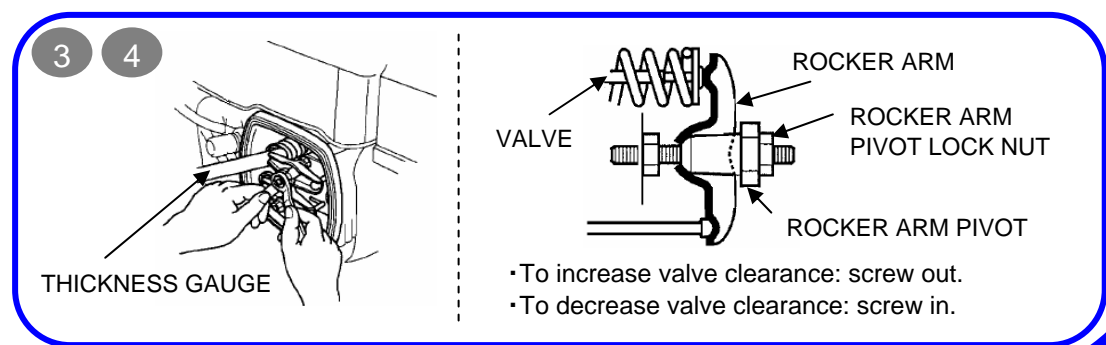
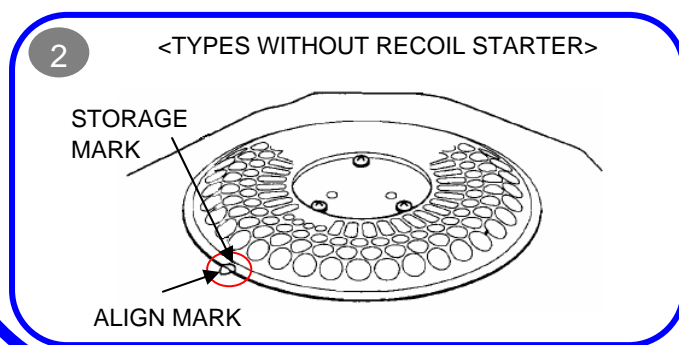
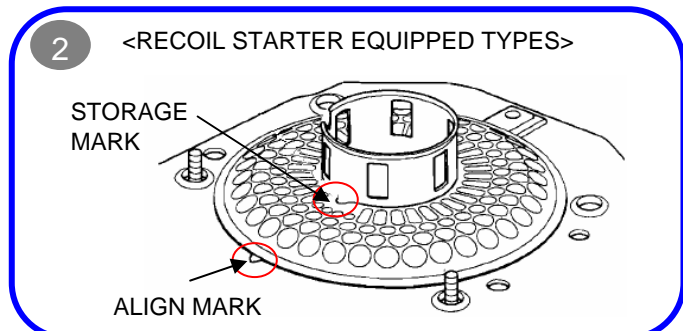
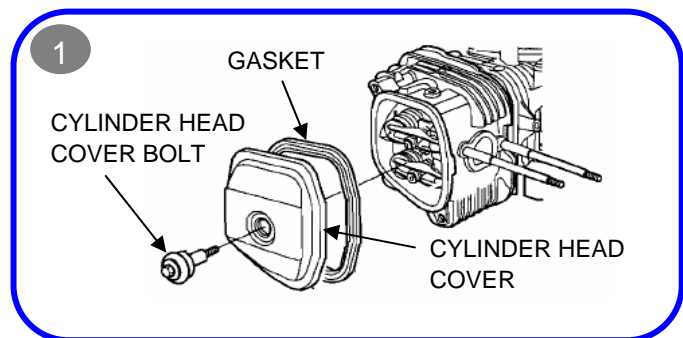

**IGNITION COIL AIR GAP**

- ①. Loosen the ignition coil mounting bolts.
- ②. Insert the thickness gauge of proper thickness between the ignition coil and flywheel.
- ③. Push the ignition coil firmly against the flywheel and tighten the ignition coil mounting bolt. Remove the thickness gauge.  
SPECIFIED GAP: **0.4 ± 0.2 mm (0.016 ± 0.008 in)**

NOTE: Avoid the magnet part of the flywheel when adjusting.  
Adjust the gap equally at both ends of the ignition coil.

