

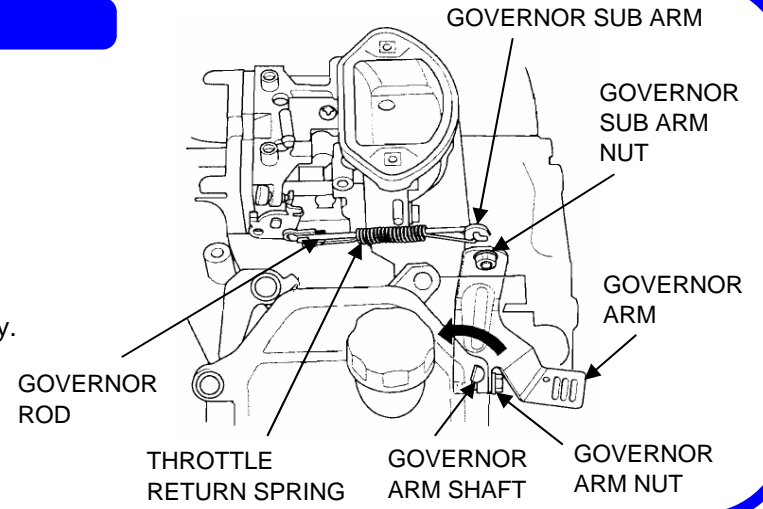

GOVERNOR (Without auto throttle type)

- ①. Install the governor arm on the governor arm shaft by aligning the cutout.
- ②. Tighten the governor arm nut.
TORQUE: **11 N·m (1.1 kgf·m, 8 lbf·ft)**
- ③. Connect the governor rod and throttle return spring to the governor arm and carburetor.
- ④. Loosen the governor sub arm nut.
- ⑤. Rotate the governor arm counterclockwise to fully open the carburetor throttle valve.
- ⑥. Rotate the governor sub arm counterclockwise as far as it will go.
- ⑦. Hold the governor arm and governor sub arm, tighten the governor sub arm nut securely.



VALVE CLEARANCE

NOTE: Valve clearance inspection and adjustment must be performed with the engine cold.

- ①. Remove the four flange bolts and each valve cover. Remove the fan cover protector or screen grid. Disconnect the spark plug caps from the spark plugs.
- ②. Set the piston of the No. 1 cylinder at top dead center of the cylinder compression stroke (both valves fully closed) by rotating the flywheel clockwise slowly. When the No. 1 piston is at top dead center of the compression stroke, the "T" mark on the cooling fan will align with the right side alignment mark on the fan cover. If the exhaust valve is opened, rotate the flywheel and align the "T" mark on the cooling fan with the alignment mark on the fan cover again.
- ③. Insert a thickness gauge between the valve rocker arm and valve stem to measure the valve clearance.
VALVE CLEARANCE: **0.08 ± 0.02 mm (IN) 0.10 ± 0.02 mm (EX)**
- ④. Set the piston of the No. 2 cylinder at top dead center of the cylinder compression stroke (both valves fully closed) by rotating the flywheel 270 degrees clockwise slowly. When the No. 2 piston is at top dead center of the compression stroke, the "T" mark on the cooling fan will align with the left side alignment mark on the fan cover.
- ⑤. Insert a thickness gauge between the valve rocker arm and valve stem to measure the valve clearance.
- ⑥. If adjustment is necessary, proceed as follows:
 - a. Hold the tappet adjusting screw and loosen the tappet adjusting nut.
TOOL: Tappet adjusting wrench 3 mm 07708-0030400
 - b. Turn the tappet adjusting screw to obtain the specified clearance.
 - c. Hold the tappet adjusting screw and retighten the tappet adjusting nut to the specified torque. TORQUE: **7.5 N·m (0.75 kgf·m, 5.4 lbf·ft)**
- ⑦. Recheck the valve clearance, and if necessary, readjust the clearance. Check the valve cover packing for damage or deterioration and install it on the valve cover. Attach the cylinder valve cover to the cylinder and tighten the flange bolts securely.

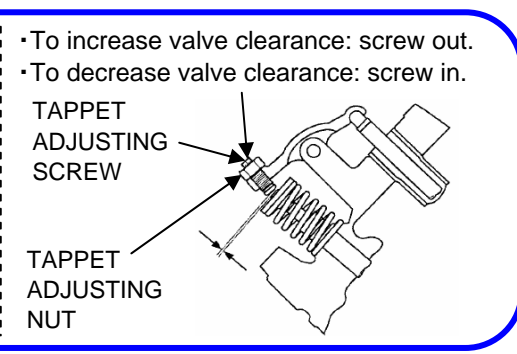
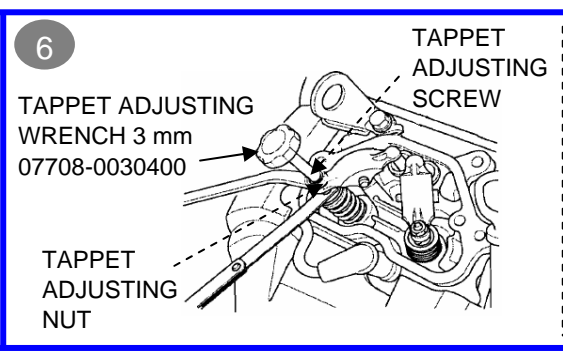
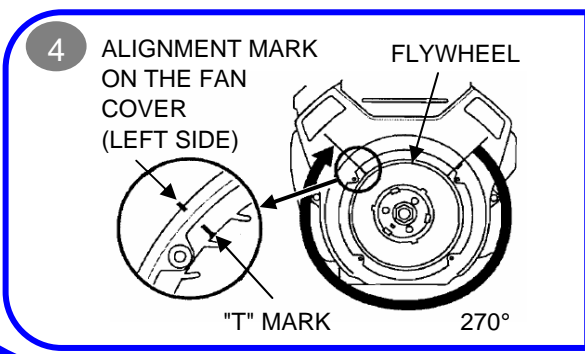
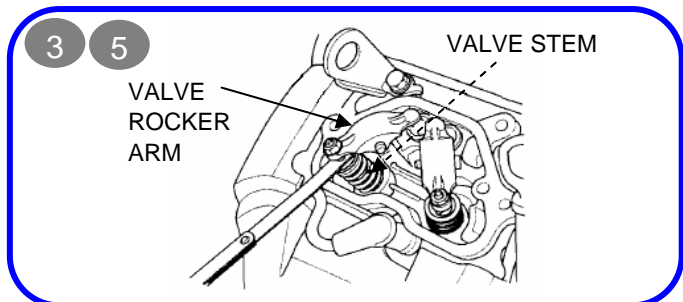
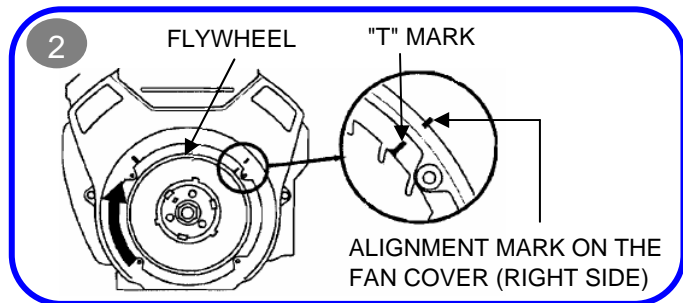
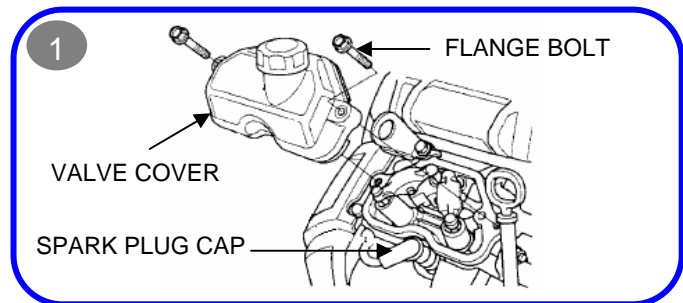

IGNITION COIL AIR GAP

- ①. Insert the ignition coil and loosely tighten the two flange bolts.
 - ②. Insert the thickness gauge of proper thickness between the ignition coil and the flywheel.
IGNITION COIL AIR GAP: **0.4 ± 0.2 mm (0.016 ± 0.008 in)**
- NOTE: Adjust the ignition coil air gap equally at both sides.
Push the ignition coil firmly against the flywheel and tighten the flange bolts.
Remove the thickness gauge.

