

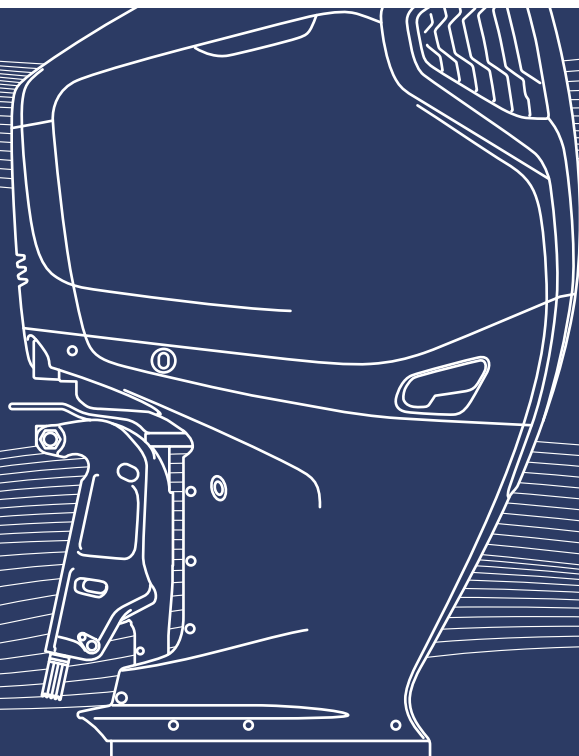

Owner's Manual  
BF300A • BF350A



Original instructions

© 2026 Honda Motor Co., Ltd. - All Rights Reserved



## WARNING:



The engine exhaust from this product contains chemicals known to the State of California to cause cancer, birth defects or other reproductive harm.

Keep this Owner's Manual handy, so you can refer to it at any time. This Owner's Manual is considered a permanent part of the outboard motor and should remain with the outboard motor if resold.

The information and specifications included in this publication were in effect at the time of approval for printing. Honda Motor Co., Ltd. reserves the right, however, to discontinue or change specifications or design at any time without notice and without incurring any obligation whatever. No part of this publication may be reproduced without written permission.

### **Availability of spare parts, repair service and information for maintenance or repair:**

Pursuant to applicable Quebec regulation, Honda does not guarantee the availability of replacement parts, repair services, or information required for the maintenance or repair of this product or its components.

For more information visit: [www.honda.ca/en/quebecregulatorynotice](http://www.honda.ca/en/quebecregulatorynotice)

# INTRODUCTION

Congratulations on your selection of a Honda outboard motor. We are certain you will be pleased with your purchase of one of the finest outboard motors on the market.

We want to help you get the best results from your new outboard motor and to operate it safely. This manual contains information on how to do that; please read it carefully.

As you read this manual you will find information preceded by a **NOTICE** symbol. That information is intended to help you avoid damage to your outboard motor, other property, or the environment.

We suggest you read the warranty policy to fully understand its coverage and your responsibilities of ownership.

When your outboard motor needs scheduled maintenance, keep in mind that your Honda Marine outboard motor dealer is specially trained in servicing Honda outboard motors. Your Honda Marine outboard motor dealer is dedicated to your satisfaction and will be pleased to answer your questions and concerns.

For information regarding the optional equipment, refer to the owner's manual that came with it.

# INTRODUCTION

## A FEW WORDS ABOUT SAFETY

Your safety and the safety of others are very important. Using this outboard motor safely is an important responsibility.

To help you make informed decisions about safety, we have provided operating procedures and other information on labels and in this manual. This information alerts you to potential hazards that could hurt you or others.

Of course, it is not practical or possible to warn you about all the hazards associated with operating or maintaining an outboard motor. You must use your own good judgment.

You will find important safety information in a variety of forms, including:

- **Safety Labels** – on the outboard motor
- **Safety Messages** – preceded by a safety alert symbol  and one of three signal words, DANGER, WARNING, or CAUTION.

These signal words mean:

 **DANGER**

You WILL be KILLED or SERIOUSLY HURT if you don't follow instructions.

 **WARNING**

You CAN be KILLED or SERIOUSLY HURT if you don't follow instructions.

 **CAUTION**

You CAN be HURT if you don't follow instructions.

- **Safety Headings** – such as IMPORTANT SAFETY INFORMATION.
- **Safety Section** – such as OUTBOARD MOTOR SAFETY.
- **Instructions** – how to use this outboard motor correctly and safely.

This entire manual is filled with important safety information – please read it carefully.

## TRADEMARKS

NMEA2000<sup>®</sup> is a registered trademark of National Marine Electronics Association, Inc.

# CONTENTS

CONTENTS .....	3	START/STOP Switch .....	24
OUTBOARD MOTOR SAFETY .....	7	Emergency Stop Switch Clip and	
IMPORTANT SAFETY INFORMATION .....	7	Emergency Stop Switch .....	25
Operator Responsibility .....	7	Gearshift/Throttle Control Lever	
Refuel With Care .....	8	(Remote Control Lever) (Flush-Mount type) .....	26
Carbon Monoxide Hazard .....	8	Gearshift/Throttle Control Lever	
Be alert for underwater obstacles .....	9	(Remote Control Lever) (Top-Mount type) .....	27
SAFETY LABEL LOCATIONS .....	10	Select Switches .....	29
CE MARK/UKCA MARK LOCATION .....	11	COMMON CONTROLS .....	37
CONTROLS AND FEATURES .....	12	Power Trim/Tilt Switch .....	37
CONTROL AND FEATURE IDENTIFICATION CODES .....	12	Power Trim/Tilt Switch Panel .....	38
HOW TO DETERMINE WHICH DIRECTION THE		Power Tilt Switch .....	39
PROPELLER SHAFT ROTATES .....	13	Manual Relief Valve .....	39
COMPONENT AND CONTROL LOCATIONS .....	14	Tilt Lock Lever .....	40
Outboard Motor .....	14	Engine Cover Lock Levers .....	42
Remote Control Box (optional equipment) .....	17	NMEA Interface Coupler .....	42
Key Switch Panel (optional equipment) .....	18	Operating Hour Notification System .....	42
START/STOP Switch Panel (optional equipment) .....	19	INDICATORS .....	45
Power Trim/Tilt Switch Panel (optional equipment) .....	20	Alternator (ACG) Indicator .....	45
Emergency Stop Switch Panel (optional equipment) .....	20	Malfunction (PGM-FI) Indicator .....	45
Multi-function Display (optional equipment) .....	21	Low Oil Pressure Indicator .....	46
CONTROLS .....	22	Overheat Indicator .....	47
Ignition Switch (without START/STOP switch) .....	22	Cooling System Indicator .....	47
Power Switch (with START/STOP switch) .....	22	COOLING WATER INTAKE PORT .....	48
Honda Smart Key (optional equipment, For US,		OTHER FEATURES .....	48
Puerto Rico, US Virgin Islands and Canada) .....	23	Water Separator Buzzer .....	48

# CONTENTS

Rev Limiter .....	49	Maintenance Inspection .....	61
Anodes .....	49	OPERATION .....	62
Fuel Priming Bulb .....	50	SAFE OPERATING PRECAUTIONS .....	62
Battery Switch OFF Notification .....	50	BREAK-IN PROCEDURE .....	62
Power Reduction .....	50	FUEL PRIMING .....	63
INSTALLATION .....	51	INFREQUENT OR OCCASIONAL USE .....	64
TRANSOM HEIGHT .....	51	STARTING THE ENGINE .....	64
LOCATION .....	52	Active Mode .....	67
INSTALLATION HEIGHT .....	52	STOPPING THE ENGINE .....	68
OUTBOARD MOTOR INSTALLATION .....	52	Emergency Engine Stopping .....	68
OUTBOARD MOTOR ANGLE INSPECTION (cruising) .....	53	Normal Engine Stopping .....	69
BATTERY CONNECTIONS .....	54	GEARSHIFT AND THROTTLE OPERATION .....	71
REMOTE CONTROL INSTALLATION		Gearshift/Throttle Control Lever	
(optional equipment) .....	56	(Remote Control Lever) Friction .....	72
Remote Control Box .....	56	STEERING .....	74
Key Switch Panel .....	57	CRUISING .....	75
START/STOP Switch Panel .....	57	Engine Speed .....	75
Remote Control Box Location .....	58	Trim .....	75
PROPELLER SELECTION .....	58	Trim Support Mode .....	78
FUEL LINE CONNECTION .....	58	TROLLING CONTROL MODE .....	80
BEFORE OPERATION .....	59	ONE-LEVER MODE (Dual top-mount type) .....	81
ARE YOU READY TO GET UNDERWAY? .....	59	CRUISE CONTROL MODE .....	81
Knowledge .....	59	SHALLOW WATER OPERATION .....	83
Safety .....	59	MOORING, BEACHING, LAUNCHING .....	83
IS YOUR OUTBOARD MOTOR READY TO GO? .....	59	Moorage .....	85
Safety Inspection .....	60	Automatic Tilt Mode .....	87

# CONTENTS

Power Tilt Switch (Outboard Motor Panel) .....	88	Optional Spark Plug (Nickel) .....	115
Manual Relief Valve .....	89	REFUELING .....	116
MULTIPLE OUTBOARD MOTORS .....	89	FUEL RECOMMENDATIONS .....	117
TURNING WHEN MULTIPLE ENGINES ARE MOUNTED .....	90	GASOLINE CONTAINING ALCOHOL .....	118
ENGINE PROTECTION SYSTEM .....	93	FUEL FILTER WITH WATER SEPARATOR (LOW PRESSURE SIDE) INSPECTION AND REPLACEMENT .....	118
Engine Oil Pressure, Overheat, Water Contamination, PGM-FI and ACG Warning Systems .....	93	Inspection .....	119
Display type .....	94	Replacement .....	120
SERVICING YOUR OUTBOARD MOTOR .....	97	ANODE INSPECTION .....	122
THE IMPORTANCE OF MAINTENANCE .....	97	Water Screen Removal/Installation .....	122
MAINTENANCE SAFETY .....	98	PROPELLER REPLACEMENT .....	123
Safety Precautions .....	98	Removal .....	123
TOOL KIT and OWNER'S MANUAL .....	99	Installation .....	123
SPARE EMERGENCY STOP SWITCH CLIP (optional equipment) .....	100	BATTERY .....	125
MAINTENANCE SCHEDULE .....	100	Battery Cleaning .....	126
ENGINE COVER REMOVAL AND INSTALLATION .....	103	CLEANING AND FLUSHING .....	127
Removal .....	103	CLEANING AND FLUSHING .....	127
Installation .....	104	Cleaning .....	127
ENGINE OIL LEVEL CHECK .....	105	Flushing With a Water Hose (Garden Hose) (commmercially available) .....	128
ENGINE OIL CHANGE .....	108	STORAGE .....	130
ENGINE OIL RECOMMENDATIONS .....	109	FUEL .....	130
LUBRICATION POINTS .....	109	Storage Procedure .....	131
SPARK PLUG SERVICE .....	112	Adding a Fuel Stabilizer .....	132
Standard Spark Plug (Iridium) .....	112	Draining the Fuel System .....	132
		ENGINE OIL .....	133

# CONTENTS

BATTERY STORAGE .....	133	SUBMERGED OUTBOARD MOTOR .....	152
HOISTING THE OUTBOARD MOTOR .....	135	EMERGENCY GEAR SHIFTING .....	153
STORAGE PRECAUTIONS .....	135	TECHNICAL INFORMATION .....	154
REMOVAL FROM STORAGE .....	135	SERIAL NUMBER LOCATIONS .....	154
TRANSPORTING .....	136	BATTERY .....	155
FUEL LINE DISCONNECTION .....	136	Minimum Requirements .....	155
WITH OUTBOARD MOTOR INSTALLED ON BOAT .....	136	EMISSION CONTROL SYSTEM INFORMATION	
WITH OUTBOARD MOTOR REMOVED FROM BOAT .....	137	(For US, Puerto Rico, US Virgin Islands and Canada) .....	156
DISPOSAL .....	138	STAR LABEL	
TAKING CARE OF UNEXPECTED PROBLEMS .....	139	(For US, Puerto Rico, and US Virgin Islands) .....	159
ELECTRIC STARTER WILL NOT OPERATE .....	139	SPECIFICATIONS .....	161
ENGINE WILL NOT START .....	140	MAJOR Honda DISTRIBUTOR ADDRESSES (For Europe) .....	164
HARD STARTING OR STALLS AFTER STARTING .....	141	"UK DECLARATION OF CONFORMITY"	
ENGINE OVERHEATS .....	142	CONTENT OUTLINE (For Europe) .....	167
WARNING SYSTEM COMES ON .....	143	"EC DECLARATION OF CONFORMITY"	
FUSES .....	145	CONTENT OUTLINE (For Europe) .....	168
Electric Starter Will Not Operate .....	145	CONSUMER INFORMATION	
Battery Will Not Charge .....	145	(For US, Puerto Rico, US Virgin Islands and Canada) .....	173
Fuse Replacement .....	145	Dealer Locator Information .....	173
LOW OIL PRESSURE INDICATOR COMES ON AND		Honda Publications .....	173
ENGINE SPEED IS LIMITED .....	149	Customer Service Information .....	174
OVERHEAT INDICATOR COMES ON AND		Warranty Coverage .....	175
ENGINE SPEED IS LIMITED .....	150	CONSUMER INFORMATION	
WATER SEPARATOR BUZZER SOUNDS .....	152	(For US, Puerto Rico, and US Virgin Islands) .....	177
WHEN COLLIDING WITH AN		Emission Control System Warranty .....	177
UNDERWATER OBSTACLE .....	152	INDEX .....	183

# OUTBOARD MOTOR SAFETY

## IMPORTANT SAFETY INFORMATION

Honda BF300A/BF350A outboard motor is designed for use with boats that have a suitable manufacturer's power recommendation. Other uses can result in injury to the operator or damage to the outboard motor and other property.

Most injuries or property damage can be prevented if you follow all instructions in this manual and on the outboard motor. The most common hazards are discussed in this chapter, along with the best way to protect yourself and others.

## Operator Responsibility



- **Honda outboard motor is designed to give safe and dependable service if operated according to instructions. Read and understand the Owner's Manual before operating the outboard motor. Failure to do so could result in personal injury or equipment damage.**

- It is the operator's responsibility to provide the necessary safeguards to protect people and property. Know how to stop the engine quickly in case of emergency. Understand the use of all controls.
- Stop the engine immediately if anyone falls overboard, and do not run the engine while the boat is near anyone in the water.
- Always stop the engine if you must leave the controls for any reason.
- Attach the emergency stop switch lanyard securely to the operator.
- Always wear a PFD (Personal Flotation Device) while on the boat.

# OUTBOARD MOTOR SAFETY

---

- Familiarize yourself with all local laws and regulations relating to boating and the use of outboard motors.
- Be sure that anyone who operates the outboard motor receives proper instruction.
- Be sure the outboard motor is properly mounted on the boat.
- Do not remove the engine cover while the engine is running.

## Refuel With Care

- Gasoline is extremely flammable, and gasoline vapor can explode. Refuel outdoors, in a well-ventilated area, with the engine stopped. Never smoke near gasoline, and keep other flames and sparks away.
- Refuel carefully to avoid spilling fuel. Avoid overfilling the fuel tank.
- After refueling, tighten the filler cap securely. If any fuel is spilled, make sure the area is dry before starting the engine.

## Carbon Monoxide Hazard

Exhaust contains poisonous carbon monoxide, a colorless, odorless gas. Breathing carbon monoxide can cause loss of consciousness and may lead to death.

If you run the engine in an area that is confined, or even partly enclosed, the air you breathe could contain a dangerous amount of exhaust gas.

Never run your outboard inside a garage or other enclosure.

### **⚠ WARNING**

Running the engine of your outboard while in an enclosed or partially enclosed area can cause a rapid build-up of toxic carbon monoxide gas.

Breathing this colorless, odorless gas can quickly cause unconsciousness and lead to death.

Only run your outboard engine when it is located in a well-ventilated area outdoors.

### **Be alert for underwater obstacles**

In waters where there is a risk of collision with underwater obstacles or floating debris, reduce your speed and navigate with caution. If a collision occurs, the impact could lead to a serious accident or personal injury.

- Parts of the damaged outboard motor could come loose and be thrown into the boat.
- Passengers could be thrown out due to sudden deceleration.
- The outboard motor or hull could be damaged.

If you hit an underwater obstacle while underway, stop the engine immediately and inspect the outboard motor for any problems. (See page 152)

Continued use in a damaged condition may prevent safe cruise and lead to serious consequences.

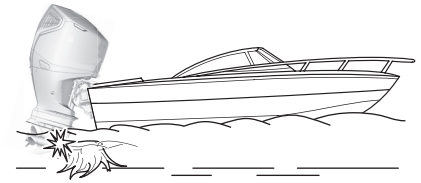

# OUTBOARD MOTOR SAFETY

---

## SAFETY LABEL LOCATIONS

These labels are in the locations shown.

They warn you of potential hazards that can cause serious injury.

Their meanings are explained on page 7.

The labels are considered permanent parts of your outboard motor.

Read the labels and safety notes and precautions described in this manual carefully.

If a label comes off or becomes hard to read, contact your Honda Marine outboard motor dealer for a replacement.

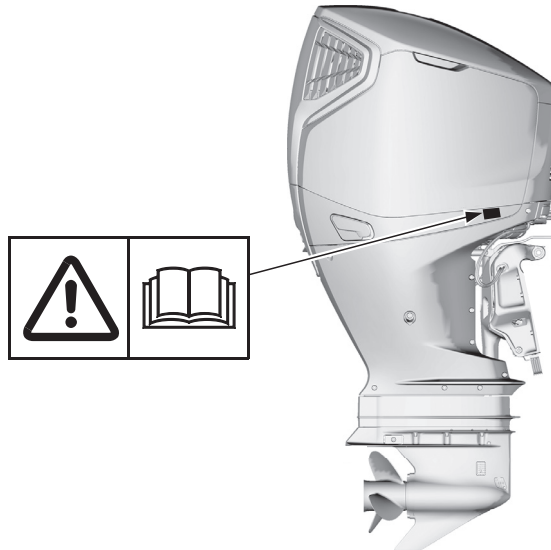

## CE MARK/UKCA MARK LOCATION

### CE MARK/UKCA MARK

[Example: BF350A]

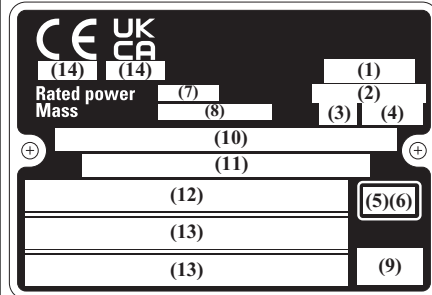

- (1) Model name
- (2) Engine family name
- (3) Minor model change code
- (4) Type name
- (5) Year code
- (6) Month code
- (7) Rated power
- (8) Dry mass (weight) (with propeller)
- (9) Country of manufacture
- (10) Frame serial number (Type and serial number of Declaration of Conformity)
- (11) CAN number
- (12) Manufacturer and address
- (13) Name and address of authorized representative
- (14) Identification number of the notified body



Year code	M	N	P	R	S	T	V	W	X	Y
Year of manufacture	2021	2022	2023	2024	2025	2026	2027	2028	2029	2030

Month code	A	B	C	D	E	F	G	H	J	K	L	M
Month of manufacture	1	2	3	4	5	6	7	8	9	10	11	12

Name and address of manufacturer and authorized representative and importer are written in the "Declaration of Conformity" CONTENT OUTLINE in this Owner's Manual.

# CONTROLS AND FEATURES

## CONTROL AND FEATURE IDENTIFICATION CODES

Model		BF300A				BF350A			
Type		XD□	UD□	XCD□	UCD□	XD□	UD□	XCD□	UCD□
Transom Height	638 mm (25.1 in)	•		•		•		•	
	765 mm (30.1 in)		•		•		•		•
Standard Rotating Propeller Shaft		•	•			•	•		
Counter-Rotating Propeller Shaft				•	•			•	•

Refer to this chart for an explanation of the Type Codes used in this manual to identify control and feature applications.

For the detailed equipment conditions of optional components, consult your Honda Marine outboard motor dealer.

### NOTE:

Note that the types of the outboard motor differ according to the countries where they are sold.

BF300A/BF350A is provided with the following types according to the shaft length and the rotating direction of the propeller shaft.

#### TYPE CODE (example)

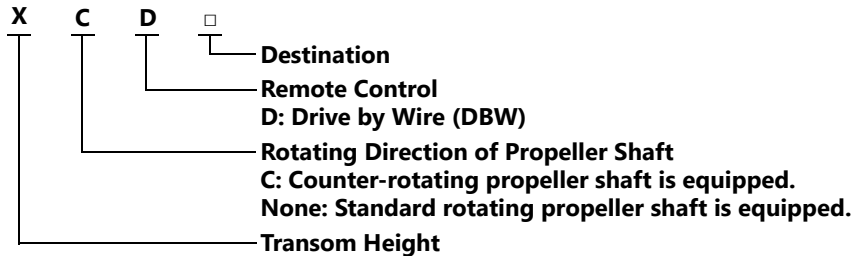

### HOW TO DETERMINE WHICH DIRECTION THE PROPELLER SHAFT ROTATES

The direction the propeller shaft rotates can be determined based on whether or not the propeller shaft holder has a groove.

- With groove: Counter-rotating
- Without groove: Standard rotating

**WITH GROOVE**

**GROOVE**

**WITHOUT GROOVE**

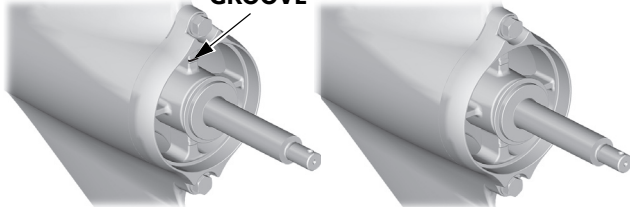

# CONTROLS AND FEATURES

---

## COMPONENT AND CONTROL LOCATIONS

### Outboard Motor

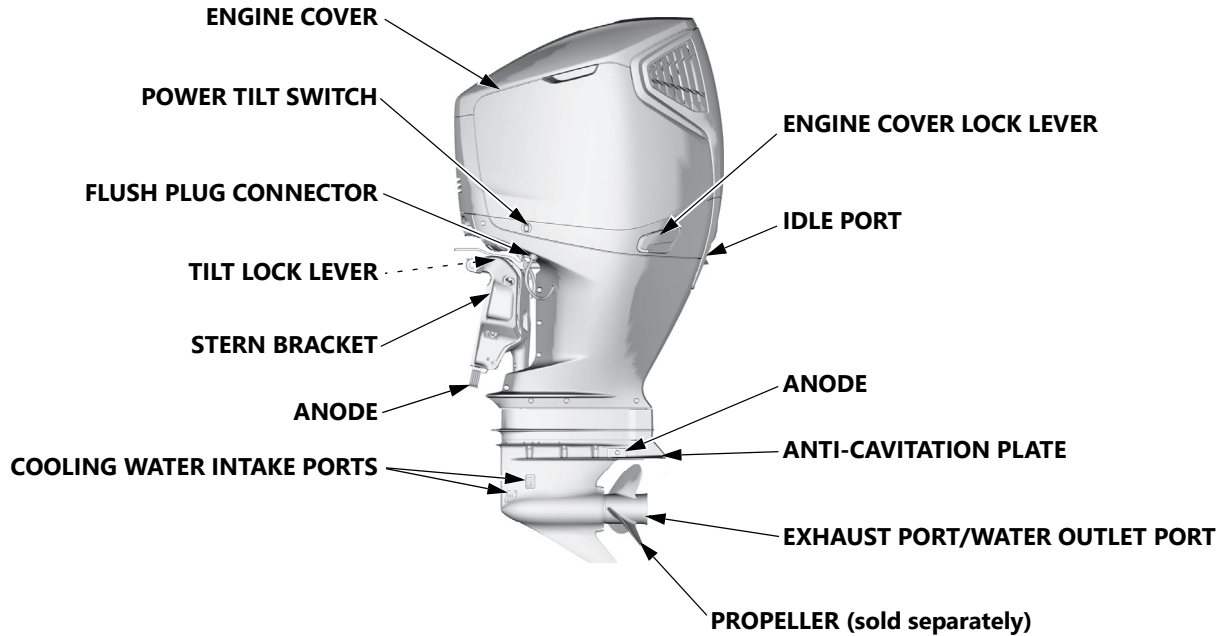

# CONTROLS AND FEATURES

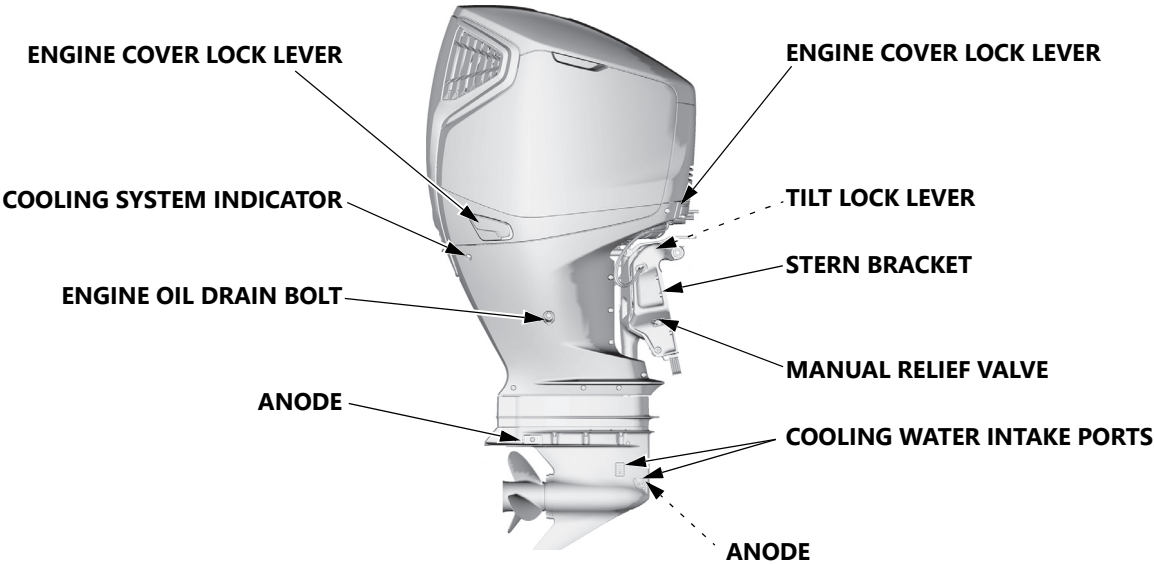

# CONTROLS AND FEATURES

---

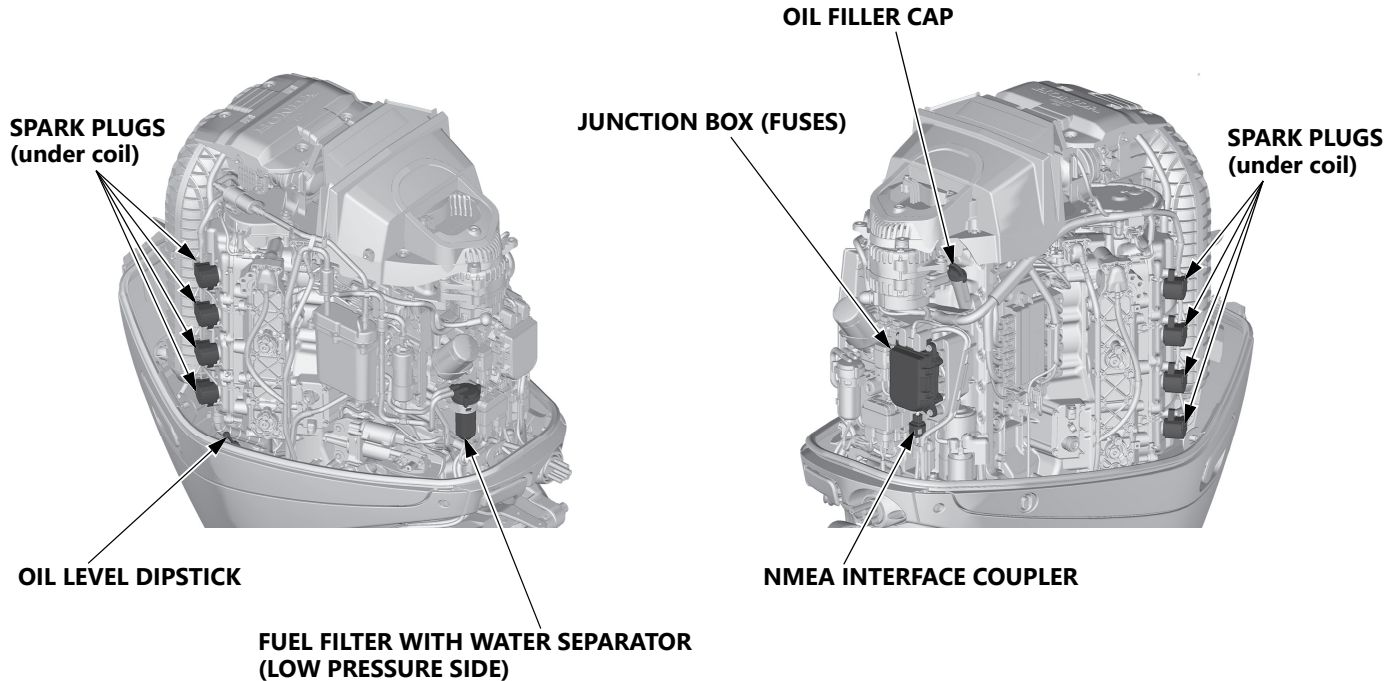

\* The figure above shows the engine with the front striker cover and the rear striker cover removed.

# CONTROLS AND FEATURES

## Remote Control Box (optional equipment)

### FLUSH-MOUNT REMOTE CONTROL

GEARSHIFT/THROTTLE CONTROL LEVER  
(REMOTE CONTROL LEVER)

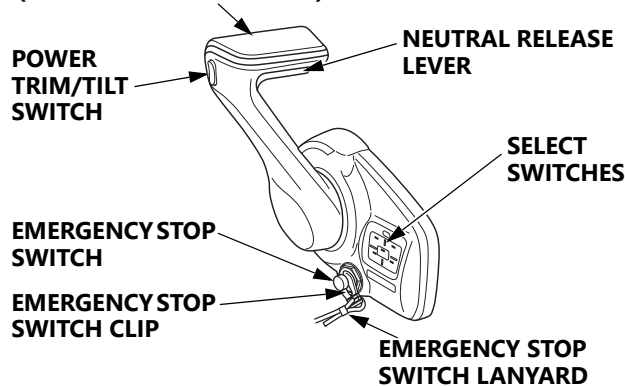

### SINGLE TOP-MOUNT REMOTE CONTROL

POWER TRIM/TILT SWITCH

GEARSHIFT/  
THROTTLE  
CONTROL LEVER  
(REMOTE  
CONTROL LEVER)

### DUAL TOP-MOUNT REMOTE CONTROL

POWER TRIM/TILT SWITCH

GEARSHIFT/  
THROTTLE  
CONTROL LEVERS  
(REMOTE  
CONTROL LEVERS)

NEUTRAL RELEASE LEVER

SELECT SWITCHES

SELECT SWITCHES

# CONTROLS AND FEATURES

## Key Switch Panel (optional equipment)

### Normal Key with START/STOP switch type

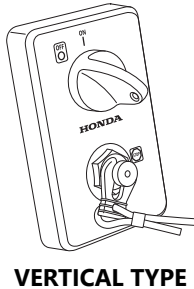
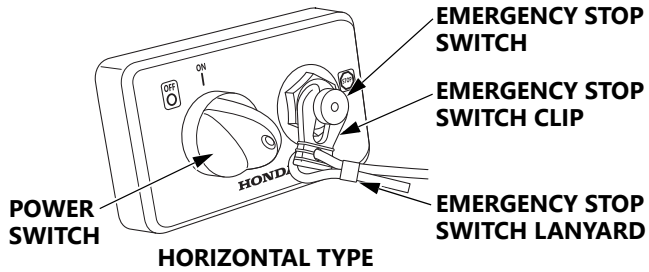

### Normal Key without START/STOP switch type

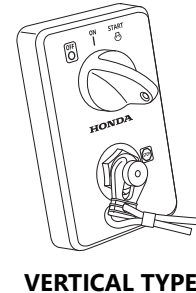
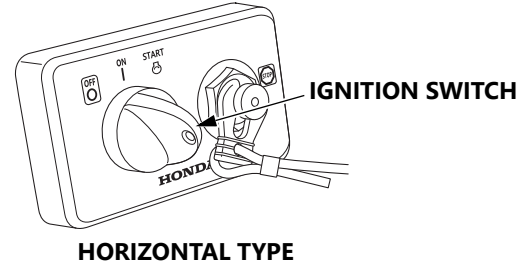

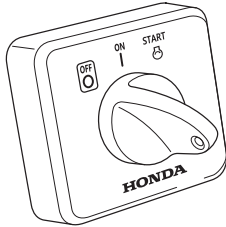

**FLUSH-MOUNT REMOTE CONTROL TYPE**

**NOTICE**

- For the switch panel without emergency stop switch type, use it along with the flush-mount type remote control box.

*Honda Smart Key type (For US, Puerto Rico, US Virgin Islands and Canada)*

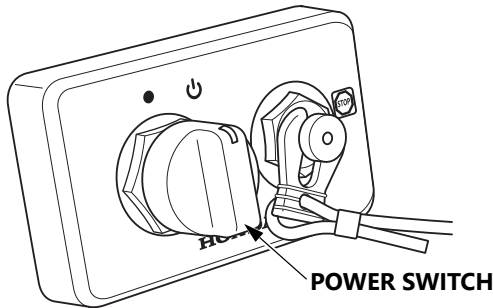

**POWER SWITCH**

## START/STOP Switch Panel (optional equipment)

### START/STOP SWITCH

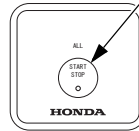

**ALL ENGINE START/STOP FOR MULTIPLE OUTBOARD MOTORS**

### START/STOP SWITCH

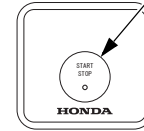

**SINGLE TYPE OUTBOARD MOTOR**

### INDICATORS

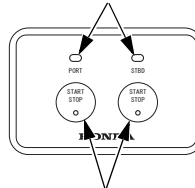

**START/STOP SWITCHES**

**DUAL TYPE (quad-type) OUTBOARD MOTOR**

### INDICATORS

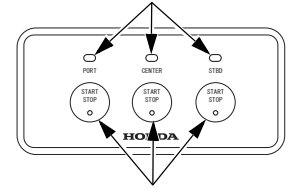

**START/STOP SWITCHES**

**TRIPLE TYPE OUTBOARD MOTOR**

**PORT:** Port side engine  
**CENTER:** Center engine  
**STBD:** Starboard side engine

# CONTROLS AND FEATURES

## Power Trim/Tilt Switch Panel (optional equipment)

### POWER TRIM/TILT SWITCHES

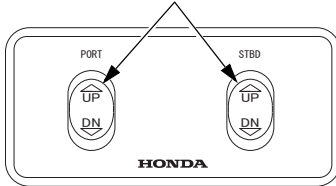

### DUAL TYPE OUTBOARD MOTOR

### POWER TRIM/TILT SWITCHES

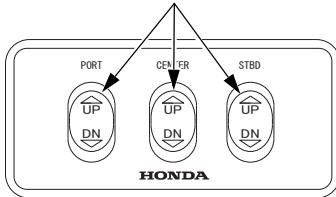

### TRIPLE TYPE OUTBOARD MOTOR

**PORT:** Port side engine  
**CENTER:** Center engine  
**STBD:** Starboard side engine

## Emergency Stop Switch Panel (optional equipment)

### EMERGENCY STOP SWITCH

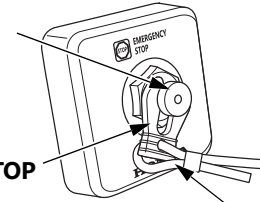

### EMERGENCY STOP SWITCH CLIP

### EMERGENCY STOP SWITCH LANYARD

## Multi-function Display (optional equipment)

Refer to the attached instruction manual about handling.

### ***Honda HD-5 (Display assy 4.3)***

- Some functions are not available on multi-function displays with a software version earlier than "Ver. 0.26". Consult with an authorized marine outboard motor dealer.

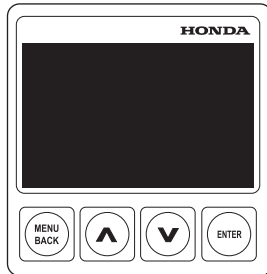

### ***Honda HD-7 (Display assy 7.0)***

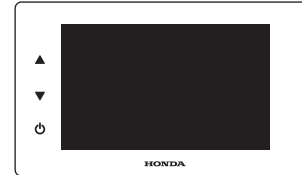

# CONTROLS AND FEATURES

## CONTROLS

### Ignition Switch (without START/STOP switch)

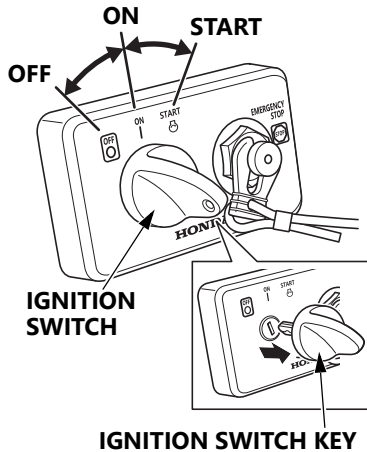

The ignition switch controls the ignition system and the starter motor.

Turning the ignition switch to the START position starts the engine. The ignition switch automatically returns to the ON position when released from the START position.

The engine will not start unless the gearshift/throttle control lever (remote control lever) is in the NEUTRAL position (P.65) and the emergency stop switch clip is in the emergency stop switch.

Turning the ignition switch to the OFF position stops the engine.

The ignition switch key can be removed and inserted when the ignition switch is in the OFF position. When the boat is not in use, remove the key.

#### NOTICE

- **Do not leave the ignition switch ON (key in ON position) when the engine is not running as the battery will discharge.**

### Power Switch (with START/STOP switch)

(Normal key type)

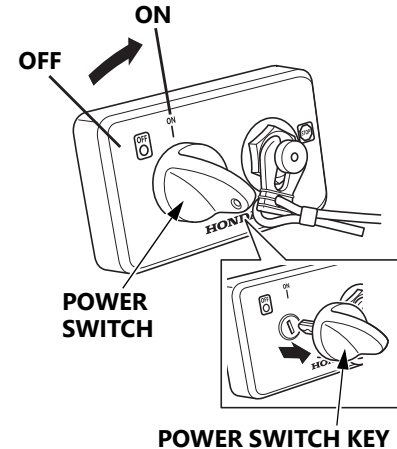

(Honda Smart Key type (For US, Puerto Rico, US Virgin Islands and Canada))

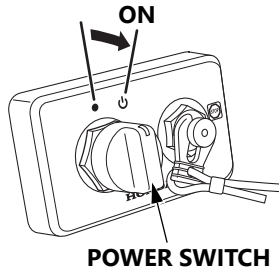

This remote control is equipped with a start/stop switch.

### Normal Key Type

- ON: This position allows the engine to start and run.
- OFF: This position stops the engine (Ignition OFF).

The power switch key can be removed and inserted when the power switch is in the OFF position. When the boat is not in use, remove the key.

### Honda Smart Key Type (For US, Puerto Rico, US Virgin Islands and Canada)

Turn the power switch clockwise and then release to turn the power ON. Turn and release the power switch again to turn the power OFF.

#### NOTICE

- **Turn the power off after the engine is stopped. If the power is not turned off after the engine is stopped, the battery will continue to drain until it is depleted.**

For the Honda Smart Key type, electric power cannot be supplied to the boat unless the Smart Key and remote control are properly paired (authenticated).

### Honda Smart Key (optional equipment, For US, Puerto Rico, US Virgin Islands and Canada)

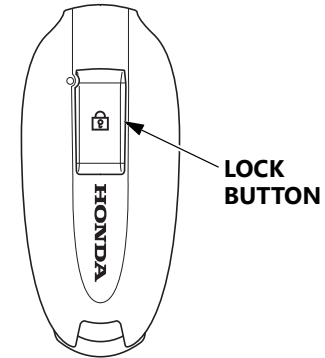

The Honda Smart Key has an immobilizer system. The immobilizer system helps to protect against boat theft. Refer to the Honda Smart Key Owner's Manual for complete information on the Smart Key system. The Honda Smart Key is available in certain areas.

# CONTROLS AND FEATURES

## START/STOP Switch

### START/STOP SWITCH

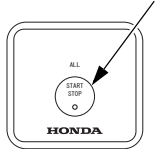

**ALL ENGINE START/STOP  
MULTIPLE OUTBOARD  
MOTORS**

### START/STOP SWITCH

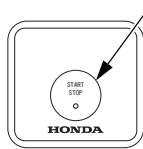

**SINGLE TYPE  
OUTBOARD MOTOR**

### INDICATORS

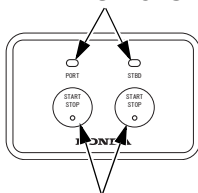

**START/STOP SWITCHES**

**DUAL TYPE (quad-type)  
OUTBOARD MOTOR**

### INDICATORS

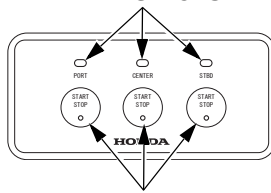

**START/STOP SWITCHES**

**TRIPLE TYPE  
OUTBOARD MOTOR**

To start the engine, be sure the power switch is in the ON position, and then press the start/stop switch button.

For boats with multiple outboard motors and equipped with the ALL ENGINE START/STOP switch, all motors can be started sequentially from the PORT side at the press of one button.

For boats equipped with multiple outboard motors and either the dual type or triple type start/stop switches, each outboard on the boat may be started individually and the corresponding indicator light will turn on after the engine has started.

The starter motor will not work unless the gearshift/throttle control lever (remote control lever) is in the NEUTRAL position, and the clip is in the emergency stop switch.

## Emergency Stop Switch Clip and Emergency Stop Switch

### EMERGENCY STOP SWITCH

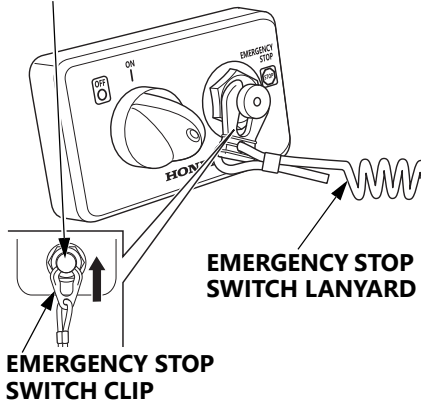

### EMERGENCY STOP SWITCH CLIP

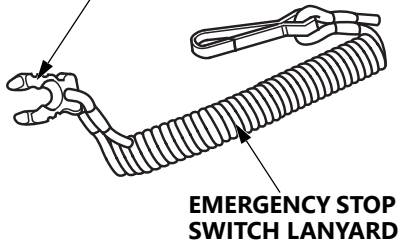

The emergency stop switch clip must be inserted in the emergency stop switch in order for the engine to start and run. The emergency stop switch lanyard must be attached securely to the operator or to the operator's PFD (Personal Flotation Device).

When used as described, the emergency stop switch clip and emergency stop switch lanyard system stops the engine if the operator falls away from the controls.

### **⚠ WARNING**

If the emergency stop switch lanyard is not set, the boat might run out of control when the operator, for example, falls overboard and is not able to operate the outboard motor.

For the sake of the operator's and the passenger's safety, be sure to set the emergency stop switch clip

located at one end of the emergency stop switch lanyard with the emergency stop switch. Attach the other end of the emergency stop switch lanyard securely to the operator. The emergency stop lanyard must be attached to the operator whenever the boat and engine is being operated.

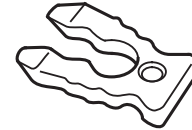

**SPARE SWITCH CLIP**

A spare switch clip should be stored near the controls in case the operator and primary switch clip falls overboard and a passenger needs to pilot the boat during an emergency situation.

# CONTROLS AND FEATURES

## Gearshift/Throttle Control Lever (Remote Control Lever) (Flush-Mount type)

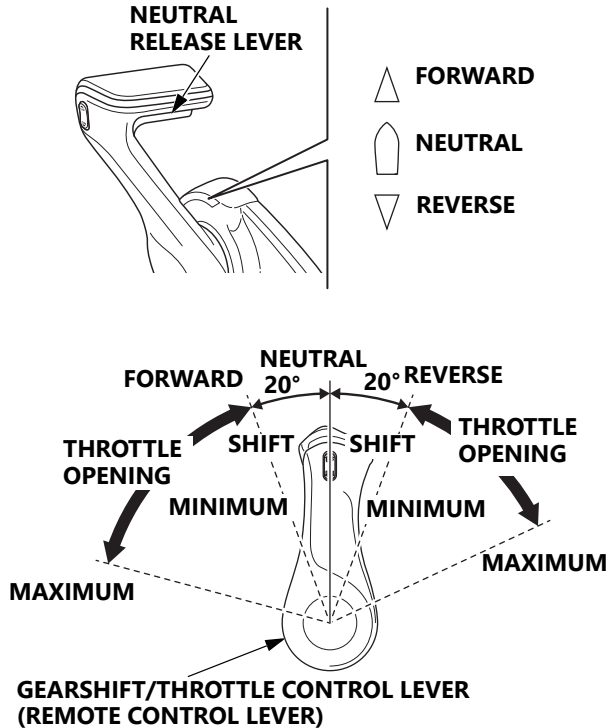

You can use the gearshift/throttle control lever (remote control lever) to shift gear into forward, reverse, or neutral, and to adjust the engine speed.

It is necessary to pull up the neutral release lever to operate the gearshift/throttle control lever (remote control lever).

### FORWARD:

Moving the lever to the FORWARD position (approximately 20° from the NEUTRAL position) engages the gear into forward. Moving the lever further from the FORWARD position will increase the throttle opening and the boat's forward speed.

### NEUTRAL:

Engine power is cut off from the propeller.

### REVERSE:

Moving the lever to the REVERSE position (approximately 20° from the NEUTRAL position) engages the gear into reverse. Moving the lever further from the REVERSE position will increase the throttle opening and the boat's reverse speed.

## Gearshift/Throttle Control Lever (Remote Control Lever) (Top-Mount type)

### SINGLE TYPE

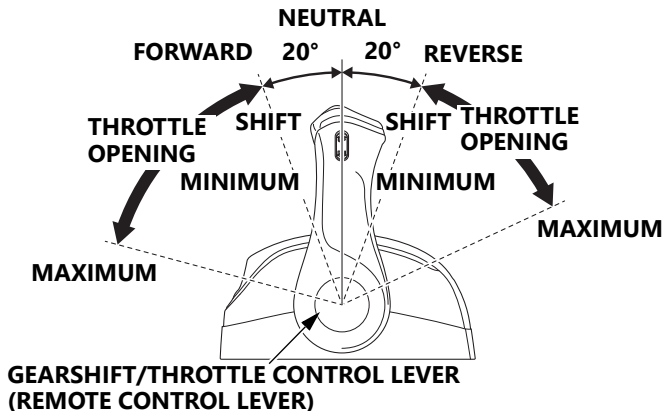
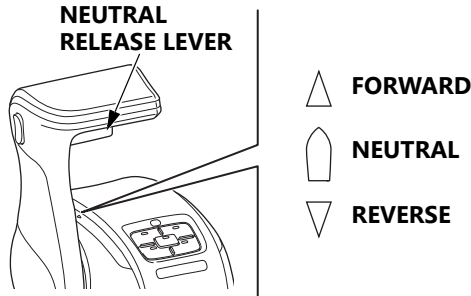

You can use the gearshift/throttle control lever (remote control lever) to shift gear into forward, reverse, or neutral, and to adjust the engine speed.

It is necessary to pull up the neutral release lever to operate the gearshift/throttle control lever (remote control lever).

#### FORWARD:

Moving the lever to the FORWARD position (approximately 20° from the NEUTRAL position) engages the gear into forward. Moving the lever further from the FORWARD position will increase the throttle opening and the boat's forward speed.

#### NEUTRAL:

Engine power is cut off from the propeller.

#### REVERSE:

Moving the lever to the REVERSE position (approximately 20° from the NEUTRAL position) engages the gear into reverse. Moving the lever further from the REVERSE position will increase the throttle opening and the boat's reverse speed.

# CONTROLS AND FEATURES

## DUAL TYPE

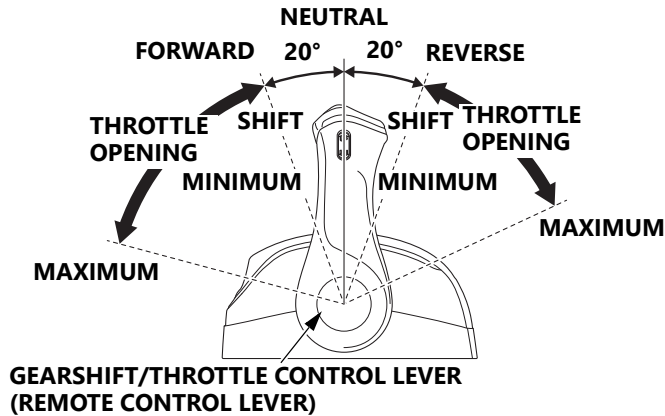
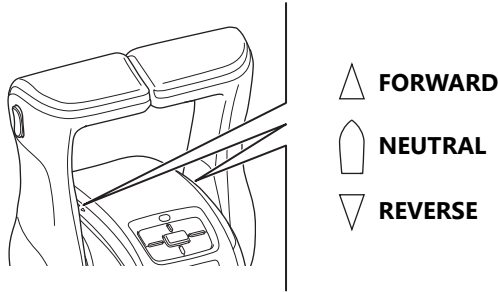

You can use the gearshift/throttle control lever (remote control lever) to shift gear into forward, reverse, or neutral, and to adjust the engine speed.

### FORWARD:

Moving the lever to the FORWARD position (approximately 20° from the NEUTRAL position) engages the gear into forward. Moving the lever further from the FORWARD position will increase the throttle opening and the boat's forward speed.

### NEUTRAL:

Engine power is cut off from the propeller.

### REVERSE:

Moving the lever to the REVERSE position (approximately 20° from the NEUTRAL position) engages the gear into reverse. Moving the lever further from the REVERSE position will increase the throttle opening and the boat's reverse speed.

# CONTROLS AND FEATURES

## Select Switches

FLUSH-MOUNT TYPE, SINGLE TOP-MOUNT TYPE

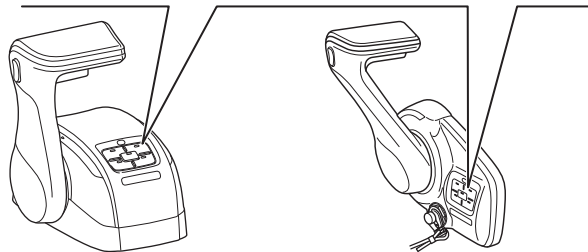
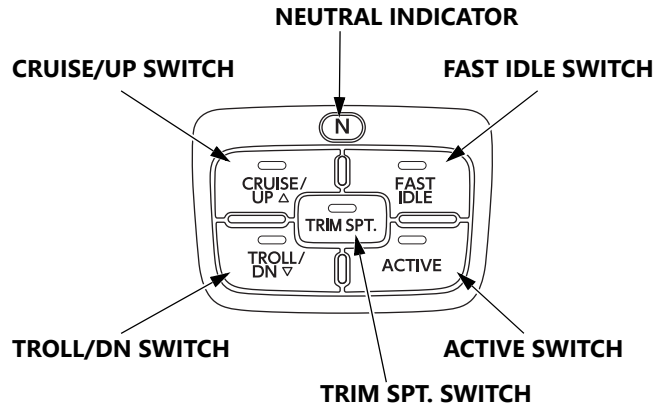

DUAL TOP-MOUNT TYPE

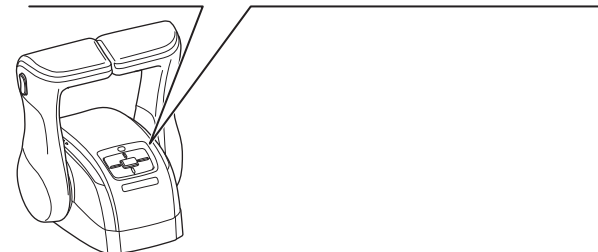
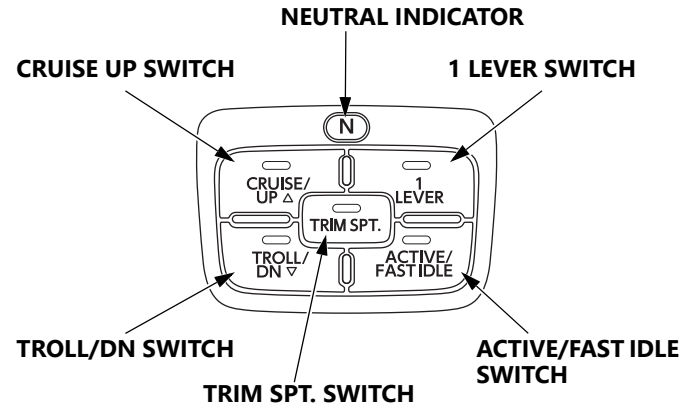

Select switches are used for operations in the fast idle mode, trolling control mode, one-lever mode, active mode, cruise control mode and trim support mode.

## CONTROLS AND FEATURES

### *Indicators on select switches*

<b>Indicator</b>	<b>On</b>	<b>Flashing</b>	<b>Off</b>
<b>NEUTRAL</b>	The gearshift/throttle control lever (remote control lever) is in the NEUTRAL position	Fast idle mode is on	The gearshift/throttle control lever (remote control lever) is in the FORWARD or REVERSE position
<b>CRUISE/UP</b>	Cruise control mode is on	Cruise control mode is paused	Cruise control mode is off
<b>TROLL/DN</b>	Trolling control mode is on	Trolling control mode is on And Fast idle mode is on	Trolling control mode is off
<b>TRIM SPT.</b>	Trim support mode is on	Trim support mode is paused	Trim support mode is off
<b>FAST IDLE</b>	-	Fast idle mode is on	Fast idle mode is off
<b>ACTIVE</b>	Active mode is on	-	Active mode is off
<b>1 LEVER</b>	One-lever mode is on	-	One-lever mode is off
<b>ACTIVE/FAST IDLE</b>	Active mode is on And Fast idle mode is off	Active mode is on And Fast idle mode is on	Active mode is off And Fast idle mode is off

### **ACTIVE Switch, ACTIVE/FAST IDLE Switch**

For multiple station type, use the ACTIVE switch or ACTIVE/FAST IDLE switch to change the operating remote control (active mode).

If you press the ACTIVE switch or ACTIVE/FAST IDLE switch on the remote control you want to operate the outboard motors when all gearshift/throttle control levers (remote control levers) are in the NEUTRAL position, the mode changes to active mode.

This allows the active remote control to control the engine. All other remote controls are switched off.

### **FAST IDLE Switch, ACTIVE/FAST IDLE Switch**

If you press the FAST IDLE switch or ACTIVE/FAST IDLE switch on the remote control in active mode when the gearshift/throttle control levers (remote control levers) are in the NEUTRAL position, the mode changes to the fast idle mode. You can adjust the engine speed by lowering the gearshift/throttle control lever (remote control lever) to the FORWARD or REVERSE side. In the case of dual top-mount remote control, the mode changes to the fast idle mode only for an engine whose gearshift/throttle control levers (remote control levers) are in the NEUTRAL position.

The BF350A and BF300A models use programmed fuel injection, so this mode will not be needed for starting. After the engine starts and if the outside temperature is below 5°C (41°F), the fast idle mode can be used to accelerate engine warm-up.

- You cannot turn on the fast idle mode without putting the gearshift/throttle control lever (remote control lever) in the NEUTRAL position.
- If remote controls are mounted at two places, changing of fast idle mode can be done only with the remote control that is in active mode (P.31).
- To release the fast idle mode, press the FAST IDLE switch or ACTIVE/FAST IDLE switch with all the gearshift/throttle control levers (remote control levers) put in the NEUTRAL position.
- When fast idle mode is released, a short buzz sounds twice.

# CONTROLS AND FEATURES

## FLUSH-MOUNT TYPE

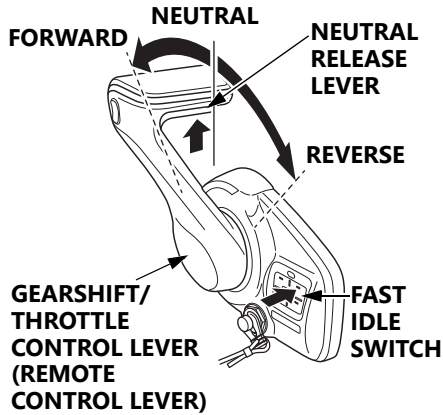

## SINGLE TOP-MOUNT TYPE

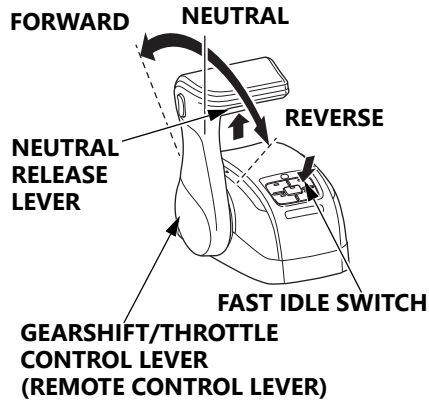

## DUAL TOP-MOUNT TYPE

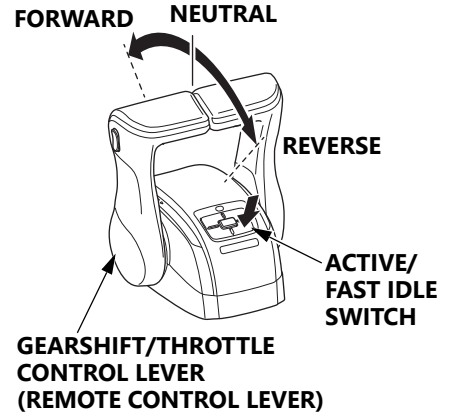

### **TROLL/DN Switch**

After the engine warms up, when the gearshift/throttle control levers (remote control levers) are tilted from the NEUTRAL position to the FORWARD or REVERSE side by about 20° and the TROLL/DN switch of the remote control is pressed, the mode changes to trolling control mode.

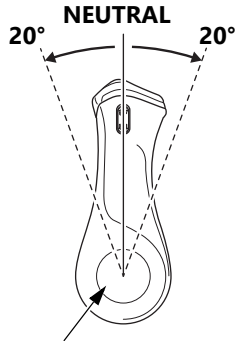

**GEARSHIFT/THROTTLE  
CONTROL LEVER  
(REMOTE CONTROL LEVER)**

The engine speed can be adjusted with the CRUISE/UP switch and TROLL/DN switch when in trolling control mode.

After the mode changes to the trolling mode, the engine speed is 650 min<sup>-1</sup> (rpm).

### **Engine speed adjusting range:**

650 min<sup>-1</sup> (rpm) to 1,000 min<sup>-1</sup> (rpm) (in steps of 50 min<sup>-1</sup> (rpm))

When in trolling control mode, trolling control mode is not released even if you put the gearshift/throttle control lever (remote control lever) in the NEUTRAL position. By shifting from NEUTRAL to FORWARD or REVERSE again, the boat will cruise at the set engine speed.

### **⚠ CAUTION**

While in trolling control mode, check whether the mode indicator is ON/OFF before shifting the gearshift/throttle control lever (remote control lever) from the NEUTRAL position to the FORWARD or REVERSE position. Operating the gearshift/throttle control lever (remote control lever) while trolling control mode is ON creates a risk of collision or injury due to an unexpected sudden start, which is caused by the engine starting to cruise at the speed set for trolling control mode, not by how far the throttle is opened.

## CONTROLS AND FEATURES

---

- If the engine is not finished warming up, it cannot go into trolling mode. So, warm up the engine (P.65).
- If remote controls are mounted at two places, the changing of trolling control mode can be done only with the remote control that is in active mode (P.66).
- You can force the release of trolling control mode by using the gearshift/throttle control lever (remote control lever) to increase the engine speed to  $3,000 \text{ min}^{-1}$  (rpm) or higher.
- To release the trolling control mode, press and hold the TROLL/DN switch.
- When the trolling control mode is released, a short buzz sounds twice.

### ***1 LEVER Switch (For dual top-mount type)***

Shifting gear and the engine speed adjustment of all the outboard motors can be performed with one gearshift/throttle control lever (remote control lever) when in one-lever mode.

If you press the 1 LEVER switch on the remote control in active mode when all gearshift/throttle control levers (remote control levers) are in the NEUTRAL position, the mode changes to one-lever mode.

- If remote controls are mounted at two places, the changing of one-lever mode can be done only with the remote control that is in active mode (P.31).

- To release one-lever mode, press and hold the 1 LEVER switch with the gearshift/throttle control lever (remote control lever) in the NEUTRAL position.
- When one-lever mode is released, a short buzz sounds twice.
- To use one-lever mode the next time you are boating, turn the ignition switch or the power switch off while in one-lever mode so that the next time you go boating the one-lever mode will be on.

### **CRUISE/UP Switch**

If you press the CRUISE/UP switch during cruising with all the gearshift/throttle control levers (remote control levers) in the FORWARD position, the mode changes to the cruise control mode, which lets the boat cruise at a constant engine speed or velocity.

- Velocity can only be adjusted in cruise control mode when equipped with GPS.

#### **NOTICE**

- **Operations may be inconsistent, depending on the GPS that you are using. Consult your dealer for more information about GPS.**

In the cruise control mode, pressing the CRUISE/UP switch increases the engine speed or velocity and pressing the TROLL/DN switch decreases it.

### **Engine speed adjusting range:**

Engine speed at mode change  $\pm 500 \text{ min}^{-1}$  (rpm) (in steps of  $50 \text{ min}^{-1}$  (rpm))

### **Velocity adjusting range:**

- Velocity at mode change  $\pm 10 \text{ km/h}$  (in steps of  $1.0 \text{ km/h}$ )
- Velocity at mode change  $\pm 5 \text{ miles/h}$  (in steps of  $0.5 \text{ miles/h}$ )
- Velocity at mode change  $\pm 5 \text{ knots}$  (in steps of  $0.5 \text{ knots}$ )

- To select whether to adjust the engine speed or velocity in the cruise control mode, use a Honda multi-function display.
- If remote controls are mounted at two places, the changing of cruise control mode can be done only with the remote control that is in active mode (P.31).
- The mode does not change to the cruise control mode in the following cases.
  - GPS has not been started (Velocity adjustment is selected in the multi-function display)
  - The trolling control mode is on
  - In the case of multiple outboard engines, when even one of the outboard engines has stopped

## CONTROLS AND FEATURES

---

- The cruise control mode is stopped temporarily if you make a turn or turn the boat continuously.
  - To release the cruise control mode, press and hold the CRUISE/UP switch.
  - When the cruise control mode is released, a short buzz sounds twice.
  - The cruise control mode is released forcibly in the following cases.
    - GPS error or disconnection (Velocity adjustment is selected in the multi-function display)
    - Engine stops or engine is abnormal (overheating, low oil pressure, etc.)
    - If the engine RPM or speed is unstable
  - Operate the gearshift/throttle control lever (remote control lever) is moved beyond as set amount or shift to the opposite of the set amount.\*
- \* Operation of a set amount
- If you put the engine speed at  $3,000 \text{ min}^{-1}$  (rpm), switch to cruise control mode, and use the CRUISE/UP switch to adjust to  $3,500 \text{ min}^{-1}$  (rpm)
    - The mode is forcibly released by operating the gearshift/throttle control lever (remote control lever) to the FORWARD side to increase the engine speed to  $3,500 \text{ min}^{-1}$  (rpm) or more.
    - The mode is forcibly released immediately if the gearshift/throttle control lever (remote control lever) is operated to the REVERSE side.
  - If you put the engine speed at  $3,000 \text{ min}^{-1}$  (rpm), switch to cruise control mode, and use the TROLL/DN switch to adjust to  $2,500 \text{ min}^{-1}$  (rpm)
    - When the gearshift/throttle control lever (remote control lever) is operated to the REVERSE side and the engine speed exceeds  $2,500 \text{ min}^{-1}$  (rpm), the mode is forcibly released.
    - The mode is forcibly released immediately if the gearshift/throttle control lever (remote control lever) is operated to the FORWARD side.
  - The mode is forcibly released immediately by putting the gearshift/throttle control lever (remote control lever) in NEUTRAL.

## **TRIM SPT. Switch**

Pressing the TRIM SPT. switch changes the mode to the trim support mode, which automatically does trim operations according to the speed or engine RPM. The conditions that control the trim operation (engine RPM and speed) and the trim angle pattern are set in the multi-function display.

For information about how to use the power trim/tilt switch, see page 37.

- If remote controls are mounted at two places, the changing of trim support mode can be done only with the remote control that is in active mode (P.31).
- To release the trim support mode, press the TRIM SPT. switch.
- When trim support mode is released, a short buzz sounds twice.

## **COMMON CONTROLS**

### **Power Trim/Tilt Switch**

(Flush-mount type)

**GEARSHIFT/THROTTLE CONTROL LEVER (REMOTE CONTROL LEVER)**

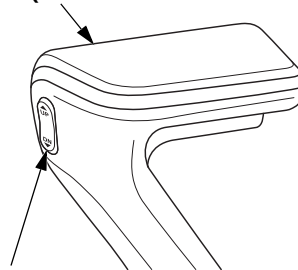

**POWER TRIM/TILT SWITCH**

(Top-mount type)  
**SINGLE TYPE**

**GEARSHIFT/THROTTLE CONTROL LEVER (REMOTE CONTROL LEVER)**

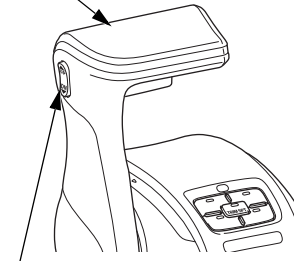

**POWER TRIM/TILT SWITCH**

**DUAL TYPE**

**GEARSHIFT/THROTTLE CONTROL LEVERS (REMOTE CONTROL LEVERS)**

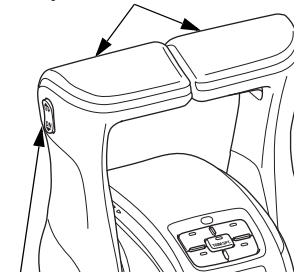

**POWER TRIM/TILT SWITCH**

## CONTROLS AND FEATURES

The power trim/tilt switch is located on the gearshift/throttle control lever (remote control lever). It is a rocker switch with UP and DN (down) positions for changing the angle of the outboard motor.

You can use the power trim/tilt switch anytime whether the boat is underway, stopped, or the ignition switch is in the OFF position.

Trim the outboard motor to obtain the best performance and stability. For details about the power trim, see page 75.

Tilt the outboard motor for shallow water operation, beaching, launching, or mooring. For details about the power tilt, see page 83.

For multiple outboard motors, tilt them up at the same time.

### Power Trim/Tilt Switch Panel

#### POWER TRIM/TILT SWITCH PANEL

##### DUAL TYPE

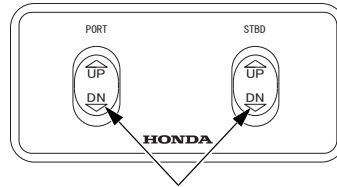

POWER TRIM/TILT SWITCHES

##### TRIPLE TYPE

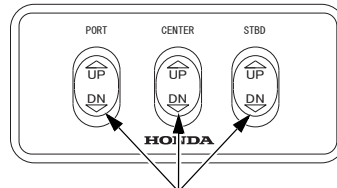

POWER TRIM/TILT SWITCHES

For multiple outboard motors, the trim/tilt angle of all outboard motors is adjusted at the same time by using the power trim/tilt switch on the gearshift/throttle control lever (remote control lever) and the trim/tilt angle of each outboard motor is adjusted by using each power trim/tilt switch on the panel.

### Power Tilt Switch

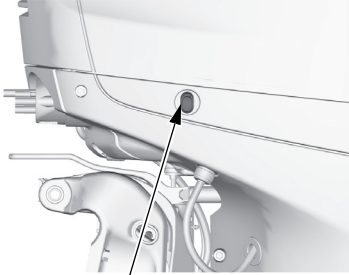

**POWER TILT SWITCH**

The power tilt switch is located on the engine pan. It is a rocker switch with UP and DN (down) positions for changing the angle of the outboard motor.

The power tilt switch operates without turning the ignition switch ON.

This switch is used, while the engine is stopped, to raise the outboard motor for mooring, trailering, or maintenance.

### ⚠ CAUTION

Do not operate the power tilt switch on the outboard motor cover while cruising. You can lose control of your balance, fall, and be injured by the moving outboard, propeller, or boat. Always use the gearshift/throttle control lever (remote control lever) or the power trim/tilt switch on the switch panel while under way.

### Manual Relief Valve

#### MANUAL RELIEF VALVE

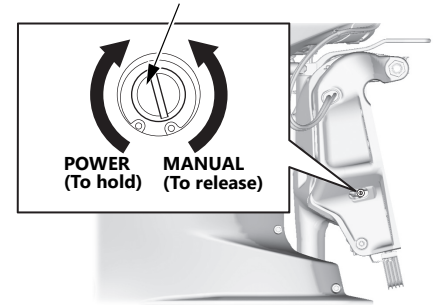

The outboard motor can be tilted manually after opening the manual relief valve. This allows the outboard motor to be tilted up or down when no battery is connected.

## CONTROLS AND FEATURES

### **⚠ DANGER**

Check that nobody is under the outboard motor before opening the manual relief valve. If the manual relief valve is loosened (turned counterclockwise) when the outboard motor is tilted up, the outboard motor will suddenly tilt down.

### **⚠ CAUTION**

The manual relief valve must be tightened securely before operating the outboard motor otherwise the outboard motor could tilt when operating in reverse.

### **NOTICE**

- **If there is not enough clearance to the ground, opening the manual relief valve may cause the outboard motor to contact the ground and be damaged.**

### **Tilt Lock Lever**



**TILT LOCK LEVER (each side)**

The tilt lock levers are used to support the outboard motor in the fully raised position (P.83).

When the boat is to be moored for a long time, tilt the outboard motor up as far as it will go. Then move the tilt lock levers to the LOCK position, and gently lower the outboard motor until the lever contacts the stern bracket.

### NOTICE

- Before tilting it up, leave the outboard motor in the running position for one minute after stopping the engine to drain the water from inside the engine.
- Be careful that while the outboard motor is tilted up that it does not collide with the pier or other boats.

When tilted up to 65°

TILT LOCK LEVER (each side)

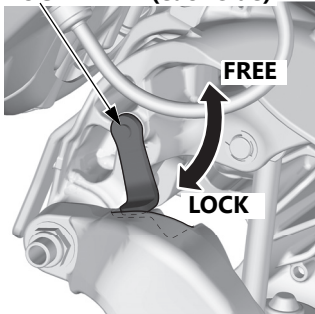

When tilted up to 55°

TILT LOCK LEVER (each side)

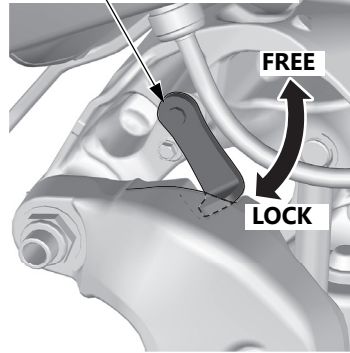

The tilt lock levers of the BF300A/BF350A can lock the outboard motor at two tilt angles of 65° or 55°.

If it is not possible to tilt up to 65°, due to the hull, lock the outboard motor at 55°.

### ⚠ CAUTION

If you do not secure the outboard motor with the tilt lock levers after you tilt up the outboard motor by 55° or 65° or more, then the hydraulic pressure of the power trim/tilt may drop and cause the outboard motor to tilt down.

# CONTROLS AND FEATURES

## Engine Cover Lock Levers

Front

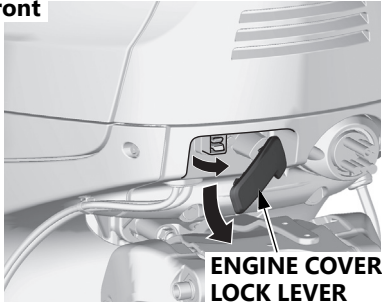

Side

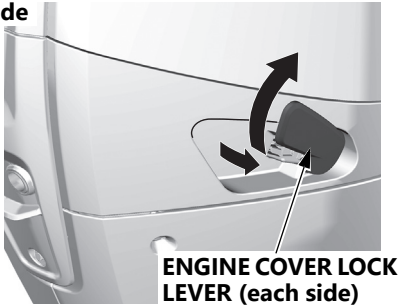

The engine cover lock levers fasten the engine cover to the outboard motor.

Refer to ENGINE COVER REMOVAL AND INSTALLATION on 103.

## NMEA Interface Coupler

The NMEA2000<sup>®</sup> interface coupler connects the outboard motor to the boat's NMEA2000<sup>®</sup> network through an interface cable and transmits information such as engine information and warnings to the control panel and gauges. Contact your dealer for more information.

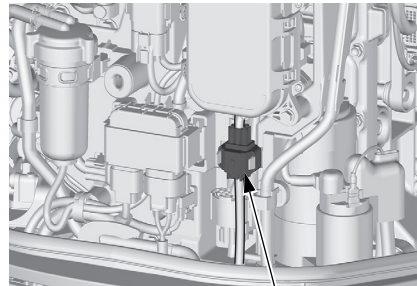

**NMEA INTERFACE COUPLER**

## Operating Hour Notification System

This outboard motor engine counts the number of operating hours since the last periodic maintenance. When the next periodic maintenance is due, the engine notifies the NMEA2000<sup>®</sup> network, and a maintenance indication is displayed on an NMEA2000<sup>®</sup>-compatible device.

After periodic maintenance is performed, reset the hour counter by:

1. Turn ON the power switch or ignition switch. (The buzzer will sound twice.)
2. Insert and remove the emergency stop switch clip five times within 20 seconds.
  - When reset, the buzzer will sound once.

### NOTICE

- **The operating hours can be reset when all of the following conditions are met.**
  - The engine is stopped
  - The gearshift is in neutral
  - The gearshift/throttle control lever (remote control lever) is in the NEUTRAL position
  - Buzzer is not sounding
  - Automatic tilt is not operating
- **If the operating hours are not reset, contact the authorized marine outboard motor dealer.**

Periodic maintenance is required when either the operating hours or the time since last maintenance reaches the prescribed limit. Therefore, periodic maintenance may be required based on the number of months since the last maintenance before the alert based on engine operating hours appeared (see MAINTENANCE SCHEDULE on page 100). Reset the hour counter whenever maintenance is performed, whether based on the time interval or the number of operating hours.

### Operating hour notification timing

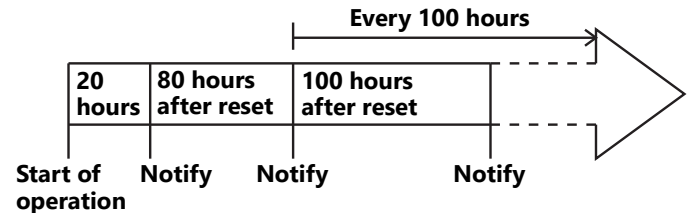

## CONTROLS AND FEATURES

---

### ***Periodic maintenance display***

- Notification about periodic maintenance is displayed on the multi-function display when the power switch or the ignition switch is turned on.
- The notification for periodic maintenance remains displayed after the engine is started.
- The display disappears when the gearshift/throttle control lever (remote control lever) is put in the FORWARD or REVERSE position.

### NMEA2000® -compatible display:

- Follow the instructions on the display.
- If the display allows selection of notification to be preset, select "Notify" (or equivalent).

- Turn on the power supply to the display before turning on the ignition switch of the outboard motor.
- The indication may differ, depending on the type of display.

When "Periodic Maintenance" is indicated:

1. Have the periodic maintenance performed without delay after returning to port.
2. Reset the hour counter. If not reset, the maintenance indication will remain in the display, and the hour count until the next maintenance will be in error.

When the periodic maintenance is conducted before "Periodic Maintenance" is indicated, reset the hour counter. If not reset, the hour count until the next maintenance will be in error.

## INDICATORS

Check the indicators displayed on the multi-function display. For information about NMEA2000<sup>®</sup> - compatible device displays, refer to the display device's manual.

### Alternator (ACG) Indicator

#### *Multi-function Display*

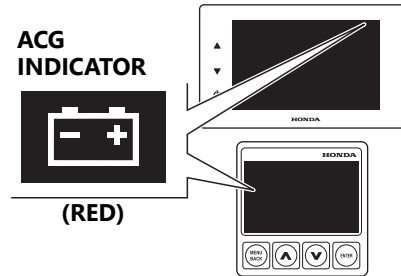

The ACG indicator turns on and the buzzer sounds in one-second intervals when the charging system is faulty.

### Malfunction (PGM-FI) Indicator

#### *Multi-function Display*

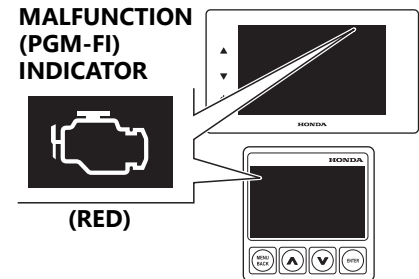

When the engine control system detects an engine control system malfunction, the malfunction (PGM-FI) indicator turns on.

## CONTROLS AND FEATURES

When the malfunction (PGM-FI) indicator turns on, the buzzer sounds continuously with an intermittent long sound.

- If the malfunction (PGM-FI) indicator lights and the buzzer does not stop sounding: Return to port immediately without continuing your voyage. There is a risk of shift operation failure (see page 153), alert detection failure, or engine start failure.
- If the malfunction (PGM-FI) indicator lights and the buzzer sounds for only 10 seconds: Return to port as soon as possible because engine speed control and other functions will be limited.

### Low Oil Pressure Indicator

#### *Multi-function Display*

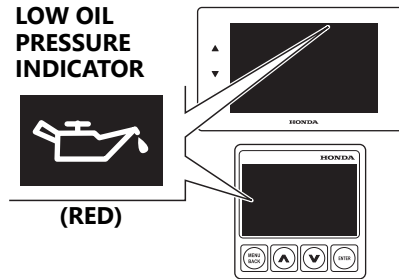

If oil pressure becomes low, the indicator comes on, and the engine protection system limit engine speed. Refer to TAKING CARE OF UNEXPECTED PROBLEMS, on P.139.

All models are equipped with a buzzer that sounds continuously when the low oil pressure indicator comes on.

Low oil pressure indicates that the engine oil level is low or that there is a problem with the engine lubrication system.

### Overheat Indicator

#### Multi-function Display

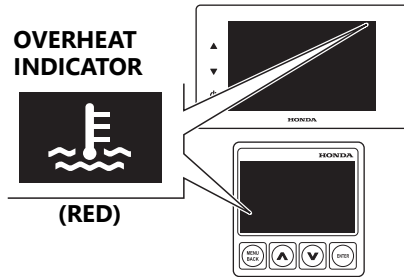

When the alert triggers, the overheat indicator comes on and the buzzer sounds a steady tone as the engine speed is reduced to  $1,800 \text{ min}^{-1}$  (rpm). If the condition persists for another 20 seconds, the engine shuts off. Refer to **TAKING CARE OF UNEXPECTED PROBLEMS**, on P.139.

All models are equipped with a buzzer that sounds continuously when the red overheat indicator light comes on.

Engine overheating may be the result of clogged water intakes.

### Cooling System Indicator

#### COOLING SYSTEM INDICATOR

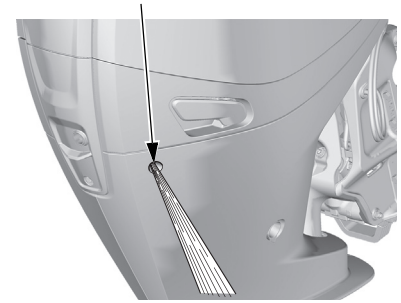

Water should flow from the cooling system indicator while the engine is running. This shows that water is circulating through the cooling system.

If water stops flowing while the engine is running, it indicates a cooling system problem, such as clogged water intakes, which will cause engine overheating.

## CONTROLS AND FEATURES

The cooling system indicator discharge port can also become plugged. If this happens, shut off the engine immediately and inspect the intake screens.

### COOLING WATER INTAKE PORT

COOLING WATER INTAKE PORT  
(each side)

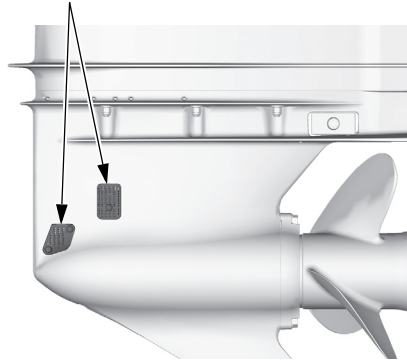

The engine cooling water is drawn into the engine through these ports.

### OTHER FEATURES

#### Water Separator Buzzer

WATER SEPARATOR

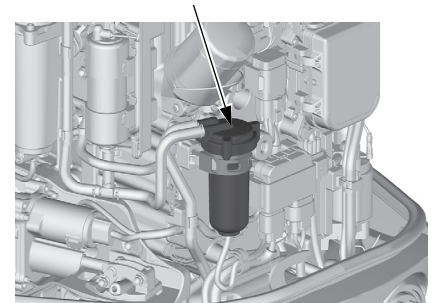

The water separator buzzer sounds a rapid, repeating signal when water has accumulated in the water separator.

To check the water separator, you need to remove the front striker guide cover. (P.119)

### Rev Limiter

The engine is equipped with a rev limiter to prevent the possibility of mechanical damage from excessive engine speed.

The rev limiter may be activated during operation, limiting engine speed, if the outboard motor is trimmed or tilted up excessively, or when propeller ventilation occurs during a sharp turn.

If the rev limiter is activated, check the trim angle of the outboard motor.

Check to see if the correct propeller is installed.

### Anodes

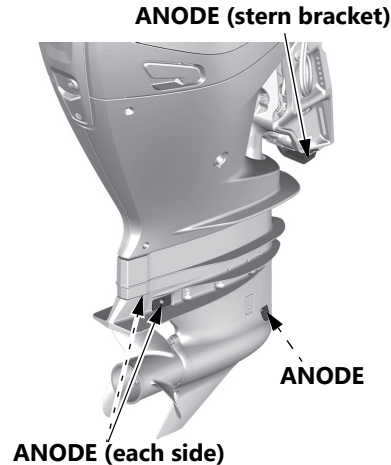

The anodes are made of a sacrificial material that helps to protect the outboard motor from corrosion.

There are three anodes on the gear case, one on the stern bracket (P.122).

Additional anodes are located inside the engine and should be serviced by an authorized Honda Marine outboard motor dealer according to the MAINTENANCE SCHEDULE (P.100).

#### NOTICE

- **Painting or coating the anodes will defeat their purpose and will lead to rust and corrosion damage to the outboard motor. The anodes must be exposed to the water in order to protect the outboard motor.**

# CONTROLS AND FEATURES

## Fuel Priming Bulb

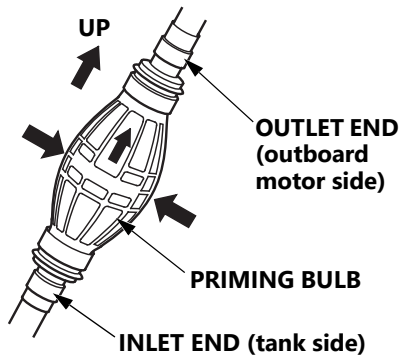

A priming bulb is built into the fuel hose that connects the fuel tank to the outboard motor.

Before starting the engine, hold the priming bulb up in the direction of the arrow; then squeeze the priming bulb until it feels firm. This will ensure that fuel is supplied to the engine (P.63).

## Battery Switch OFF Notification

This function alerts the operator that the boat's battery switch is OFF and must be turned to the ON position. If the battery switch is OFF, a buzzer will sound three times during the following situations.

- When starting the engine
- When using the power trim/tilt switch
- When turning the battery switch OFF while the ignition switch or power switch is ON

## Power Reduction

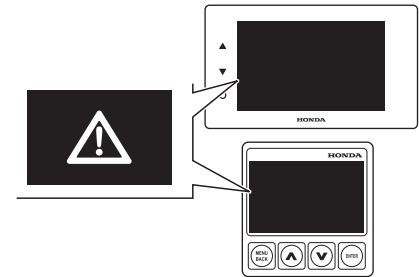

This outboard motor is equipped with the power reduction system which activates when the outboard motor has a serious problem.

The power reduction system decreases the engine speed to protect the engine until the malfunction is corrected.

When one of the two systems of the remote control sensor is faulty, the power reduction system does not decrease the engine speed.

# INSTALLATION

## NOTICE

- **Improperly installed outboard motor can result in the outboard motor dropping into the water, boat not being able to cruise straight ahead, engine speed not increasing, and extreme fuel consumption.**

We recommend that the outboard motor be installed by an authorized Honda Marine outboard motor dealer. Consult the authorized Honda Marine outboard motor dealer in your area for the Y-OP (User Optional Parts)/equipment installation and operation.

Applicable Boat  
Select a boat suitable for the engine power and weight.

Engine power:  
BF300A: 220.7 kW (300 PS) /  
223.7 kW (300 HP)\*  
BF350A: 257.4 kW (350 PS) /  
260.9 kW (350 HP)\*  
\* US certification value

Power recommendation is indicated on most of the boats.

## ⚠ WARNING

Do not exceed the boat manufacturer's power recommendation. Damage and injury may result.

## TRANSOM HEIGHT

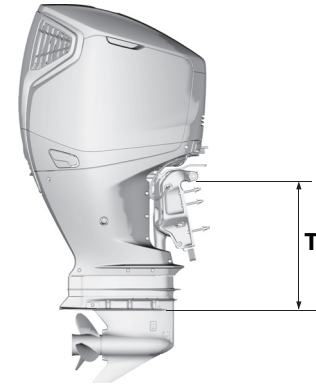

Type:	T (Outboard Motor Transom Height) <when transom angle is 12°>
X:	638 mm (25.1 in)
U:	765 mm (30.1 in)

Select an outboard motor which is correct for the boat transom height of your boat.

# INSTALLATION

## LOCATION

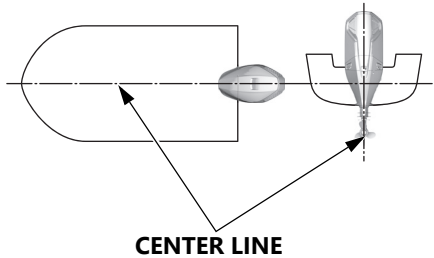

Install the outboard motor at the stern, at the center line of the boat.

## INSTALLATION HEIGHT

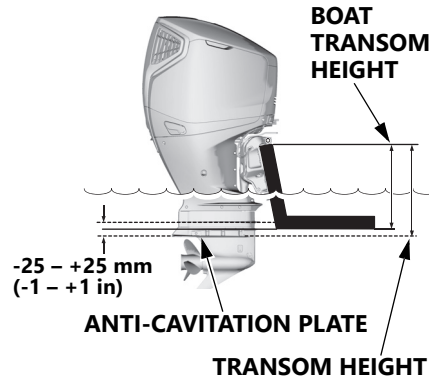

The anti-cavitation plate of the outboard motor should be within -25 - +25 mm (-1 - +1 in) from the bottom of the boat. The correct dimensions differ according to the type of boat and the configuration of the bottom of the boat. Follow the manufacturer's recommended installation height.

## OUTBOARD MOTOR INSTALLATION

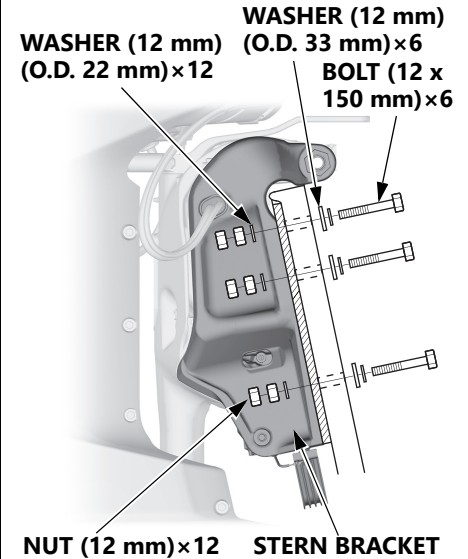

1. Apply the silicone sealant (Three Bond 1216 or equivalent) to the outboard motor mounting holes.

2. Set the outboard motor on the boat and secure with the bolts, washers, and lock nuts.

**NOTE:**

**Standard torque:**

54 N·m (5.5 kgf·m, 40 lbf·ft)

The standard torque is given just as a guideline. Torque of the nut can be different according to the material of the boat. Consult with an authorized Honda Marine outboard motor dealer.

**▲ CAUTION**

Install the outboard motor securely. Loosely mounted outboard motor can result in accidental loss of the outboard motor and damage and injury to the equipment and personnel.

## OUTBOARD MOTOR ANGLE INSPECTION (cruising)

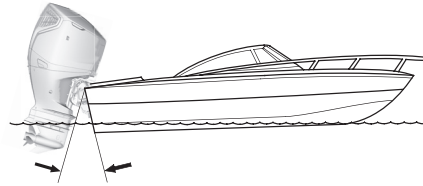

**INCORRECT  
CAUSES BOAT TO "SQUAT"**

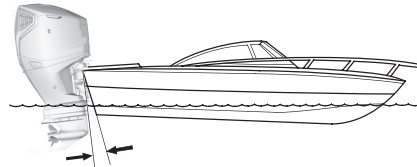

**INCORRECT  
CAUSES BOAT TO "PLOW"**

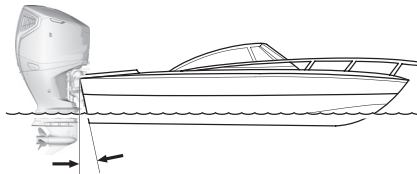

**CORRECT  
GIVES MAXIMUM PERFORMANCE**

Install the outboard motor at the best trim angle for stable cruising and maximum power.

Trim angle too large: Incorrect causes boat to "squat."

Trim angle too small: Incorrect causes boat to "plow."

The trim angle differs according to the combination of the boat, outboard motor, and propeller, and the operating conditions.

Adjust the outboard motor so that it is perpendicular to the water surface (i.e. axis of the propeller is parallel with the water surface).

# INSTALLATION

## BATTERY CONNECTIONS

### Minimum Requirements

12 V – 92 Ah/5 HR (110 Ah/20 HR)  
(CCA800)

The battery is an optional part (i.e. part to be purchased separately from the outboard motor).

### **▲ WARNING**

Batteries produce explosive gases: If ignited, an explosion can cause serious injury or blindness. Provide adequate ventilation when charging.

- **CHEMICAL HAZARD:**  
Battery electrolyte contains sulfuric acid. Contact with eyes or skin, even through clothing, may cause severe burns. Wear a faceshield and protective clothing.

- Keep flames and sparks away, and do not smoke in the area.  
ANTIDOTE: If electrolyte gets into your eyes, flush thoroughly with warm water for at least 15 minutes and call a physician immediately.
- **POISON:** Electrolyte is poison.  
ANTIDOTE:
  - External: Flush thoroughly with water.
  - Internal: Drink large quantities of water or milk. Follow with milk of magnesia or vegetable oil, and call a physician immediately.
- **KEEP OUT OF REACH OF CHILDREN.**

To protect the battery from mechanical damage and to prevent the battery from falling or tipping over, the battery must be:

- Installed in the correct size corrosion-resistant battery box.
- Properly secured in the boat.
- Secured in a location free from direct sunlight and water spray.
- Secured away from the fuel tank to avoid potential sparks near the fuel tank.

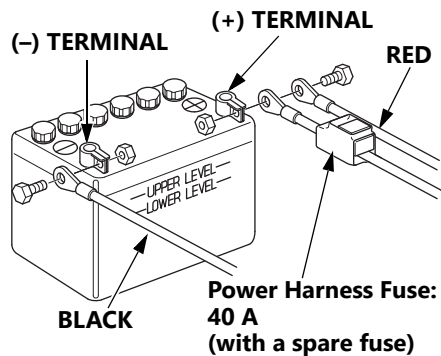

## Connect the battery cables:

1. Turn the power switch or ignition switch to "OFF".
2. Connect the cable with the red terminal cover to the positive (+) terminal of the battery.
3. Connect the cable with the black terminal cover to the negative (-) terminal of the battery.
4. Confirm that the battery cables are securely connected to the terminals without looseness or rattling.

## NOTE:

When more than one outboard motor is mounted on a boat, connect a battery to each respective outboard motor.

## NOTICE

- **Be sure to connect the (+) side battery cable first. When disconnecting the cables, disconnect the (-) side first then the (+) side.**
- **Unless the cables are properly connected to the terminals, the starter motor may fail to operate normally.**
- **Be careful to avoid connecting the battery in reverse polarity, as this will damage the battery-charging system in the outboard motor.**
- **Do not disconnect the battery cables while the engine is running. Disconnecting the cables while the engine is running will damage the**

outboard motor's electrical system.

- **Do not place the fuel tank near the battery.**
- **Battery cable extension: Extending the original battery cable will cause the battery voltage to drop due to the increased length of the cable and number of connections. This voltage drop may cause the buzzer to sound momentarily when engaging the starter motor and may prevent the outboard from starting. If the outboard starts and the buzzer sounds momentarily, there may be barely sufficient voltage reaching the engine.**

Battery posts, terminals, and related accessories contain lead and lead compounds. Wash your hands after handling them.

# INSTALLATION

## REMOTE CONTROL INSTALLATION (optional equipment)

### NOTICE

- **Improperly installed steering system, remote control box, or remote control cable, or installing those of different types could cause an unpredictable accident.**  
**Consult an authorized Honda Marine outboard motor dealer for proper installation.**

The control box is available in types as shown. Select the most suitable control box for your outboard motor considering the installation position, operability, etc. of the control box. See an authorized Honda Marine outboard motor dealer for further information.

## Remote Control Box

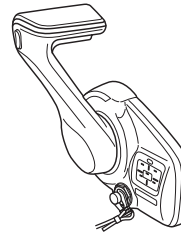

**FLUSH-MOUNT TYPE  
CONTROL BOX**

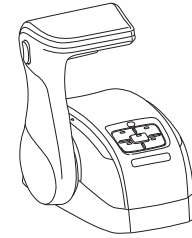

**TOP-MOUNT TYPE  
CONTROL BOX  
(FOR SINGLE OUTBOARD  
MOTOR TYPE)**

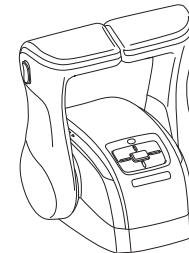

**TOP-MOUNT TYPE  
CONTROL BOX  
(FOR DUAL OUTBOARD  
MOTOR TYPE)**

## Key Switch Panel

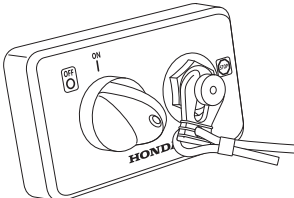

**NORMAL KEY WITH START/STOP SWITCH TYPE**

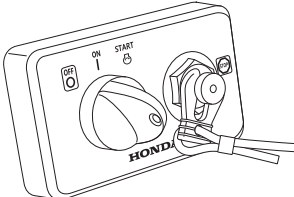

**NORMAL KEY WITHOUT START/STOP SWITCH TYPE**

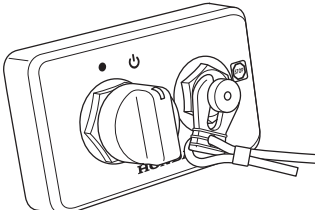

**HONDA SMART KEY TYPE  
(For US, Puerto Rico, US Virgin Islands and Canada)**

## START/STOP Switch Panel



**ALL ENGINE START  
FOR MULTIPLE  
OUTBOARD MOTORS**

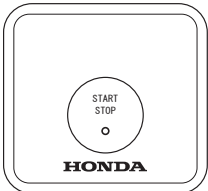

**SINGLE TYPE/  
OUTBOARD MOTOR**

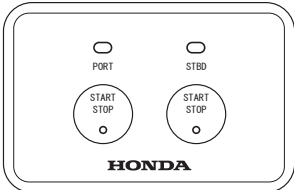

**DUAL TYPE OUTBOARD MOTOR**

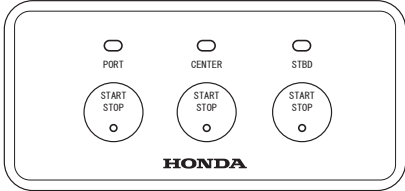

**TRIPLE TYPE OUTBOARD MOTOR**

# INSTALLATION

## Remote Control Box Location

GEARSHIFT/THROTTLE  
CONTROL LEVER  
(REMOTE CONTROL LEVER)

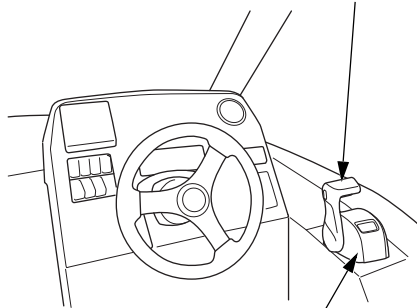

REMOTE CONTROL BOX

Install the remote control box in a position where it is easy to operate the gearshift/throttle control lever (remote control lever) and switches.

The control box position of the top-mount type should be determined in the same manner.

## PROPELLER SELECTION

Select an appropriate propeller so that the engine speed at full throttle is BF300A/BF350A:  $5,000 \text{ min}^{-1}$  (rpm) to  $6,000 \text{ min}^{-1}$  (rpm) when the boat is loaded. Engine speed varies according to the propeller size and the boat condition.

Use of the outboard motor outside the full throttle speed range will adversely affect the engine and cause serious problems. Use of the correct propeller assures powerful acceleration, top speed, excellence in terms of economy and cruising comfort, and it assures longer engine life as well. Consult with your authorized Honda Marine outboard motor dealer for proper propeller selection.

## FUEL LINE CONNECTION

Connect the fuel line to the tank and the outboard motor. Follow the boat manufacturer's instructions.

### **▲ WARNING**

Gasoline is extremely flammable, and gasoline vapor can explode, causing serious injury or death.

- Be careful not to spill fuel. Spilled fuel or fuel vapor may ignite. If any fuel is spilled, make sure the area is dry before starting the engine.
- Keep heat, sparks, and flame away.

# BEFORE OPERATION

## ARE YOU READY TO GET UNDERWAY?

Your safety is your responsibility. A little time spent in preparation will significantly reduce your risk of injury.

### Knowledge

Read and understand this manual. Know what the controls do and how to operate them.

Familiarize yourself with the outboard motor and its operation before you get underway. Know what to do in case of an emergency.

Familiarize yourself with all local laws and regulations relating to boating and the use of outboard motors.

### Safety

Always wear a PFD (Personal Flotation Device) while on the boat.

Attach the emergency stop switch lanyard securely to the operator or to the PFD worn by the operator.

## IS YOUR OUTBOARD MOTOR READY TO GO?

For your safety, and to maximize the service life of your equipment, it is very important to take a few moments before you operate the outboard motor to check its condition. Be sure to take care of any problem you find, or have your authorized marine outboard motor dealer correct it, before you operate the outboard motor.

## BEFORE OPERATION

### **⚠ WARNING**

Failure to properly maintain this outboard motor, or failing to correct a problem before operation, could result in a significant malfunction.

Some malfunctions can cause serious injuries or death.

Always perform a pre-operation inspection before each operation and correct any problems.

### **Normal Key without START/STOP Switch Type**

Before beginning your pre-operation checks, be sure the IGNITION switch is in the OFF position.

### **Normal Key with START/STOP Switch Type**

Before beginning your pre-operation checks, be sure the power switch is in the OFF position.

### **Honda Smart Key type (For US, Puerto Rico, US Virgin Islands and Canada)**

Before beginning your pre-operation checks, be sure the power switch is in the power OFF position.

### **Safety Inspection**

- Before each use, look around and underneath the engine for signs of oil or gasoline leaks.
- Check that the fuel hose is undamaged and properly connected.
- Wipe up any spills before starting the engine.
- Check the stern bracket to be sure the outboard motor is securely installed.
- Check that all controls are operating properly.
- Replace any damaged parts.
- Check that all fasteners are in place and securely tightened.

- Check the emergency stop switch for proper operation. Start the engine (P.64). Make sure the engine stops by pulling the emergency stop switch clip from the emergency stop switch.

### **Maintenance Inspection**

- Check the engine oil level (P.105). Running the engine with a low oil level can cause engine damage. Overfilling the engine can cause the engine to smoke or have oil leaks which can cause engine damage.
- When you check the oil level with the dipstick, you might notice the engine oil appears milky or the oil level has increased. If you notice either condition, change the engine oil.
- Check to be sure the propeller is undamaged and the castle nut is secured with the cotter pin (P.123).
- Check that the anodes are securely attached to the stern bracket and the gear case (P.122) and are not excessively worn. The anodes help protect the outboard motor from corrosion.
- Make sure the tool kit is onboard (P.99). Replace any missing items.
- Check the fuel level in the fuel tank (P.116).
- Check that the battery fluid is between the upper and lower levels, and the battery leads are connected securely.
- Check the fuel filter for water or sediment accumulation (P.119).
- Remove the engine cover and check for water in the outboard motor or evidence of leaks.

# OPERATION

## SAFE OPERATING PRECAUTIONS

To safely realize the full potential of this outboard motor, you need a complete understanding of its operation and a certain amount of practice with its controls.

Before operating the outboard motor for the first time, please review the IMPORTANT SAFETY INFORMATION on page 7 and the chapter titled BEFORE OPERATION.

For your safety, do not start or run the engine in a confined or partly enclosed area. Your engine's exhaust contains poisonous carbon monoxide, a colorless, odorless gas that can collect rapidly. Breathing carbon monoxide can cause loss of consciousness and may lead to death.

### **⚠ WARNING**

Exhaust contains poisonous carbon monoxide gas that can build up to dangerous levels in closed areas.

Breathing carbon monoxide can cause unconsciousness or death.

Never run this product's engine in a closed, or even partly closed area.

## BREAK-IN PROCEDURE

### **Break-in period: 10 hours**

Proper break-in operation allows the moving parts to wear in smoothly for best performance and long service life. Avoid continuous operation at a steady speed.

#### **First 15 minutes:**

Run the engine at trolling speed. Use the minimum throttle opening necessary to operate the boat at a safe trolling speed.

#### **Next 45 minutes:**

Run the engine up to a maximum of 2,000 to 3,000  $\text{min}^{-1}$  (rpm), which is about 10% to 30% of maximum throttle opening. Operating at a maximum of 2,000 to 3,000  $\text{min}^{-1}$  (rpm) should be limited to 50% of the 45 minutes.

## Next 60 minutes:

Run the engine up to a maximum of 4,000 to 5,000  $\text{min}^{-1}$  (rpm), which is about 50% to 80% of maximum throttle opening. Operating at a maximum of 4,000 to 5,000  $\text{min}^{-1}$  (rpm) should be limited to 50% of the 60 minutes.

30-second full-throttle bursts are OK, but do not operate the engine continuously at full throttle.

For boats that plane easily, bring the boat up on plane, and then reduce the throttle opening to the recommended rpm range.

## Next 8 hours:

Do not run the engine at full throttle for more than 5 minutes at a time.

## FUEL PRIMING

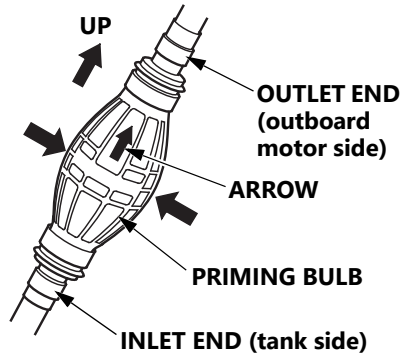

Hold the priming bulb up in the direction of the arrow; then squeeze the priming bulb several times until it feels firm, indicating that fuel has reached the engine.

Check to be sure there are no fuel leaks before starting the engine.

Do not touch the priming bulb while the engine is running or when tilting up the outboard motor. The vapor separator could overflow.

## ⚠ WARNING

Gasoline is highly flammable and explosive.

You can be burned or seriously injured when handling fuel.

- Stop the engine and let it cool before handling fuel.
- Keep heat, sparks, and flame away.
- Handle fuel only outdoors.
- Keep away from your vehicle.
- Wipe up spills immediately.

# OPERATION

## INFREQUENT OR OCCASIONAL USE

If your outboard motor will be used on an infrequent or intermittent basis, please refer to the fuel section of the STORAGE chapter (P.130) for additional information regarding fuel deterioration.

## STARTING THE ENGINE

Make sure the boat's battery switch is ON before turning ON the ignition switch or power switch. If the battery switch is OFF while attempting to start the engine, the buzzer will sound three times.

### EMERGENCY STOP SWITCH

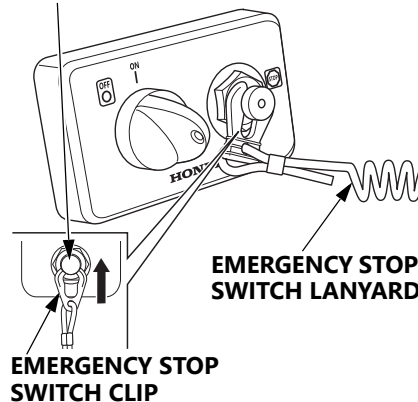

### NOTICE

- **To prevent damage to the outboard from overheating, never run the engine with the propeller out of water.**

### NOTE:

When the boat is equipped with two outboard motors, perform the following on the right and left engines respectively.

1. Put the emergency stop switch clip in the emergency stop switch, and attach the emergency stop switch lanyard securely to the operator or to the operator's PFD (Personal Flotation Device).

The engine will not start or run unless the emergency stop switch clip is in the emergency stop switch.

The emergency stop switch clip and emergency stop switch

lanyard system is a safety device that will stop the engine if you fall away from the controls while operating the boat.

Always attach the emergency stop switch lanyard securely to the operator or to the operator's PFD before starting the engine.

2. Set the control lever in the NEUTRAL position. The engine will not start if the FORWARD or REVERSE gears are engaged.

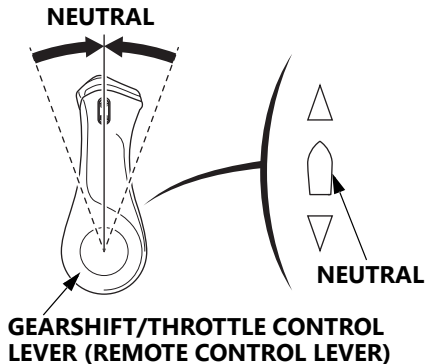

## (Normal Key without START/STOP Switch Type)

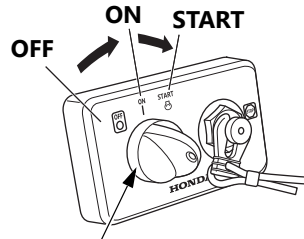

### IGNITION SWITCH

3. Turn the ignition switch to the START position until the engine starts. When the engine starts, release the switch, allowing it to return to the ON position. Go to step 5.

## (Normal Key with START/STOP Switch Type)

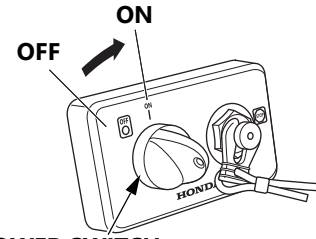

### POWER SWITCH

3. Insert the key into the power switch and turn it to the ON position.

### START/STOP SWITCH

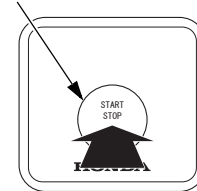

4. Push the start/stop switch.

## OPERATION

(Honda Smart Key Type (For US, Puerto Rico, US Virgin Islands and Canada))

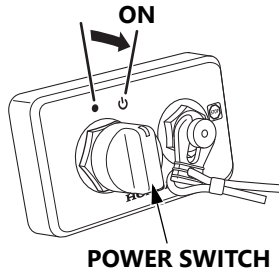

3. Turn the power switch to the right. The power will not be turned ON unless the Honda Smart Key is authenticated.
4. Push the start/stop switch. When the boat is equipped with two outboard motors, push the all engine start switch.

### NOTICE

- The starter motor consumes a large amount of current. Do not run it continuously. If the engine does not start, wait at least 10 seconds before running the starter motor again.
5. Before getting underway, allow the engine to warm-up sufficiently to ensure good performance.  
If the temperature is above 5°C (41°F), allow the engine to idle for at least 3 minutes to warm up.  
Below 5°C (41°F), warm-up the engine for at least 5 minutes at 2,000 min<sup>-1</sup> (rpm). Press the fast idle button to activate it, and then use the throttle lever to achieve approximately 2,000 min<sup>-1</sup> (rpm).

### NOTICE

- If the engine is not properly warmed up before raising the engine speed, the buzzer and overheat indicator may activate and the engine speed will be automatically reduced.
- The cooling system may freeze in areas where the temperature reaches 0°C (32°F) or below. Cruising at high speed without warming the engine up may cause engine damage.

During the warm-up period, check the low oil pressure indicator (P.46), overheat indicator (P.47), and cooling system indicator (P.47).

If the indicators show any abnormal condition, immediately stop the engine and determine the cause of the problem. Refer to **TAKING CARE OF UNEXPECTED PROBLEMS** on P.139.

## Active Mode

### FLUSH-MOUNT TYPE

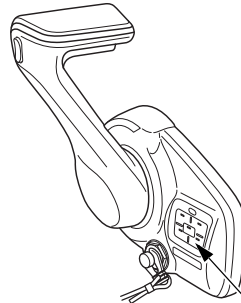

**ACTIVE SWITCH**

### SINGLE TOP-MOUNT TYPE

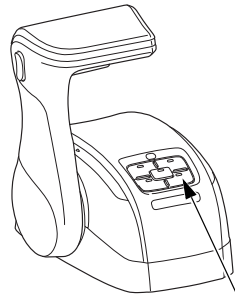

**ACTIVE SWITCH**

### DUAL TOP-MOUNT TYPE

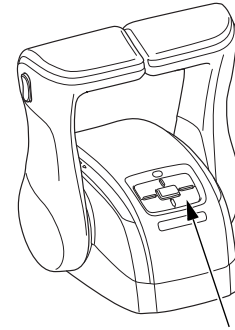

**ACTIVE/FAST IDLE SWITCH**

For multiple station type, use the ACTIVE switch or ACTIVE/FAST IDLE switch to change the operating remote control (active mode). If you press the ACTIVE switch or ACTIVE/FAST IDLE switch on the remote control you want to operate the outboard motors when all gearshift/throttle control levers (remote control levers) are in the NEUTRAL position, the mode changes to active mode.

## OPERATION

- To release the remote control selection, press the ACTIVE switch or ACTIVE/FAST IDLE switch on the remote control that is not in active mode, with all the gearshift/throttle control levers (remote control levers) put in the NEUTRAL position.

### STOPPING THE ENGINE

After stopping the engine, be sure to turn OFF the ignition switch or power switch before turning OFF the boat's battery switch. If the battery switch is turned OFF while the ignition switch or power switch is ON, the buzzer will sound three times briefly.

### Emergency Engine Stopping

#### EMERGENCY STOP SWITCH CLIP

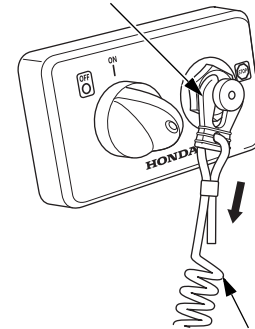

#### EMERGENCY STOP SWITCH LANYARD

To stop the engine in an emergency, pull the emergency stop switch clip out of the emergency stop switch by pulling the emergency stop switch lanyard.

If the emergency stop switch is activated while the engine is running, the engine will shut down abruptly and the boat will quickly decelerate, potentially causing occupants and objects to be thrown forward and/or overboard.

If the emergency stop switch is activated, the emergency stop switch clip must be reinserted before the engine can be restarted.

We suggest that you stop the engine this way occasionally to verify that the emergency stop switch is operating properly.

Before leaving the dock, check the operation of the emergency stop switch.

Turn the ignition switch to the OFF position after verifying the emergency stop switch operation.

### NOTICE

- **When you have stopped the engine with the emergency stop switch, be sure to turn off the ignition switch or the power switch. Leaving the ignition switch or power switch ON will drain the battery.**

## Normal Engine Stopping

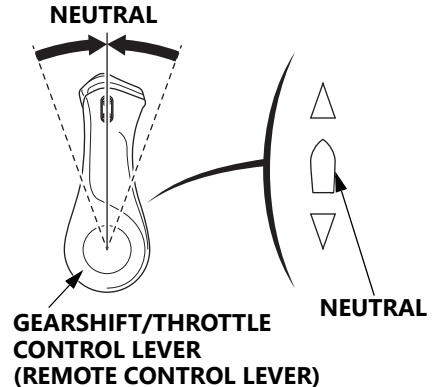

1. Move the control lever(s) to the NEUTRAL position. After cruising at full throttle, cool down the engine by idling for a few minutes before stopping the engine.

### NOTICE

- **To keep the engine in good condition, always run the engine at idling speed for more than one minute before stopping it. Failure to do so may result in engine malfunction.**

# OPERATION

(with START/STOP switch type)

## START/STOP SWITCH

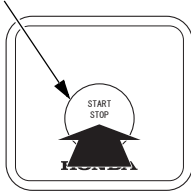

2. Push the start/stop switch to stop the engine.
  - In the event that the engine does not stop when the start/stop switch is pushed, turn the power switch to the OFF position or pull the emergency stop switch clip out of the emergency stop switch by pulling the its lanyard (P.68).  
After stopping the engine, consult the authorized marine outboard motor dealer.

Normal Key Type

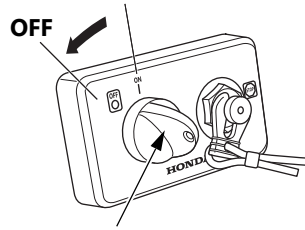

## POWER SWITCH

3. Turn the power switch to the OFF position to turn the power OFF.
4. When the boat is not in use, remove and store the ignition switch key and the emergency stop switch clip and lanyard.

Honda Smart Key Type (For US, Puerto Rico, US Virgin Islands and Canada)

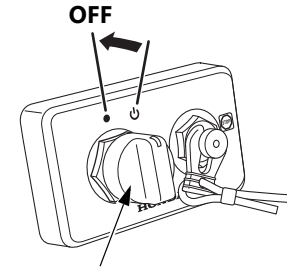

## POWER SWITCH

3. Turn the power switch to the right or press the lock button on the Honda Smart Key to turn the power OFF.
4. When the boat is not in use, remove and store the emergency stop switch clip and lanyard.

## (Normal Key without START/STOP Switch type)

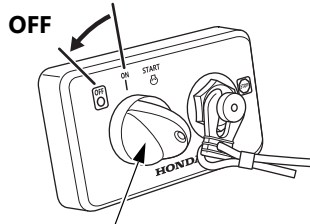

**IGNITION SWITCH**

2. Turn the ignition switch to the OFF position to stop the engine.
  - In the event that the engine does not stop when the ignition switch is turned to the OFF position, pull the emergency stop switch clip out of the emergency stop switch by pulling the emergency stop switch lanyard (P.68). After stopping the engine, consult the authorized marine outboard motor dealer.

3. When the boat is not in use, remove and store the ignition switch key and the emergency stop switch clip and lanyard.

## GEARSHIFT AND THROTTLE OPERATION

### *Flush-Mount Type*

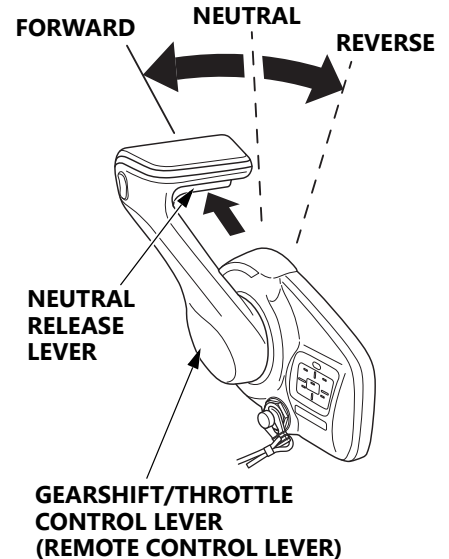

# OPERATION

## Top-Mount Type

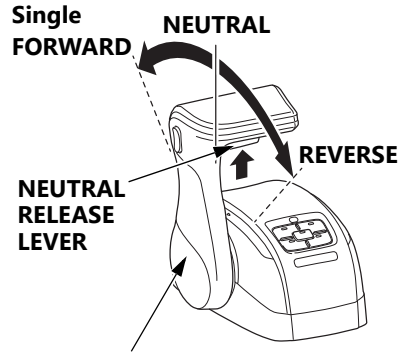

GEARSHIFT/THROTTLE CONTROL LEVER (REMOTE CONTROL LEVER)

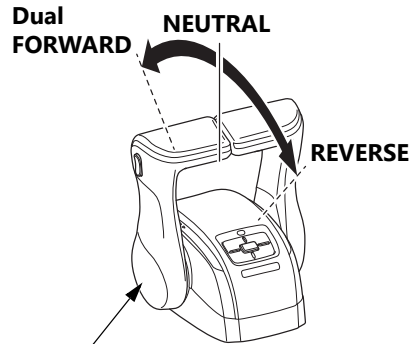

GEARSHIFT/THROTTLE CONTROL LEVER (REMOTE CONTROL LEVER)

## ⚠ CAUTION

Avoid sharp and abrupt operation of the control lever. Operate it moderately. Operate the control lever and raise the engine speed after making sure that the gear was shifted securely.

To shift gears, move the control lever to select the FORWARD, NEUTRAL, or REVERSE gear.

The control lever cannot be moved from the NEUTRAL position unless the neutral release lever is squeezed (Flush-mount type, Single top-mount type).

When cruising normally, operate the right and left levers simultaneously or operate in one-lever mode (see one-lever mode on page 81). (Dual top-mount type)

Moving the control lever beyond the gear selection range increases engine speed.

## Gearshift/Throttle Control Lever (Remote Control Lever) Friction

Adjust the control lever friction.

### NOTICE

- **Adjust the control lever friction while the engine is stopped.**

## Flush-Mount Type

1. Insert a screwdriver or similar tool into the grooves on the body cover and remove the tabs securing the body cover.

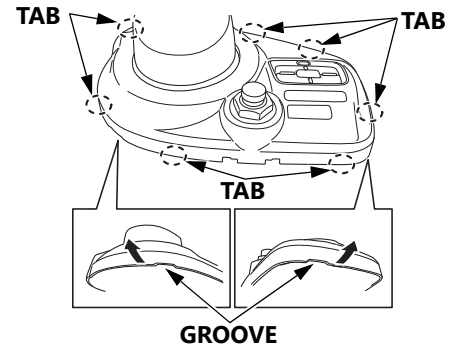

2. Remove the body cover.

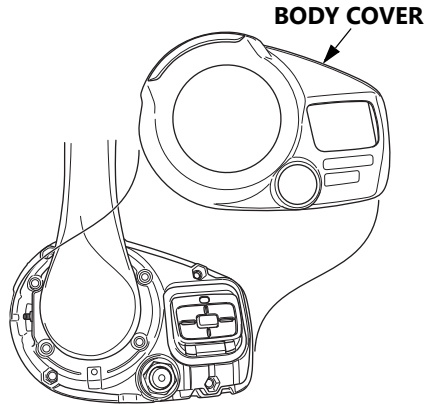

3. Loosen the nut.

4. Turning the control lever friction adjustment bolt clockwise (to the right) makes it heavier. Turning the bolt counterclockwise (to the left) makes it lighter.

5. Tighten the nut to lock the control lever friction adjustment bolt.

6. Attach the body cover.

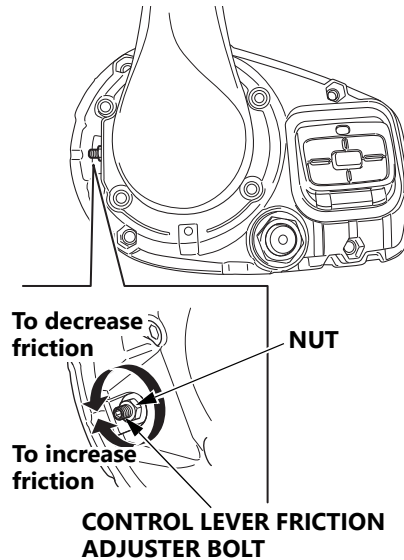

**Top-Mount Type**

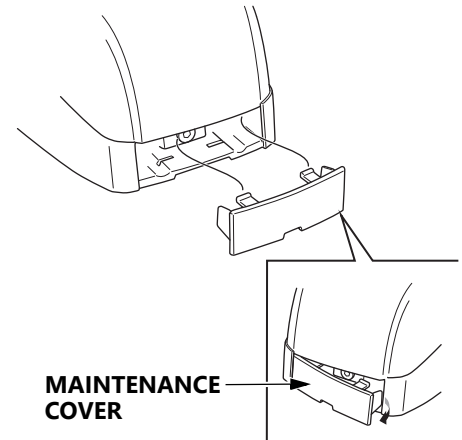

1. Remove the maintenance cover.

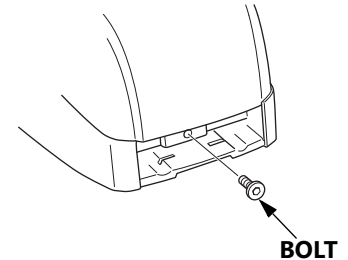

2. Remove the bolt.

## OPERATION

### REMOTE CONTROL COVER

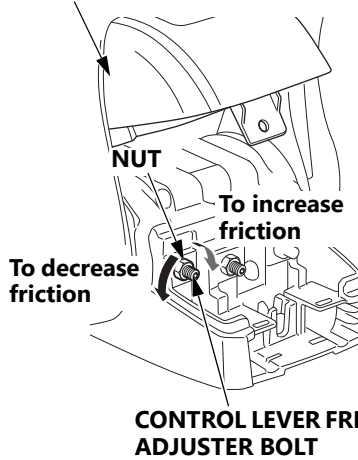

3. Open the remote control cover.
4. Loosen the nut.
5. Turning the control lever friction adjustment bolt clockwise (to the right) makes it heavier. Turning the bolt counterclockwise (to the left) makes it lighter.

6. Tighten the nut to lock the lever friction.
7. Reinstall the remote control cover.
8. Install and tighten the bolt.
9. Reinstall the maintenance cover.

## STEERING

Steer the boat in the same manner as an automobile.

Under normal conditions, turning the steering wheel counterclockwise will make the boat turn left and turning the steering wheel clockwise will make the boat turn right.

## CRUISING

### Engine Speed

For best fuel economy, limit the throttle opening to 80%. Use the throttle friction control (P.72) to help you hold a steady speed.

For rough water conditions or large waves, slow down to prevent the propeller from rising out of the water.

The engine is equipped with a rev limiter to prevent the possibility of mechanical damage from excessive engine speed.

If, for example, the outboard motor is tilted excessively or propeller ventilation occurs during a sharp turn, the engine may overrev, activating the rev limiter.

If engine speed becomes unstable at high speed due to activation of the rev limiter, reduce speed and check the trim angle of the outboard motor.

### **⚠ WARNING**

Traveling at high speeds may cause the boat to loss of control in some water conditions, which could result in damage to the outboard motor and injury to the occupants.

Always travel at safe speeds for the water conditions.

### **⚠ CAUTION**

Do not operate without the engine cover. Exposed moving parts could cause injury; water may damage the engine.

## Trim

Use the power trim/tilt switch to trim the outboard motor for the best performance and stability.

You can use the power trim/tilt switch at any time, whether the boat is underway or stopped.

Press the UP or DN (down) side of the switch to adjust the angle of the outboard motor.

Refer to the multi-function display or NMEA2000<sup>®</sup>-compatible display for an indication of whether the outboard motor is trimmed high or low.

## OPERATION

### ⚠ WARNING

When the boat is equipped with two outboard motors, adjust with the switch on the control lever side. Adjustment with the switch on the console side will impair the balance between the right and left outboard motors, which adversely affects operability and stability of the outboard motors.

### ⚠ CAUTION

Improper trim angle results in unstable steering condition.

- Do not trim excessively while cruising through rough waves, or it may cause an accident.
- Excessive ventilation trim angle can result in cavitation and racing of the propeller, and trimming up the outboard motor excessively can cause damage to the water pump and engine.

It is necessary to trim the angle of the outboard motor to compensate for changes in boat load, weight distribution, water conditions, and propeller selection.

Under normal conditions, the boat will perform best when the anti-cavitation plate is level with the water surface.

When cruising into a high wind, trim the outboard motor down slightly to level the boat and improve stability. With a tail wind, trim the outboard motor up slightly.

### NOTICE

- **Excessive trim/tilt angle during operation can cause propeller ventilation, overheating, and water pump damage.**

### *Flush-Mount Type*

**GEARSHIFT/THROTTLE CONTROL LEVER (REMOTE CONTROL LEVER)**

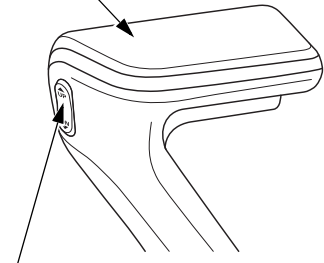

**POWER TRIM/TILT SWITCH**

## Top-Mount Type

### SINGLE TYPE

GEARSHIFT/THROTTLE CONTROL LEVER (REMOTE CONTROL LEVER)

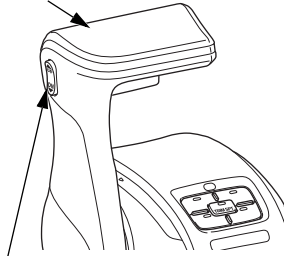

POWER TRIM/TILT SWITCH

### DUAL TYPE

GEARSHIFT/THROTTLE CONTROL LEVERS (REMOTE CONTROL LEVERS)

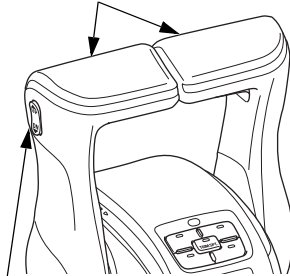

POWER TRIM/TILT SWITCH

## Power Trim/Tilt Switch Panel

### DUAL TYPE

Press UP to raise bow.

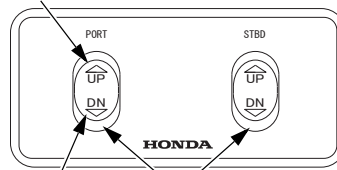

POWER TRIM/TILT SWITCHES

Press DN to lower bow.

### TRIPLE TYPE

Press UP to raise bow.

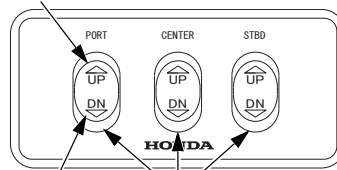

POWER TRIM/TILT SWITCHES

Press DN to lower bow.

For multiple outboard motors, the trim/tilt angle of all outboard motors is adjusted at the same time by using the power trim/tilt switch on the gearshift/throttle control lever (remote control lever) and the trim/tilt angle of each outboard motor is adjusted by using each power trim/tilt switch on the panel.

# OPERATION

**OUTBOARD MOTOR TRIMMED TOO LOW**

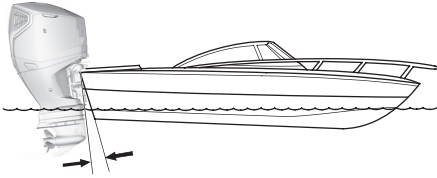

**OUTBOARD MOTOR TRIMMED TOO HIGH**

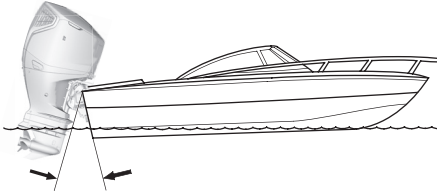

**OUTBOARD MOTOR TRIMMED CORRECTLY**

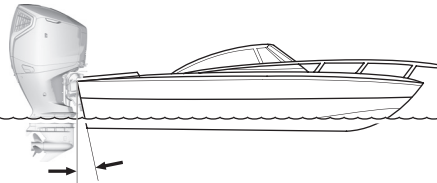

**BOW TOO LOW DUE TO**

- 1. LOAD IN THE FRONT**
- 2. OUTBOARD MOTOR TRIMMED TOO LOW**

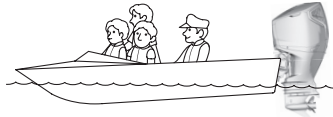

**BOW TOO HIGH DUE TO**

- 1. LOAD IN THE REAR**
- 2. OUTBOARD MOTOR TRIMMED TOO HIGH**

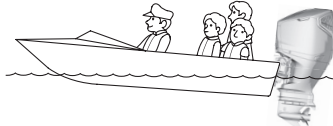

## Trim Support Mode

(Flush-mount type)

**POWER TRIM/TILT SWITCH**

Press UP to raise bow.

Press DN to lower bow.

**GEARSHIFT/THROTTLE CONTROL LEVER (REMOTE CONTROL LEVER)**

**TRIM SPT. SWITCH**

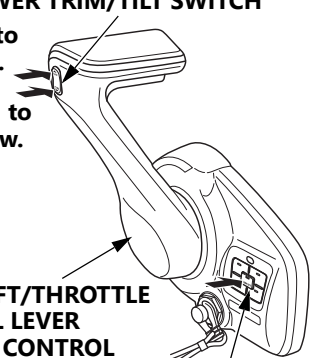

(Top-mount type)

## POWER TRIM/TILT SWITCH

Press UP to raise bow.

Press DN to lower bow.

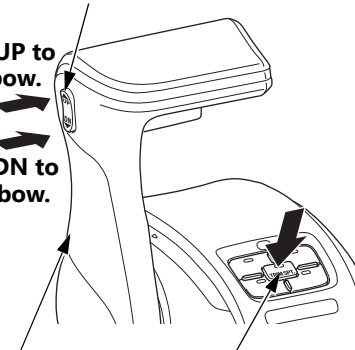

TRIM SPT. SWITCH

GEARSHIFT/THROTTLE CONTROL LEVER (REMOTE CONTROL LEVER)

Pressing the TRIM SPT. switch changes the mode to the trim support mode, which automatically does trim operations according to the speed or engine RPM.

Adjusting the trim angle to an optimum position automatically during acceleration or cruising improves acceleration performance, top speed, steering stability, fuel efficiency, etc.

The conditions that control the trim angle pattern is set in the Honda multi-function display.

You can finely adjust the trim angle manually while in trim support mode.

In the case of a single outboard motor, if you press the power trim/tilt switch of the remote control while in trim support mode, you can fine-tune the trim angle.

In the case of multiple outboard motors, if you press the power trim/tilt switch of the remote control in the trim support mode, you can fine-tune the trim angles of all the outboard motors simultaneously.

The finely adjusted angle is temporarily overwritten with the preset pattern, and returns to the pattern before overwriting when the trim support mode is released or the ignition switch or power switch is turned off.

## OPERATION

If you use the cruise control mode while in the trim support mode, the trim support mode is temporarily stopped.

The trim support mode is forcibly canceled in the following cases.

- Trim/tilt angle is adjusted beyond the trim area by the power trim/tilt switch
- GPS error or disconnection
- Engine malfunction (overheating, low oil pressure, etc.)
- Trim operation abnormality
- Accelerating or decelerating so quickly as to put a load on trim

### TROLLING CONTROL MODE

(Flush-mount type)

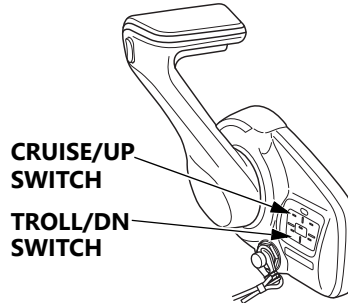

(Top-mount type)

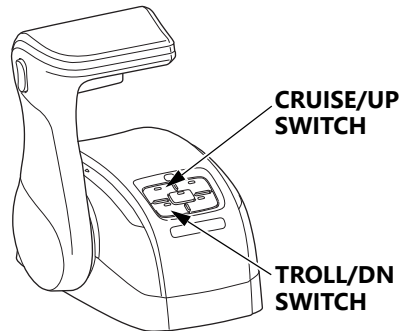

TROLL/DN Switch: Reduce engine speed

CRUISE/UP Switch: Increase engine speed

After the engine warms up, when the gearshift/throttle control levers (remote control levers) are tilted from the NEUTRAL position to the FORWARD or REVERSE side by about 20° and the TROLL/DN switch of the remote control is pressed, the mode changes to trolling control mode.

A long buzz sounds once. When the mode is changed to trolling control mode, the engine speed is 650 min<sup>-1</sup> (rpm).

You can adjust the engine speed by 50 min<sup>-1</sup> (rpm) every time you press the switch once. You will hear a short buzz.

The engine speed can be adjusted within the range of 650 to 1,000  $\text{min}^{-1}$  (rpm).

Continuing to press the switch will not decrease or increase the engine speed beyond the lower (650  $\text{min}^{-1}$  (rpm)) or higher (1,000  $\text{min}^{-1}$  (rpm)) limit.

If you try to do this, a short buzz sounds twice.

The throttle may be operated while in trolling control mode.

## ONE-LEVER MODE (Dual top-mount type)

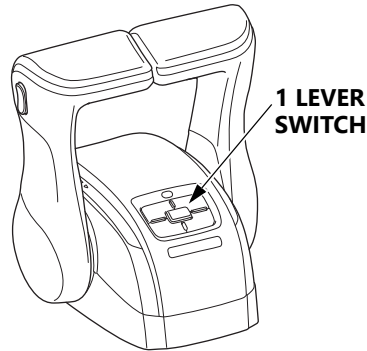

Shifting gear and the engine speed adjustment of all the outboard motors can be performed with one gearshift/throttle control lever (remote control lever) when in one-lever mode.

If you press the 1 LEVER switch when all gearshift/throttle control levers (remote control levers) are in the NEUTRAL position, the mode changes to one-lever mode. A long buzz sounds once.

## CRUISE CONTROL MODE

(Flush-mount type)

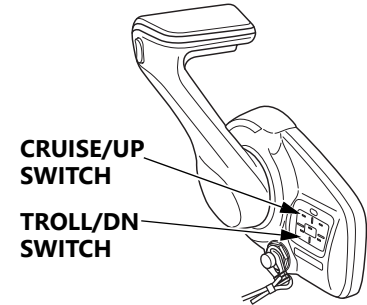

(Top-mount type)

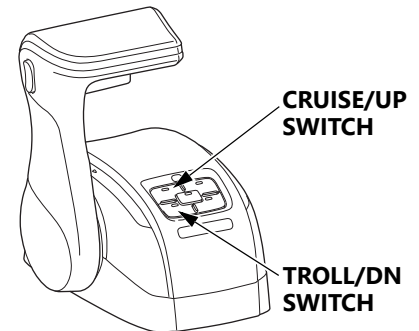

## OPERATION

---

TROLL/DN Switch: Reduce engine speed or velocity

CRUISE/UP Switch: Increase engine speed or velocity

If you press the CRUISE/UP switch during cruising with all the gearshift/throttle control levers (remote control levers) in the FORWARD position, the mode changes to the cruise control mode, which lets the boat cruise at a constant engine speed or velocity.

A long buzz sounds once.

- Boat speed can only be adjusted in cruise control mode when equipped with GPS.

You can adjust the engine speed or velocity by every time you press the switch once. You will hear a short buzz.

Continuing to press the switch will not decrease or increase the engine speed beyond the lower or higher limit.

If you try to do this, a short buzz sounds twice.

### **Engine speed adjusting range:**

Engine speed at mode change  $\pm 500 \text{ min}^{-1}$  (rpm) (in steps of  $50 \text{ min}^{-1}$  (rpm))

Velocity adjusting range:

- Velocity at mode change  $\pm 10 \text{ km/h}$  (in steps of  $1.0 \text{ km/h}$ )
- Velocity at mode change  $\pm 5 \text{ miles/h}$  (in steps of  $0.5 \text{ miles/h}$ )
- Velocity at mode change  $\pm 5 \text{ knots}$  (in steps of  $0.5 \text{ knots}$ )

The cruise control mode is released forcibly in the following cases.

- GPS error or disconnection (Velocity adjustment is selected in the multifunction display)
- Operate the gearshift/throttle control lever (remote control lever) a certain amount from the position for changing modes
- Engine stops or engine is abnormal (overheating, low oil pressure, etc.)
- If the engine RPM or speed is unstable

## SHALLOW WATER OPERATION

When operating in shallow water, use the power trim/tilt switch (P.76) to tilt the outboard motor so that the propeller and gear case won't hit the bottom.

Proceed at low speed, and monitor water flow from the cooling system indicator (P.47) to be sure the outboard motor is not tilted so high that the water intakes are out of the water.

### NOTICE

- **An excessive trim/tilt angle during operation can cause propeller ventilation, overheating, and water pump damage. This type of damage is not covered by the warranty.**

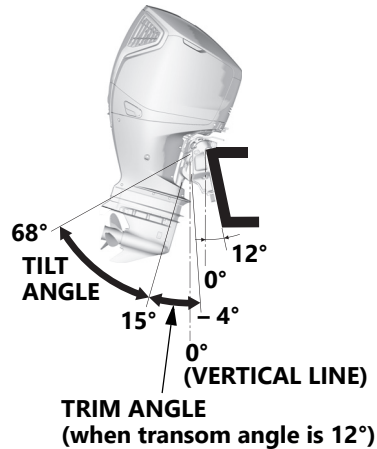

## MOORING, BEACHING, LAUNCHING

Stop the engine before tilting the outboard motor.

Before tilting an outboard motor up, leave it in the running position for one minute after stopping the engine to drain the water from inside the engine.

### NOTICE

- **Use the tilt lock lever when mooring for long time (P.85).**
1. Move the gearshift/throttle control lever (remote control lever) to the NEUTRAL position and stop the engine.
  2. Press UP on the power trim/tilt switch and tilt the outboard motor to the best position according to cruising conditions.

# OPERATION

Pressing UP on the power trim/tilt switch on the gearshift/throttle control lever (remote control lever) or power trim/tilt switch panel twice in succession tilts up the outboard motor to the set tilt angle automatically.

## NOTICE

- **Do not tilt up the outboard motor before shutting off the engine, or it may cause malfunction.**
- **When mooring the boat in temperature reaches 0°C (32°F) or below, submerge the gear case underwater to prevent freezing of the cooling water intake port and inside the gear case.**

## Flush-Mount Type

GEARSHIFT/THROTTLE CONTROL LEVER (REMOTE CONTROL LEVER)

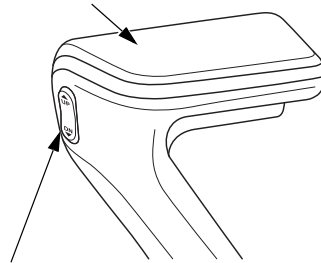

POWER TRIM/TILT SWITCH

## Top-Mount Type

SINGLE TYPE

GEARSHIFT/THROTTLE CONTROL LEVER (REMOTE CONTROL LEVER)

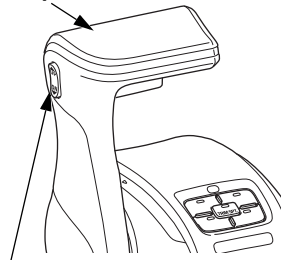

POWER TRIM/TILT SWITCH

## DUAL TYPE

GEARSHIFT/THROTTLE CONTROL LEVERS (REMOTE CONTROL LEVERS)

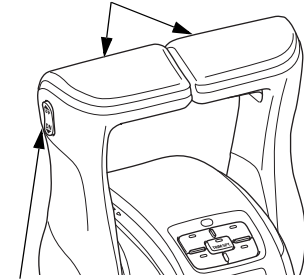

POWER TRIM/TILT SWITCH

## Power Trim/Tilt Switch Panel

DUAL TYPE

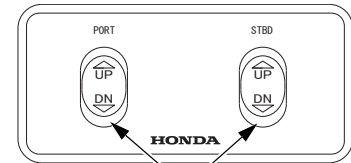

POWER TRIM/  
TILT SWITCHES

## TRIPLE TYPE

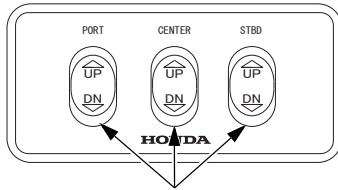

**POWER TRIM/  
TILT SWITCHES**

### NOTICE

- **For multiple outboard motors, the trim/tilt angle of all outboard motors is adjusted at the same time by using the power trim/tilt switch on the gearshift/throttle control lever (remote control lever) and the trim/tilt angle of each outboard motor is adjusted by using each power trim/tilt switch on the panel.**

## Moorage



**TILT LOCK LEVER (each side)**

Tilt up the outboard motor using the tilt lock levers when mooring the boat. Shift the gearshift/throttle control lever (remote control lever) into the NEUTRAL position and stop the engine before tilting up the outboard motor.

### NOTICE

- **Before tilting it up, leave the outboard motor in the running position for one minute after stopping the engine to drain the water from inside the engine.**

Stop the engine before tilting the outboard motor.

1. Tilt the outboard motor up to its highest position using the power trim/tilt switch (P.37).
2. Move the tilt lock levers to the LOCK position and lower the outboard motor until the lock levers contact the stern bracket.

## OPERATION

When tilted up to 65°

**TILT LOCK LEVER (each side)**

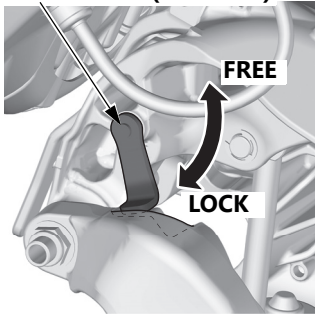

When tilted up to 55°

**TILT LOCK LEVER (each side)**

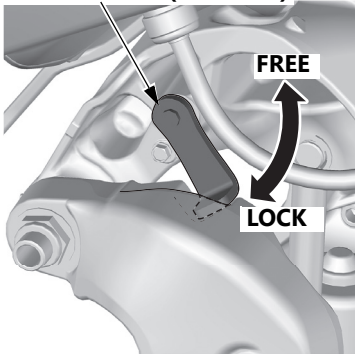

If it is not possible to tilt up to 65°, due to the hull, lock the outboard motor at 55°.

### ⚠ CAUTION

If you do not secure the outboard motor with the tilt lock levers after you tilt up the outboard motor by 55° or 65° or more, then the hydraulic pressure of the power trim/tilt may drop and cause the outboard motor to tilt down.

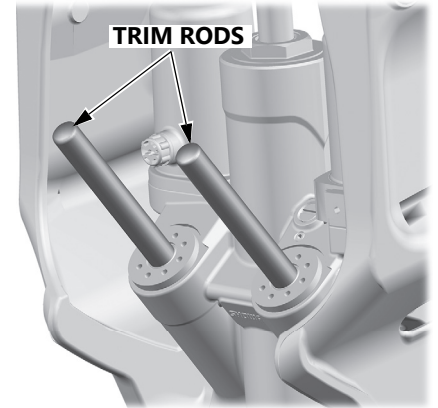

3. Press DN (down) on the power trim/tilt switch to fully shorten the trim rods.

4. To tilt down, raise the outboard motor as far as it goes using the power trim/tilt switch, move the tilt lock levers to the FREE position, and lower the outboard motor to the designated position.

## NOTICE

- **Do not start the engine while the tilt lock lever is locked. There is a risk of damaging the engine.**

Pressing DN on the power trim/tilt switch on the gearshift/throttle control lever (remote control lever) or power trim/tilt switch panel twice in succession tilts the outboard motor down to the set tilt angle automatically (P.87).

## Automatic Tilt Mode

If you press the power trim/tilt switch twice in succession while the boat is stopped, the automatic tilt mode is turned on, automatically tilting the outboard motor up or down.

When the "UP" side of the power trim/tilt switch is pressed twice in succession, the buzzer sounds once at a long interval, and the tilt is automatically raised to the preset tilt limit position. The buzzer continues to sound at short intervals while the outboard motor is tilted up.

When you press "DN" on the power trim/tilt switch twice in succession, the buzzer sounds once at a long interval, and the outboard motor is automatically tilted down to the preset tilt limit position. The buzzer continues to sound at short intervals while the outboard motor is tilted down.

The automatic tilt mode can not be turned on by operating the power tilt switch on the outboard motor.

Even during automatic tilting, automatic tilt will be forcibly canceled and the outboard motor will stop being tilted in the following cases.

- The power trim/tilt switch is pressed during automatic tilt operations
- The power tilt switch (outboard motor panel) is pressed and held in the opposite direction

## OPERATION

of the tilt direction during automatic tilt operations

- Any of the engines are started
- Any of the engines are abnormal (overheating, low oil pressure, etc.)

Before you can use the automatic tilt function, you need to set it in the Honda multi-function display.

For multiple outboard motors, the power trim/tilt switch on the gearshift/throttle control lever (remote control lever) side can turn on the automatic tilt mode for all the outboard motors and the power trim/tilt switch on the power trim/tilt switch panel can turn on the automatic tilt mode for each individual outboard motor.

The power trim/tilt switch on the gearshift/throttle control lever (remote control lever) side turns on the automatic tilt mode even if the power switch or ignition switch is off.

### Power Tilt Switch (Outboard Motor Panel)

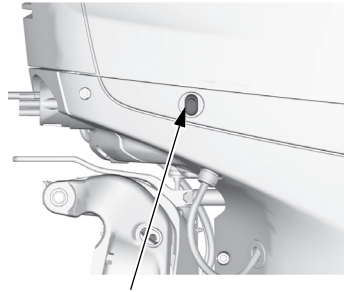

**POWER TILT SWITCH**

When you are away from the power trim/tilt switch on the gearshift/throttle control lever (remote control lever), you can operate the power tilt switch on the outboard motor.

- Press the switch on the “UP” side to increase the tilt angle.
- Press the switch on the “DN” side to decrease the tilt angle.

### **⚠ CAUTION**

Do not operate the power tilt switch on the outboard motor while cruising. You can lose control of your balance, fall, and be injured by the moving outboard, propeller, or boat. Always use the gearshift/throttle control lever (remote control lever) or the power trim/tilt switch on the switch panel while under way.

### **NOTICE**

- **Do not attempt to use the power tilt switch to tilt the outboard motor down while the tilt lock levers are in the LOCK position. Damage to the power tilt system may occur.**

## Manual Relief Valve

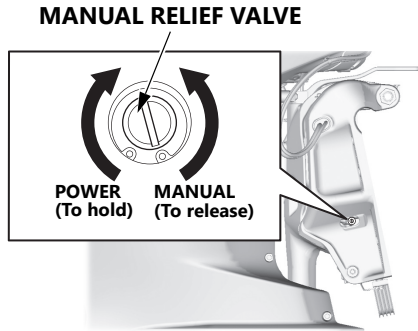

If the power trim/tilt switch cannot be used, you can open this valve to do manual tilt-down.

For manual tilting, use a screwdriver to turn the valve counterclockwise 1 or 2 turns. Close the valve firmly after positioning the engine.

### **⚠ DANGER**

Check that nobody is under the outboard motor before opening the manual relief valve. If the manual relief valve is loosened (turned counterclockwise) when the outboard motor is tilted up, the outboard motor will suddenly tilt down.

### **⚠ CAUTION**

The manual relief valve must be tightened securely before operating the outboard motor otherwise the outboard motor could tilt when operating in reverse.

### **NOTICE**

- **If there is not enough clearance to the ground, opening the manual relief valve may cause the outboard motor to contact the ground and be damaged.**

## MULTIPLE OUTBOARD MOTORS

On boats equipped with more than one outboard motor, all motors normally operate at the same time.

If one or more motor(s) is stopped while the other(s) is running, put the stopped motor in NEUTRAL and tilt it up so its propeller is above the water's surface.

If the propeller of the stopped motor is left in the water, it may turn as the boat moves through the water, causing a reverse flow of water from the exhaust side. Reverse flow can cause an engine malfunction.

# OPERATION

## NOTICE

- **If one outboard is down and another outboard is tilted all the way up, it may cause extreme steering angles that can cause the outboard cowlings to touch and damage each other.**
- **Never use the tilt lock lever if a stopped motor is tilted up. There is a risk of damaging the motor if you use the tilt lock lever while cruising.**

## TURNING WHEN MULTIPLE ENGINES ARE MOUNTED

When maneuvering in narrow waters, the action of the outboard motors allows the boat to turn more easily if you operate the left and right control levers separately. Contact the dealer where you purchased your outboard motors or authorized marine outboard motor dealer.

### **⚠ WARNING**

When cruising normally, shift the left and right control levers at the same time. If you shift them one at a time, the boat may become unstable and capsize.

For boats with triple DBW type outboard motors, initial setup by the dealer improves turning ability.

Contact the dealer where you purchased your outboard motors or an authorized marine outboard motor dealer for more information.

In the following cases, the boat cannot be turned by operating the throttle.

- When only a single engine is mounted
- When using one-lever mode

## Turning right (forward)

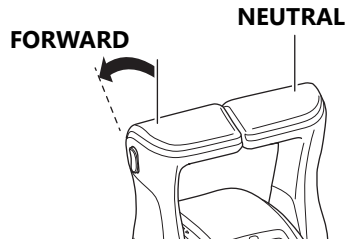
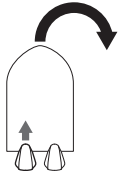

## Turning left (forward)

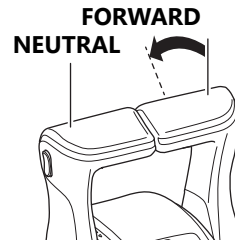
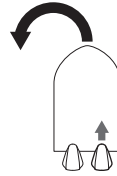

## Turning right (reverse)

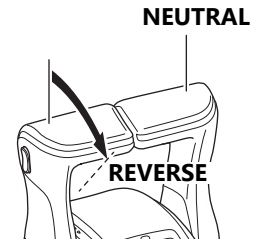
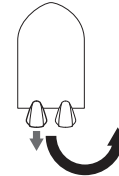

# OPERATION

## Turning left (reverse)

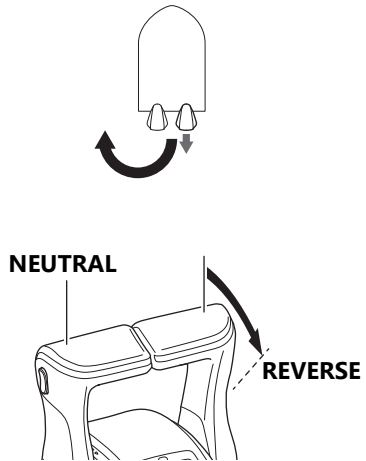

## Turning right (spin)

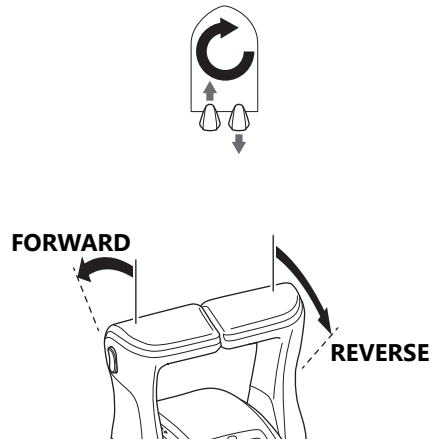

## Turning left (spin)

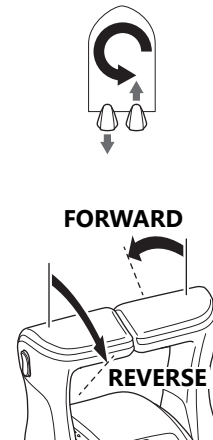

**ENGINE PROTECTION SYSTEM**

**Engine Oil Pressure, Overheat, Water Contamination, PGM-FI and ACG Warning Systems**

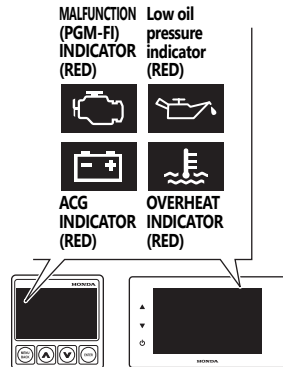

**(Optional equipment: Multi-function Display)**

If the engine oil pressure drops and/ or the engine overheats, either or both warning systems could be activated.

When activated, the engine speed will decrease gradually and the low oil pressure indicator will turn ON and the overheat indicator will turn ON. A continuous buzzer will sound. The engine speed cannot be increased with a larger throttle opening until the malfunction is corrected.

When the malfunction is corrected the engine speed will increase gradually.





If the engine overheats, the engine will stop in 20 seconds after the engine protection system limits engine speed.

Each warning system of PGM-FI, ACG, oil pressure, overheat, and water contamination is activated as described in the following table.

Check the indicators displayed on the multi-function display.

# OPERATION

## Display type

System Symptom	INDICATOR				BUZZER	WARNING LEVEL *1	Power Reduction *2
	low oil pressure indicator (Red)	Overheat (Red)	ACG (Red)	PGM-FI (Red)	CORRESPONDING SYSTEM		
Normal	OFF	OFF	OFF	OFF	OFF	OFF	OFF
Low oil pressure	<b>ON</b>	OFF	OFF	OFF	ON (continuously)	 Warning level 1	ON
Overheat	OFF	<b>ON</b>	OFF	OFF	ON (continuously)	 Warning level 1	ON
ACG warning	OFF	OFF	<b>ON</b>	OFF	Alternating ON and OFF (at long intervals)	 Warning level 2	OFF
PGM-FI warning	OFF	OFF	OFF	<b>ON</b>	Alternating ON and OFF (at long intervals) *3	 Warning level 2	OFF
Water contamination	OFF	OFF	OFF	OFF	Alternating ON and OFF (at short intervals)	 Warning level 2	OFF

Some indicators and/or buzzers may be activated at the same time due to the occurrence of a malfunction.

\*1: Warning level 1 is displayed for errors that require special attention. Warning level 2 is displayed for other errors. For details, refer to the Multi-function Display manual.

\*2: Refer to page 50 about power reduction.

\*3: There are the following two types of buzzer sounds (intermittent long sound) caused by a PGM-FI error.

- If the malfunction (PGM-FI) indicator lights and the buzzer does not stop sounding: Return to port immediately without continuing your voyage. There is a risk of shift operation failure (see page 153), alert detection failure, or engine start failure.
- If the malfunction (PGM-FI) indicator lights and the buzzer sounds for only 10 seconds: Return to port as soon as possible because engine speed control and other functions will be limited.

When the oil pressure warning system is activated:

1. Stop the engine immediately and check the engine oil level (see page 105).
2. If the oil is up to the recommended level, restart the engine. If the oil pressure warning system stops after 30 seconds, the system is normal.

**NOTE:**

If the throttle was closed suddenly after cruising at full throttle, the engine speed may drop below the specified idle speed. This could cause the oil pressure warning system to activate momentarily.

3. If the oil pressure warning system stays activated after 30 seconds, return to the closest boat landing and contact your closest authorized Honda Marine outboard motor dealer.

**COOLING SYSTEM INDICATOR**

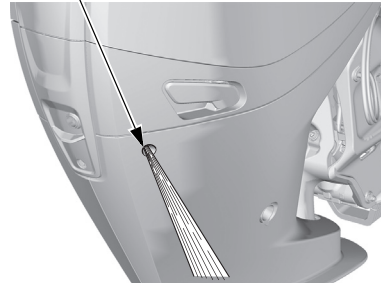

When the overheat warning system is activated:

1. Return the remote control lever to the NEUTRAL position immediately. Check to see if water is flowing out of the cooling system indicator.
2. If water is flowing out of the cooling system indicator, continue idling for 30 seconds. If the overheat warning system stops after 30 seconds the system is normal.

**NOTE:**

If the engine is turned off after running at full throttle, the engine temperature may rise above normal. If the engine is restarted, shortly after being turned off, the overheat warning system could be activated momentarily.

## OPERATION

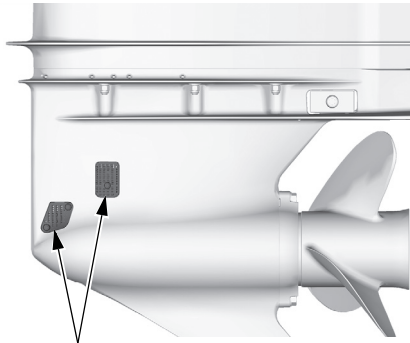

**COOLING WATER INTAKE PORT  
(each side)**

3. If the overheat warning system stays activated, stop the engine. Tilt up the outboard motor and check the water intakes for obstructions. If there are no obstructions at the water intakes, return to the closest boat landing and contact your closest authorized Honda Marine outboard motor dealer.

When the PGM-FI is activated:

1. Consult with an authorized Honda Marine outboard motor dealer.

When the ACG warning system is activated.

1. Check the battery (see page 125).  
If the battery is OK, consult with an authorized Honda Marine outboard motor dealer.

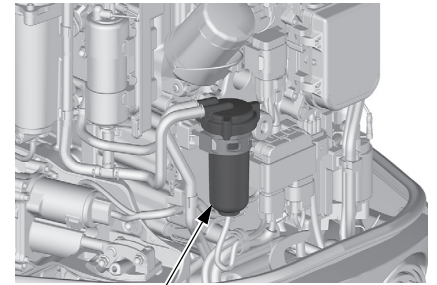

**WATER SEPARATOR**

When the water separator buzzer sounds:

1. Check the water separator for water contamination. If water has accumulated, clean it out (see page 118).

# SERVICING YOUR OUTBOARD MOTOR

## THE IMPORTANCE OF MAINTENANCE

Proper maintenance is essential for safe, economical, and trouble-free operation. It will also help reduce air pollution.

### **▲ WARNING**

Failure to properly maintain this outboard motor, or failing to correct a problem before operation, could result in a significant malfunction.

Some malfunctions can cause serious injuries or death.

Always follow the inspection and maintenance recommendations and schedules in this owner's manual.

To help you properly care for your outboard motor, the following pages include a maintenance schedule, routine inspection procedures, and simple maintenance procedures using basic hand tools. Other service tasks that are more difficult or require special tools are best handled by professionals and are normally performed by a Honda technician or other qualified mechanic.

The maintenance schedule applies to normal operating conditions. If you operate your outboard motor under unusual conditions, consult an authorized Honda Marine outboard motor dealer for recommendations applicable to your individual needs and use.

Remember that your authorized Honda Marine outboard motor dealer knows your outboard motor best and is fully equipped to maintain and repair it.

To ensure the best quality and reliability, use only new, Honda Genuine parts or their equivalents for repair and replacement.

**For US, Puerto Rico, and US Virgin Islands  
Maintenance, replacement, or repair of the emission control devices and systems may be performed by any marine engine repair establishment or individual, using parts that are "certified" to EPA standards.**

# SERVICING YOUR OUTBOARD MOTOR

## MAINTENANCE SAFETY

Some of the most important safety precautions follow. However, we cannot warn you of every conceivable hazard that can arise in performing maintenance. Only you can decide whether or not you should perform a given task.

### **▲ WARNING**

Improper maintenance can cause an unsafe condition.

Failure to properly follow maintenance instructions and precautions can cause serious injuries or death.

Always follow the procedures and precautions in this owner's manual.

## Safety Precautions

- Make sure the engine is off before you begin any maintenance or repairs. This will eliminate several potential hazards:
  - **Carbon monoxide poisoning from engine exhaust.**  
Do not start or run the engine in a confined or partly enclosed area.
  - **Burns from hot parts.**  
Let the engine and exhaust system cool before touching them.
  - **Injury from moving parts.**  
Do not run the engine unless instructed to do so.
- Read the instructions before you begin, and make sure you have the tools and skills required.
- To reduce the possibility of fire or explosion, be careful when working around gasoline. Use only a nonflammable solvent, not gasoline, to clean parts. Keep cigarettes, sparks, and flames away from all fuel-related parts.
- Wear gloves when handling the propeller to protect your hands from sharp edges.
- If the engine must be run, make sure there is water at least 100 mm (4 in) above the anti-cavitation plate, otherwise the water pump may not receive sufficient cooling water, and the engine will overheat.
- Use only Honda Genuine parts or their equivalents for maintenance or repair. The use of replacement parts which are not of equivalent quality may damage the outboard motor.

# SERVICING YOUR OUTBOARD MOTOR

## TOOL KIT and OWNER'S MANUAL

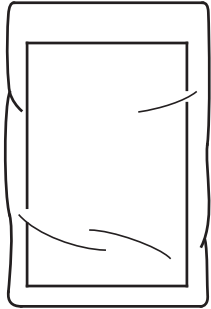

**OWNER'S MANUAL**

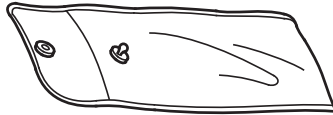

**TOOL BAG**



**10 mm BOX WRENCH**



**6 mm HEX. WRENCH**



**PHILLIPS SCREWDRIVER**

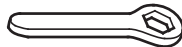

**EYE WRENCH**



**GRIP**

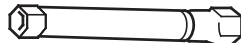

**SPARK PLUG WRENCH**

The tool kit can be used for simple maintenance procedures and emergency repairs. Keep these items on the boat so that they will always be available if you need them.

If your tool kit needs replacement, it is not available as a kit and each item must be ordered individually.

# SERVICING YOUR OUTBOARD MOTOR

---

## SPARE EMERGENCY STOP SWITCH CLIP (optional equipment)

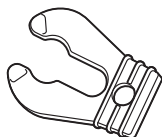

Always carry a spare emergency stop switch clip onboard. The spare clip may either be stored in the tool bag or near the controls in case the operator and primary switch clip falls overboard and a passenger needs to pilot the boat during an emergency situation.

## MAINTENANCE SCHEDULE

Follow the MAINTENANCE SCHEDULE table and service your outboard motor accordingly. As the outboard motor owner, you are responsible for completing all required maintenance listed in your owner's manual. Honda recommends that you retain all receipts covering maintenance on your outboard motor.

Refer to the applicable Distributor's Warranty information for your country or region to understand the full terms and conditions, and how failure to maintain your outboard may affect your warranty coverage. In certain countries and regions, Honda cannot deny warranty coverage solely because of a lack of receipts or your failure to ensure that all scheduled maintenance has been completed.

- For Europe (page 164)
- For US, Puerto Rico, US Virgin Islands and Canada (page 173)

# SERVICING YOUR OUTBOARD MOTOR

REGULAR SERVICE PERIOD (3) Perform at every indicated month or operating hour interval, whichever comes first.		Each use	After use	First month or 20 hrs.	Every 6 months or 100 hrs.	Every year or 200 hrs.	Every 2 years or 400 hrs.	Every 6 years or 1,200 hrs.	Refer to page
ITEM									
Engine oil	Check level	o							105
	Change			o	o				108
Engine oil filter	Replace					o (2)			—
Gear case oil	Change			o (2)	o (2)				—
Timing belt	Check-adjust					o (2)			—
ACG belt	Check-adjust					o (2)			—
Valve clearance	Check-adjust						o (2)		—
Spark plug (Iridium)	Check					o (9)			112 - 115
Spark plug (nickel) (Optional part)	Check-adjust/ Replace				o				115
Propeller and cotter pin	Check	o				o			123
Anode metal (Outside engine) (6)	Stern bracket, Gear case	Check	o			o			122
	Water front screen	Check					o		
	Anode metal (Inside engine) (6)	Check					o (2)		—
	Replace							o (2)	—
Idle speed	Check-adjust			o (2)	o (2)				—
Lubrication	Grease			o (1)	o (1)				109
Fuel filter with water separator (Low pressure side)	Check	o			o				119
	Replace						o		120

- (1) Lubricate more frequently when used in salt water.
- (2) These items should be serviced by your servicing dealer, unless you have the proper tools and are mechanically proficient. Refer to the Honda Shop Manual for service procedures. See "Honda Publications" on P.173 for ordering information.
- (3) For professional commercial use, log hours of operation to determine proper maintenance intervals.
- (6) Replace the anodes when they have been reduced to about two-thirds of their original size, or if they are crumbling.
- (9) Do not clean the spark plugs. If an electrode is contaminated with accumulated objects or dirt, replace the spark plug with a new one. Do not adjust the spark plug gap. If the gap is out of specification, replace the spark plug with a new one.

# SERVICING YOUR OUTBOARD MOTOR

ITEM	REGULAR SERVICE PERIOD (3) Perform at every indicated month or operating hour interval, whichever comes first.	Each use	After use	First month or 20 hrs.	Every 6 months or 100 hrs.	Every year or 200 hrs.	Every 2 years or 400 hrs.	Every 6 years or 1,200 hrs.	Refer to page
Fuel filter (High pressure side)	Replace						o (2)		—
Thermostat and thermostat cover	Check/Replace					o (2)			—
Fuel line	Check	o (7)							61
	Replace		Every 2 years (if necessary) (2) (8)						
Battery and cable connection	Check level-tightness	o							61
Bolts and nuts	Check-tightness			o (2)	o (2)				—
Crankcase breather tube	Check					o (2)			—
Cooling water passages	Clean		o (4)		o (4)				127
Cooling water leak	Check	o							61
Water pump, Woodruff key	Check					o (2)			—
Impeller housing	Check					o (2)			—
Emergency stop switch	Check	o							61
Engine oil leak	Check	o							—
Each operating part	Check	o							—
Engine condition (5)	Check	o							—
Power Trim/Tilt	Check				o (2)				—

- (2) These items should be serviced by your servicing dealer, unless you have the proper tools and are mechanically proficient. Refer to the Honda Shop Manual for service procedures. See "Honda Publications" on P.173 for ordering information.
- (3) For professional commercial use, log hours of operation to determine proper maintenance intervals.
- (4) When operating in salt water, turbid or muddy water, the engine should be flushed with clean water after each use.
- (5) Upon starting, check for unusual engine sounds and cooling water flowing freely from the check hole.
- (7) Check the fuel line for leaks, cracks, or damage. If it is leaking, cracked, or damaged, take it to your servicing dealer for replacement before using your outboard motor.
- (8) Replace the fuel line if there are signs of leaks, cracks, or damage.

## ENGINE COVER REMOVAL AND INSTALLATION

Tilt up the outboard motor as necessary while removing or installing the engine cover.

### Removal

Front

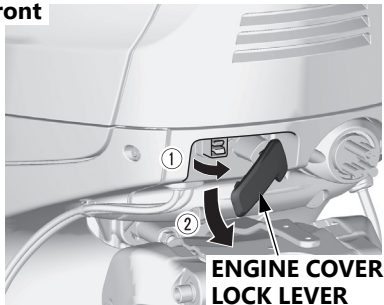

Side

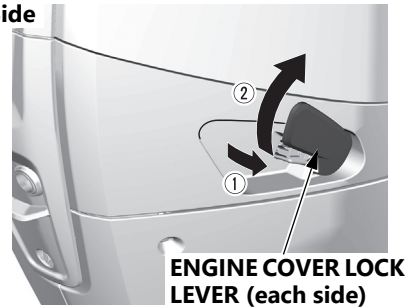

1. Unlock the engine cover.
  - ① Pull out the engine cover lock lever.
  - ② Turn the lever in the direction of the arrow.
2. Remove the engine cover by lifting it straight up from the outboard motor.

# SERVICING YOUR OUTBOARD MOTOR

## Installation

Front

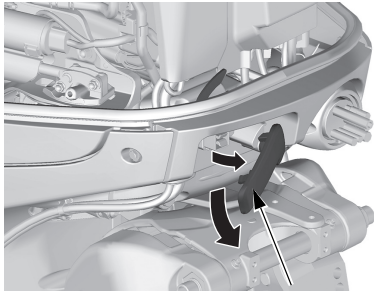

**ENGINE COVER LOCK LEVER**

Side

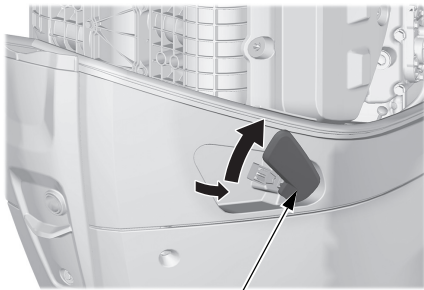

**ENGINE COVER LOCK LEVER (each side)**

1. Rotate and hold the levers as shown.

Side

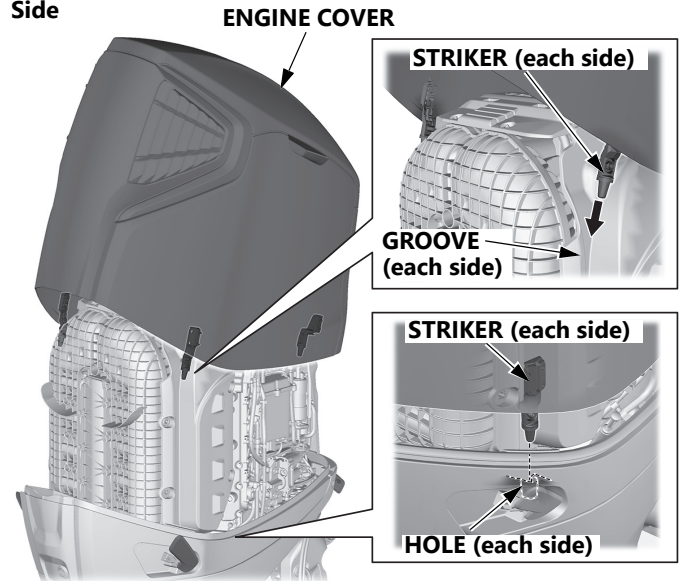

2. Slide the strikers on the engine cover into the grooves on the rear striker cover. Align the strikers on the engine cover with the holes on the main body to install the engine cover.

# SERVICING YOUR OUTBOARD MOTOR

Front

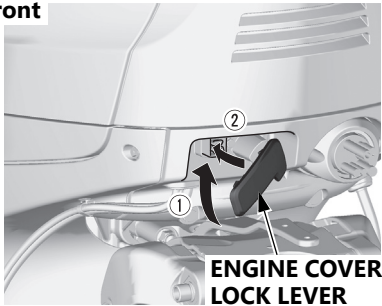

Side

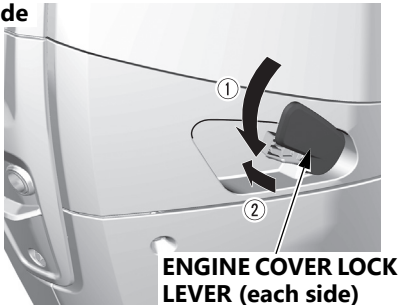

3. Push the engine cover until it is fully seated.

4. Lock the engine cover.

- ① Turn the engine cover lock lever in the direction of the arrow.
  - ② Push in the lever.
5. Check that the engine cover is securely installed.

Lubricate the tip of the striker with silicone spray to make installation easier.

The cover should be tight when fully seated position. If the cover is loose or difficult to secure, an adjustment may be necessary. Please see the shop manual or your marine outboard motor dealer for adjustment.

## ⚠ WARNING

Do not operate the outboard motor without the engine cover. Exposed moving parts can cause injury.

## ⚠ CAUTION

If the engine cover is not installed correctly, water may enter the engine cover and damage the engine. In addition, the engine cover may blow off when cruising at high speeds.

## ENGINE OIL LEVEL CHECK

Check the engine oil level with the engine stopped and the outboard motor in the vertical position.

1. Unlock and remove the engine cover (P.103).
2. Remove the oil level dipstick by pulling it. Wipe the oil level dipstick clean.

# SERVICING YOUR OUTBOARD MOTOR

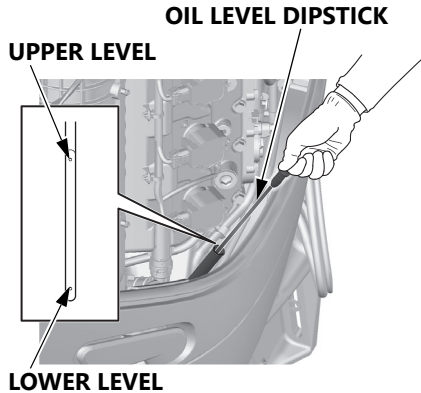

3. Insert the dipstick all the way in, then remove it and check the oil level shown on the dipstick.
4. If the oil level is near or below the lower level mark on the dipstick, remove the front striker guide cover (P.119).

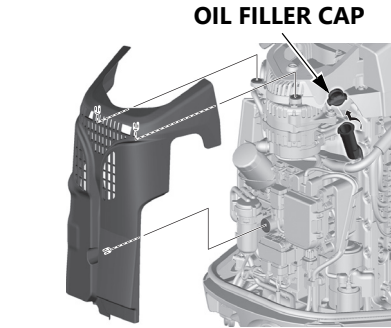

5. Remove the oil filler cap, and add oil so that it reaches the upper level mark shown on the dipstick. Use the oil recommended on P.109.

## NOTICE

- **Running the engine with a low oil level can cause engine damage.**
- **Do not overfill. Overfilling the engine will cause it to smoke or have oil leaks.**

6. Insert the dipstick all the way in. Install the oil filler cap and tighten it securely. Do not overtighten.
7. Install the front striker guide cover in the reverse order of removal.
8. Install and lock the engine cover.

## NOTE:

Please dispose of used outboard motor oil in a manner that is compatible with the environment. We suggest you take it in a sealed container to your local service station or recycling center for reclamation. Do not throw it in the trash or pour it on the ground or down a drain.

Wash your hands with soap and water after handling used oil.

## SERVICING YOUR OUTBOARD MOTOR

When you check the oil level with the dipstick, you might notice the engine oil appears milky or the oil level has increased. If you notice either condition, change the engine oil. See the following table for an explanation of these conditions.

Operating Method	Result	Effect
Running the engine below 3,000 min <sup>-1</sup> (rpm) for more than 30% of the time so the engine does not warm-up.	<ul style="list-style-type: none"><li>• Water condenses in the engine and mixes with the oil, resulting in a milky appearance.</li><li>• Unburned fuel mixes with the oil, increasing the volume of oil.</li></ul>	The engine oil deteriorates, becomes less efficient as a lubricant, and causes an engine malfunction.
Frequent starting and stopping without allowing the engine to warm-up.		

# SERVICING YOUR OUTBOARD MOTOR

## ENGINE OIL CHANGE

An engine oil evacuation/filling device may be used to remove/add the engine oil.

### ⚠ CAUTION

Immediately after the engine has been stopped, the temperature of the engine itself and the oil temperature is high, which may cause burns. Wait until the engine has cooled down before replacing the oil.

Drain the used oil while the engine is warm. Warm oil drains quickly and completely.

1. Unlock and remove the engine cover (P.103).
2. Remove the front striker guide cover (P.119).

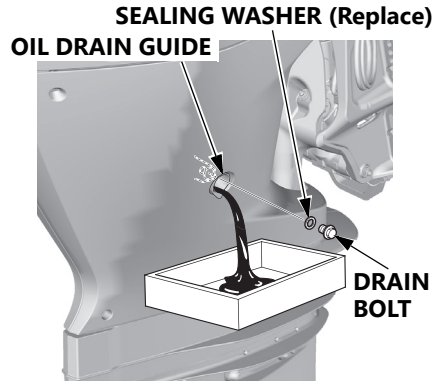

3. Place a suitable container below the oil drain guide to catch the used oil, and then remove the oil filler cap, drain bolt, and sealing washer.
4. Allow the used oil to drain completely. Use a new sealing washer, and then reinstall the engine oil drain bolt using a new washer. Tighten the drain bolt securely.

TIGHTENING TORQUE:  
23 N·m (2.3 kgf·m, 17 lbf·ft)

### NOTICE

- **Improper disposal of engine oil can be harmful to the environment. If you change your own oil, please dispose of the used oil properly. Put it in a sealed container, and take it to a recycling center. Do not throw it in the trash, pour it on the ground or down a drain.**

5. With the outboard motor in a vertical position, fill to the upper level mark on the dipstick (P.105) with the recommended oil. Engine oil refill capacity:  
10.2 L (10.8 US qt, 9.0 Imp qt)
6. Install the oil filler cap and tighten it securely.
7. Install the front striker guide cover in the reverse order of removal.
8. Install and lock the engine cover (P.104).

### NOTICE

- **Always check the amount of oil after filling to avoid overfilling. Too little or too much oil can cause engine damage.**

# SERVICING YOUR OUTBOARD MOTOR

## ENGINE OIL RECOMMENDATIONS

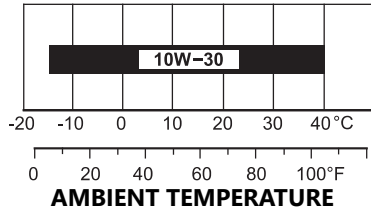

### For US, Puerto Rico, US Virgin Islands and Canada

Oil is a major factor affecting performance and service life. Use 4-stroke detergent oil.

Honda 10W-30 FC-W<sup>®</sup> outboard motor oil is recommended for general use.

FC-W<sup>®</sup> is a registered trademark of the National Marine Manufacturers Association.

If Honda 10W-30 FC-W oil is not available, Honda recommends that you use API service category SG, SH, SJ or SL oil. The SAE oil viscosity and service category are in the API label on the oil container.

### For Europe

Use Honda 4-stroke oil or an equivalent high detergent, premium quality motor oil certified to meet or exceed U.S. automobile manufacturer's requirements for API Service category SG, SH, SJ or SL. Motor oils classified SG, SH, SJ or SL will show this designation on the container. SAE 10W-30 is recommended for general use.

## LUBRICATION POINTS

Apply Honda Marine waterproof grease to the parts shown below:

### NOTICE

- **Apply anticorrosion oil to pivot surfaces where grease cannot penetrate.**
- **Lubricate more frequently when used in salt water.**

Apply Honda Marine Corrosion Inhibitor (or equivalent) to all areas under the engine cover and any exposed metal surfaces except the belts.

# SERVICING YOUR OUTBOARD MOTOR

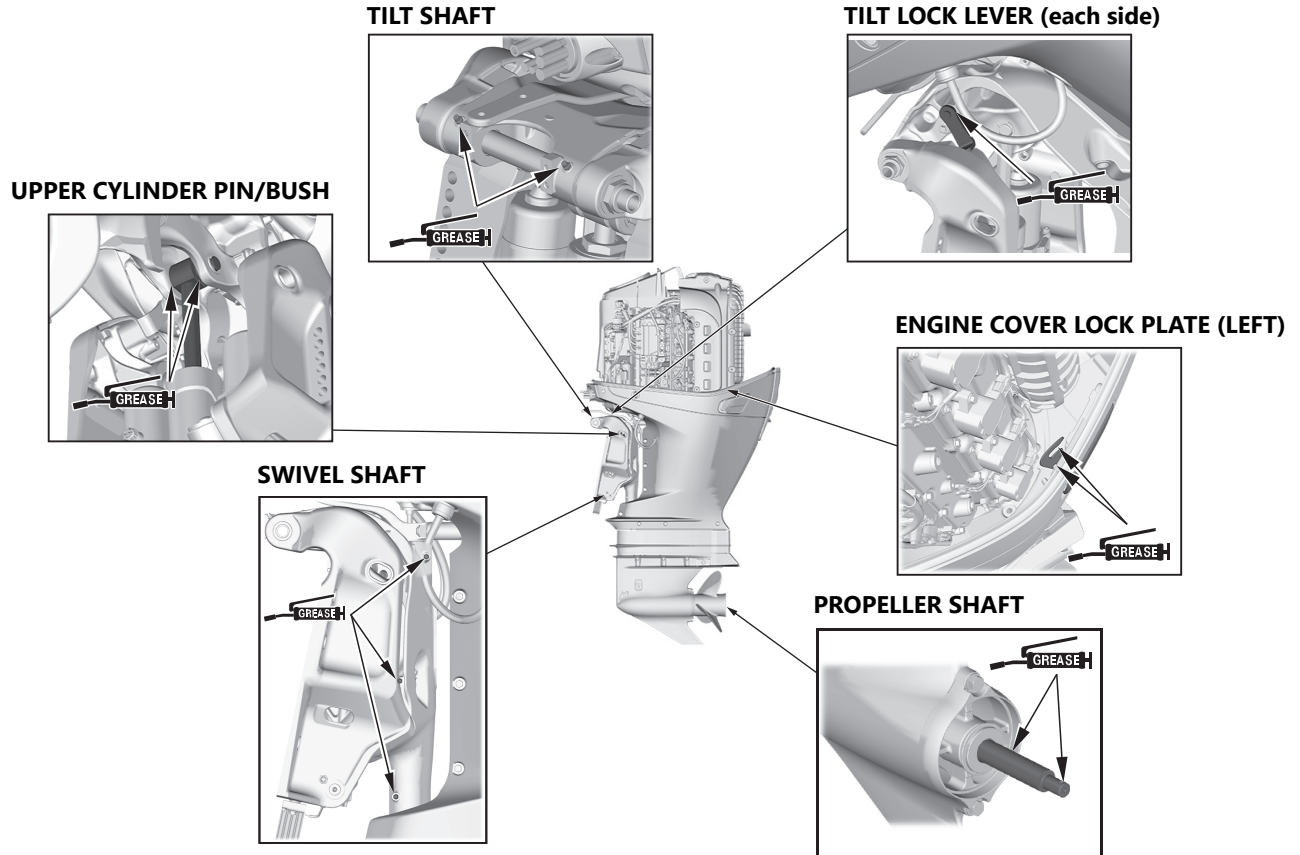

# SERVICING YOUR OUTBOARD MOTOR

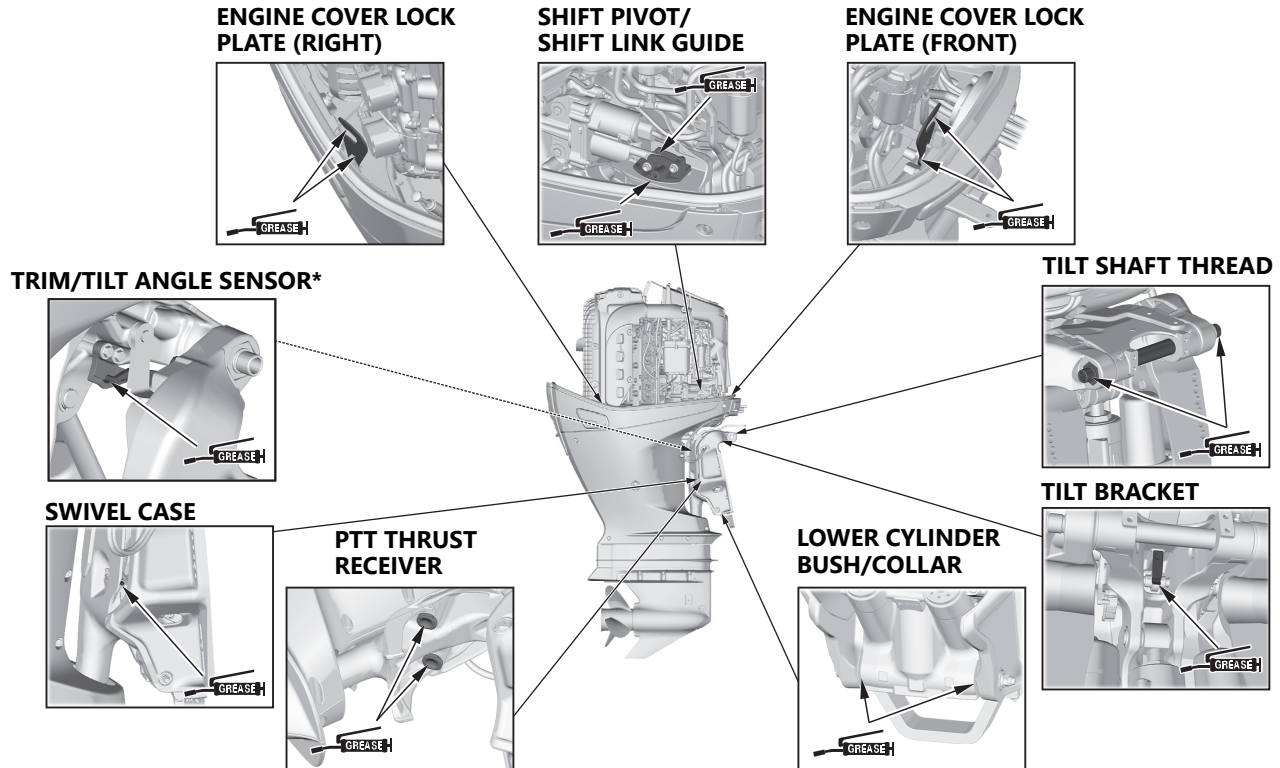

\* Also apply grease to the rail part where the trim/tilt angle sensor arm moves.

# SERVICING YOUR OUTBOARD MOTOR

## SPARK PLUG SERVICE

### ⚠ CAUTION

The spark plugs become very hot during operation and will remain hot for a while after stopping the engine. Allow the engine to cool before servicing the spark plugs.

### NOTICE

- **As the voltage required by a spark plug that is approaching the end of its life increases, it puts a strain on the ignition coil and other parts, which in turn affects engine performance. Spark plugs should be inspected and replaced correctly according to the maintenance schedule.**

## Standard Spark Plug (Iridium)

RECOMMENDED SPARK PLUGS:  
ILZKAR7S11E (NGK)

### NOTICE

- **Incorrect spark plugs can cause engine damage.**

### Inspection and Replacement

1. Disconnect the battery negative (-) terminal.
2. Unlock and remove the engine cover (P.103).

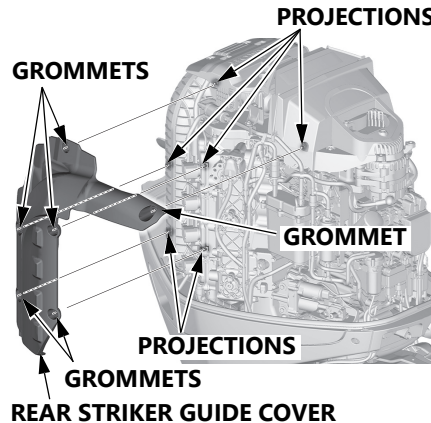

3. Release the grommets on the rear striker guide cover from the projections and remove the rear striker guide cover.

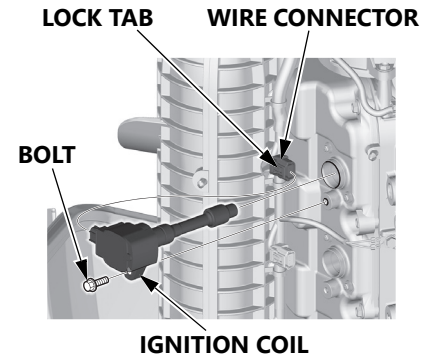

4. Remove the bolt from the ignition coil. Rotate the ignition coil to a position that allows easy removal of the wire connector.
5. Disconnect the wire connector from the ignition coil by pushing on the lock tab and pulling on the connector. Pull

## SERVICING YOUR OUTBOARD MOTOR

on the plastic connector, not the wires.

6. Remove the ignition coil by pulling it up slightly.

### NOTICE

- **Do not strike or drop the ignition coil, or it may be damaged and require replacement.**

SPARK PLUG WRENCH

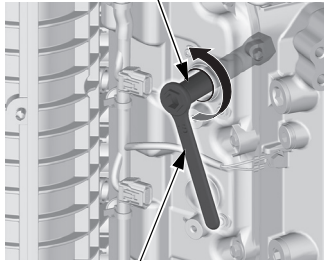

EYE WRENCH

7. Remove the spark plugs with a spark plug wrench and eye wrench.

New plug

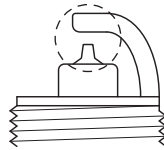

Plug needing replacement

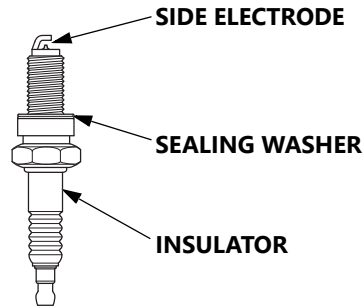
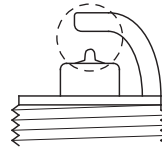

8. Inspect the spark plugs.
  1. If the electrodes are heavily corroded or carbon-soiled, replace the spark plug with a new one.

2. Replace a spark plug if the center electrode is worn. The spark plug can wear out in different ways. If the sealing washer shows signs of wear, or if the insulators are cracked or chipped, replace the spark plug.

## SERVICING YOUR OUTBOARD MOTOR

**SIDE ELECTRODE**

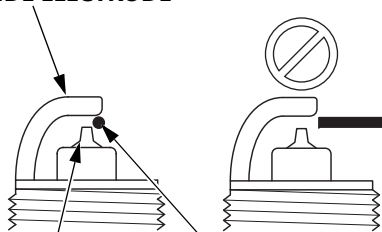

**WIRE TYPE  
PLUG GAUGE**

**CENTER ELECTRODE**

Use a wire type plug gauge to measure the gap (spark gap) between the center electrode and the side electrode.

- Use a wire-type plug gauge to prevent damage to the iridium center electrode.

Check that the  $\Phi 1.3$  mm ( $\Phi 0.051$  in) plug gauge does not fit into the gap.

The gap should be 1.0 – 1.3 mm (0.039 – 0.051 in).

9. These spark plugs have an iridium coated center electrode. Be sure to observe the following when servicing iridium spark plugs.

- Do not clean the spark plugs. If an electrode is contaminated with accumulated material or dirt, replace the spark plug with a new one.
- Use only a “wire-type feeler gauge” to check the spark plug gap if necessary. To prevent damaging the iridium coating of the center electrode, never use a “leaf-type feeler gauge.”

- Do not adjust the spark plug gap. If the gap is out of specification, replace the spark plug with a new one.
10. Install the spark plugs carefully, by hand, to avoid cross-threading.

## SERVICING YOUR OUTBOARD MOTOR

11. After each spark plug is seated, tighten it with the spark plug wrench supplied in the tool kit to compress the sealing washer.

TIGHTENING TORQUE:  
22 N·m (2.2 kgf·m, 16 lbf·ft)

If you do not have a torque wrench, tighten as follows:  
If reinstalling used spark plugs, tighten 1/8 – 1/4 turn after the spark plugs are seated.  
If installing new spark plugs, tighten 1/2 turn after the spark plugs are seated.

### NOTICE

- **Loose spark plugs can overheat and damage the engine.**  
**Overtightening the spark plugs can damage the threads in the cylinder head.**

12. Push the wire connector onto the ignition coil. Make sure it locks in place.
13. Install the ignition coil. Reinstall the bolt.

TIGHTENING TORQUE:  
9.8 – 14 N·m (1.0 – 1.4 kgf·m,  
7.2 – 10 lbf·ft)

14. Repeat this procedure for the other seven spark plugs.
15. Reinstall the covers. When reinstalling the covers, make sure not to pinch the wire harnesses between the covers and engine case.

### Optional Spark Plug (Nickel)

RECOMMENDED SPARK PLUGS:  
LZKAR7F11E (NGK)

### NOTICE

- **Incorrect spark plugs can cause engine damage.**

### Inspection and Cleaning

Installation and removal procedure of the optional spark plugs are the same as the standard spark plugs.

### SIDE ELECTRODE

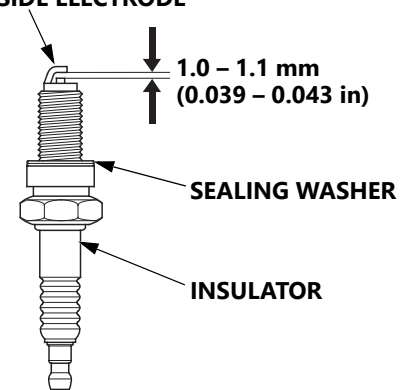

## SERVICING YOUR OUTBOARD MOTOR

Measure the spark plug electrode gap with a feeler gauge. Correct the gap, if necessary, by carefully bending the side electrode.

The gap should be:

1.0 – 1.1 mm (0.039 – 0.043 in)

### ***Replacement***

Replacement procedure of the optional spark plugs are the same as the standard spark plugs.

### **REFUELING**

If you do not anticipate cycling through at least one complete tank of fuel within a 30 day period, we recommend adding Honda Marine Fuel Stabilizer each time you refuel.

Check the fuel level and refill it if necessary. Do not fill the fuel tank above the UPPER LIMIT. Refer to the boat manufacturer's instructions.

### **⚠ WARNING**

Gasoline is highly flammable and explosive.

You can be burned or seriously injured when handling fuel.

- Stop the engine and let it cool before handling fuel.
- Keep heat, sparks, and flame away.
- Handle fuel only outdoors.
- Keep away from your vehicle.
- Wipe up spills immediately.

# SERVICING YOUR OUTBOARD MOTOR

Never refill the fuel tank inside a building where gasoline fumes may reach flames or sparks. Keep gasoline away from appliance pilot lights, barbecues, electric appliances, power tools, etc.

Spilled fuel is not only a fire hazard, it also causes environmental damage. Wipe up spills immediately.

## NOTICE

- **Fuel can damage paint and plastic. Be careful not to spill fuel when filling your fuel tank. Damage caused by spilled fuel is not covered under the warranty.**

## FUEL RECOMMENDATIONS

**Use unleaded gasoline with a Research Octane Number of 91 or higher (a Pump Octane Number of 86 or higher).**

\* Pump Octane Number is used in North America mainly.

Your outboard motor is certified to operate on unleaded gasoline. Unleaded gasoline produces fewer engine and spark plug deposits and extends exhaust system life.

Never use gasoline that is stale, contaminated, or mixed with oil. Avoid getting dirt or water in the fuel tank.

You may use unleaded gasoline containing no more than 10% ethanol (E10) or 5% methanol by volume. In addition, methanol

must contain cosolvents and corrosion inhibitors.

Use of fuels with content of ethanol or methanol greater than shown above may cause starting and/or performance problems. It may also damage metal, rubber, and plastic parts of the fuel system.

Engine damage or performance problems that result from using a fuel with percentages of ethanol or methanol greater than shown above are not covered under warranty.

If your outboard motor will be used on an infrequent or intermittent basis, please refer to the fuel section of the STORAGE chapter (P.130) for additional information regarding fuel deterioration.

# SERVICING YOUR OUTBOARD MOTOR

## GASOLINE CONTAINING ALCOHOL

If you decide to use a gasoline containing alcohol (gasohol), be sure its octane rating is at least as high as that recommended by Honda. There are two types of "gasohol": one containing ethanol, and the other containing methanol.

Do not use gasohol that contains more than 10% ethanol.

Do not use gasoline containing more than 5% methanol (methyl or wood alcohol) and that does not also contain co-solvents and corrosion inhibitors for methanol.

## FUEL FILTER WITH WATER SEPARATOR (LOW PRESSURE SIDE) INSPECTION AND REPLACEMENT

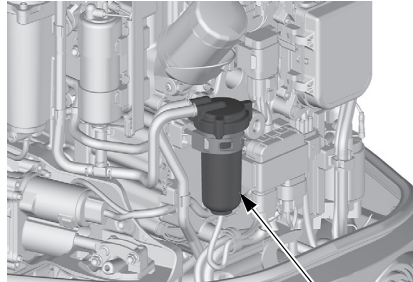

**FUEL FILTER with WATER SEPARATOR (LOW PRESSURE SIDE)**

The fuel filter with water separator is located below the intake manifold.

Water or sediment accumulation in the fuel filter with water separator can cause loss of power or difficult starting.

To prevent engine malfunction, inspect the fuel filter with water separator and replace it when necessary.

Clean the filter or consult with an authorized Honda Marine outboard motor dealer for cleaning.

### **⚠ WARNING**

Gasoline is highly flammable and explosive.

You can be burned or seriously injured when handling fuel.

- Stop the engine and let it cool before handling fuel.
- Keep heat, sparks, and flame away.
- Handle fuel only outdoors.
- Keep away from your vehicle.
- Wipe up spills immediately.

# SERVICING YOUR OUTBOARD MOTOR

## Inspection

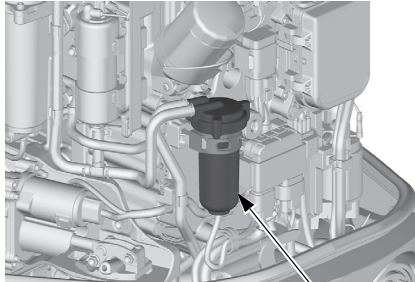

**FUEL FILTER with WATER SEPARATOR  
(LOW PRESSURE SIDE)**

1. Remove the engine cover (P.103).

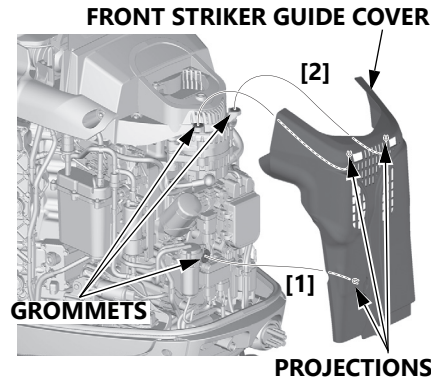

2. Release the projection of the front striker guide cover lower side from the grommet, and then release the projections of the front striker guide cover upper side from the grommets. Remove the front striker guide cover.

3. Looking through the translucent strainer cup, check for accumulation of water or sediment.

If the fuel filter with water separator is clogged, refer to fuel filter with water separator replacement procedure (P.120) to remove the filter and clean it.

If water is present in the fuel filter with water separator, refer to fuel filter with water separator replacement procedure to remove the strainer cup and empty the water from the inside of the cup.

# SERVICING YOUR OUTBOARD MOTOR

## Replacement

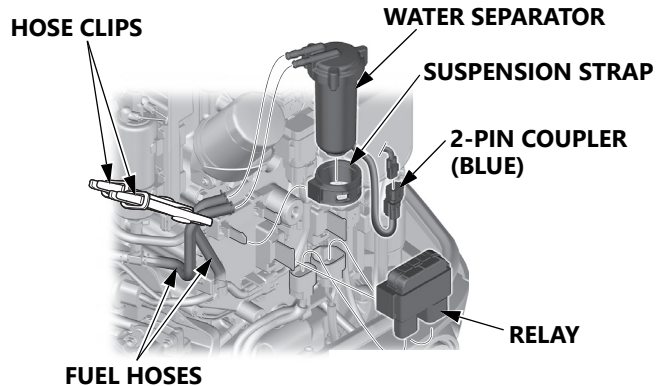

1. Remove the engine cover (P.103).
2. Remove the front striker guide cover (P.119).
3. Remove the relay.
4. Disconnect the 2-pin coupler (blue).
5. Remove the suspension strap from the fuel filter with water separator bracket, then remove the suspension strap from the fuel filter with water separator.
6. Bind the two fuel tubes with the tube clips to prevent fuel leakage, disconnect the fuel tubes.

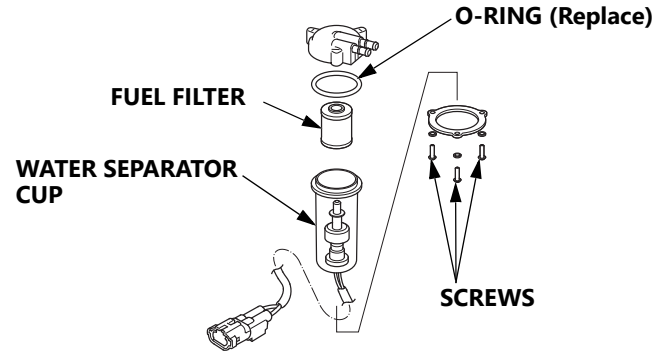

7. Remove the three screws holding the fuel filter with water separator, empty the water or deposits from the inside of the cup.
8. Thoroughly clean the cup. If the fuel filter is clogged, or has reached the end of its replacement period, replace it with a new one.
9. Reassemble the fuel filter with water separator in the reverse order of removal. Use a new O-ring.

### TIGHTENING TORQUE:

3.4 N·m (0.34 kgf·m, 2.5 lbf·ft)

## SERVICING YOUR OUTBOARD MOTOR

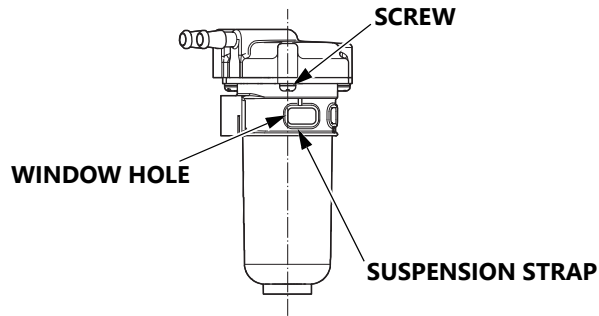

Clean the fuel tank and tank filter if necessary. The fuel tank may need to be drained completely and refilled with fresh gasoline.

10. When installing the suspension strap to the fuel filter with water separator, align the left end of the suspension strap window hole with the screw as shown in the figure.
11. Prime the engine using the priming bulb (P.63). Check for fuel leaks. Repair any fuel leaks if necessary.

If the buzzer sounds or water or sediment accumulation is found in the fuel filter with water separator, inspect the fuel tank.

# SERVICING YOUR OUTBOARD MOTOR

## ANODE INSPECTION

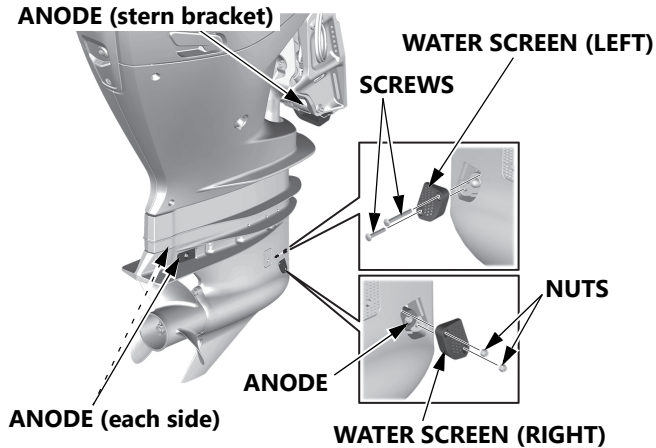

The anodes are located on each side of the gear case, on the right cooling water intake port and on the stern bracket. They are made of a sacrificial material that helps to protect the outboard motor from corrosion.

Replace the anodes when they have been reduced to about two-thirds of their original size, or if they are crumbling.

## Water Screen Removal/Installation

1. Loosen the screws and remove the nuts.
2. Remove the water screen (right).
3. Remove the water screen (left).  
If the water inlet is clogged with waterweed or mud, remove it.
4. Install the nuts and water screen (right) to the gear case by holding the nuts.
5. Install the screws and water screen (left).
6. Be careful not to drop the nuts as you tighten the screws.

### TIGHTENING TORQUE:

1.0 N·m (0.1 kgf·m, 0.7 lbf·ft)

# SERVICING YOUR OUTBOARD MOTOR

## PROPELLER REPLACEMENT

Before replacing the propeller, remove the emergency stop switch clip from the emergency stop switch to prevent any possibility of the engine being started while you are working with the propeller.

The propeller blades may have sharp edges, so wear heavy gloves to protect your hands.

Operating the outboard motor at higher altitudes will reduce available power. This may require decreasing the propeller pitch to maintain correct engine RPM.

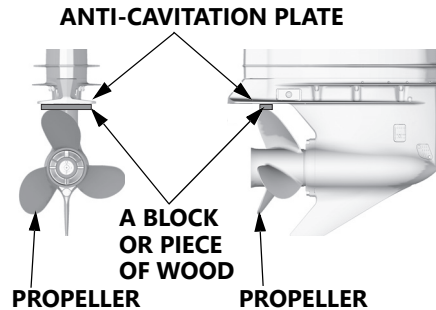

When replacing the propeller, put a suitable block or piece of wood between the propeller and the anti-cavitation plate to prevent the propeller from rotating.

## Removal

1. Remove the cotter pin, unscrew the castle nut, remove the washer, and then remove the propeller and thrust washer.
2. Inspect the propeller shaft for any fishing line or debris.

## Installation

Some propeller brands require specific mounting hardware. Refer to your specific propeller manufacturer's instructions for proper installation.

1. Apply marine grade grease to the propeller shaft.

## SERVICING YOUR OUTBOARD MOTOR

2. Install the thrust washer with the grooved side toward the gear case.
3. Install the propeller.
4. Install the washer as shown below.
5. Lightly tighten the castle nut by hand or wrench until the propeller has no free play.
6. Tighten the castle nut using a torque wrench.  
TIGHTENING TORQUE:  
56 N·m (5.7 kgf·m, 41 lbf·ft)
7. Then, using a torque wrench, tighten the castle nut until the first available groove in the castle nut aligns with the cotter pin hole. Do not tighten past the first alignment of the castle nut groove and the cotter pin hole.

### NOTICE

- **TIGHTENING TORQUE LIMIT: 128 N·m (13 kgf·m, 94 lbf·ft)**  
**Do not tighten the castle nut above the TIGHTENING TORQUE LIMIT, or the propeller and shaft may be damaged.**

8. Be sure to replace the cotter pin with a new one.
  - Use a Honda Genuine stainless steel cotter pin or equivalent cotter pin to lock the pin in place and bend the pin ends.

Note that the castle nut wrench is not included with the tool set that comes with the outboard motor. Contact your authorized Honda Marine outboard motor dealer for additional tool information.

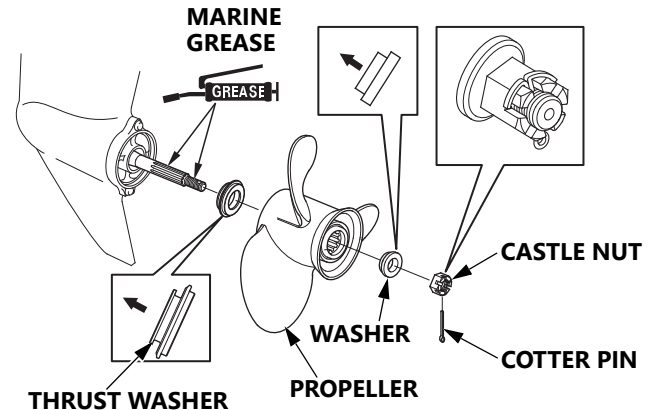

# SERVICING YOUR OUTBOARD MOTOR

## BATTERY

### NOTICE

- **Battery handling differs according to the type of the battery and the instructions described below might not be applicable to the battery of your outboard motor. Refer to the battery manufacturer's instructions.**

### ⚠ WARNING

Batteries produce explosive gases: If ignited, an explosion can cause serious injury or blindness. Provide adequate ventilation when charging.

- **CHEMICAL HAZARD:**  
Battery electrolyte contains sulfuric acid. Contact with eyes or skin, even through clothing, may cause severe burns. Wear a faceshield and protective clothing.
- Keep flames and sparks away, and do not smoke in the area. **ANTIDOTE:** If electrolyte gets into your eyes, flush thoroughly with warm water for at least 15 minutes and call a physician immediately.

- **POISON:** Electrolyte is poison.  
**ANTIDOTE:**
  - External: Flush thoroughly with water.
  - Internal: Drink large quantities of water or milk. Follow with milk of magnesia or vegetable oil, and call a physician immediately.
- **KEEP OUT OF REACH OF CHILDREN.**

Battery posts, terminals, and related accessories contain lead and lead compounds. Wash your hands after handling them.

# SERVICING YOUR OUTBOARD MOTOR

## Battery Cleaning

1. Disconnect the battery cable at the battery negative (-) terminal, then at the battery positive (+) terminal.
2. Remove the battery and clean the battery terminals and battery cable terminals with a wire brush or sand paper. Clean the battery with a solution of baking soda and warm water, taking care not to get the solution or water in the battery cells. Dry the battery thoroughly.

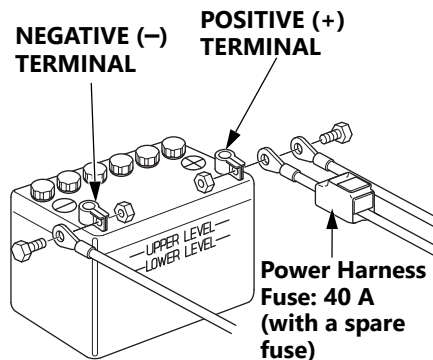

3. Connect the battery positive (+) cable to the battery positive (+) terminal, then the battery negative (-) cable to the battery negative (-) terminal. Tighten the bolts and nuts securely. Coat the battery terminals with grease.

## ⚠ CAUTION

When disconnecting the battery cable, be sure to disconnect at the battery negative (-) terminal first. To connect, connect at the positive (+) terminal first, then at the negative (-) terminal. Never disconnect or connect the battery cables in the opposite order, doing so could result in a short circuit if a tool contacts the terminals.

# CLEANING AND FLUSHING

## CLEANING AND FLUSHING

After each use in salt water or dirty water, thoroughly clean and rinse the outboard motor with fresh water.

Touch up any damaged paint, and coat areas that may rust with Honda Corrosion Inhibitor, or equivalent.

Lubricate controls with a silicone spray lubricant.

### NOTICE

- **Do not apply water or corrosion inhibitor directly to the electrical components under the engine cover, such as the AC generator, O<sub>2</sub> sensor, or the AC generator belt. If water or corrosion inhibitor penetrates these components, they may be damaged. Before applying a corrosion inhibitor, cover the AC generator, belt and O<sub>2</sub> sensor with a protective material to prevent damage.**

## Cleaning

Wash the outside of the outboard motor with clean, fresh water, and flush the cooling system as follows.

Cleaning of the outside of the outboard motor should be performed with the engine cover installed.

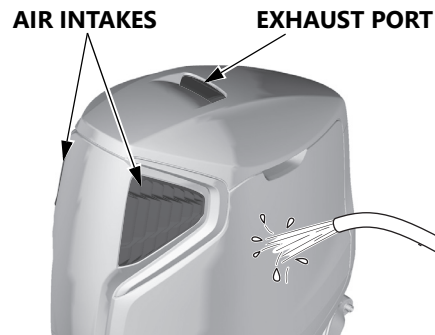

# CLEANING AND FLUSHING

## NOTICE

- Be careful not to spray water into the air intakes and the exhaust port. If water penetrates inside the engine cover from the air intakes and the exhaust port, it may cause malfunction.

## Flushing With a Water Hose (Garden Hose) (commercially available)

### NOTICE

- Do not run the engine when flushing the outboard motor with a water hose (garden hose) or the outboard motor may be damaged.

For safety, remove the emergency stop switch clip so the engine cannot be started while you are standing near the propeller.

1. Tilt down the outboard motor.
2. Clean and wash the outside of the outboard motor with fresh water.

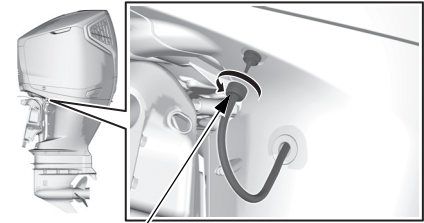

FLUSH PORT CONNECTOR

3. Disconnect the flush port connector.

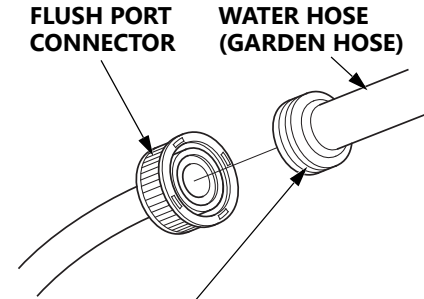

WATER HOSE (GARDEN HOSE) JOINT  
(Commercially available)

4. Screw the flush port connector onto the water hose (garden hose).

**COOLING WATER INTAKE PORT**  
(each side)

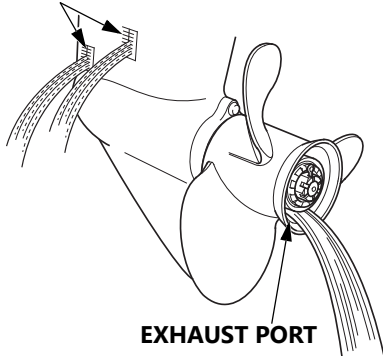

5. Turn on the fresh water supply and flush the outboard motor for at least 10 minutes. Check that water is draining from the cooling system indicator, the cooling water intake port and the exhaust port.

### NOTICE

- **Do not start the engine while flushing, or it may cause malfunction.**
6. After flushing, disconnect the water hose (garden hose) and reconnect the flush port connector.
  7. Tilt up the outboard motor and move the tilt lock levers to the LOCK position (P.40).

# STORAGE

## FUEL

### NOTICE

- **Depending on the region where you operate your outboard, fuel formulations may deteriorate and oxidize rapidly. Fuel deterioration and oxidation can occur in as little as 15 days and may cause damage to the fuel system. Please check with your servicing dealer for local storage recommendations.**

Gasoline will oxidize and deteriorate in storage. Old gasoline will cause hard starting, and it leaves gum deposits that clog the fuel system. If the gasoline in your fuel tank and vapor separator deteriorates during storage, you may need to have the vapor separator and other fuel system components serviced or replaced.

The length of time that gasoline can be left in your fuel tank and vapor separator without causing functional problems will vary with such factors as gasoline blend, your storage temperatures, and whether the fuel tank is partially or completely filled.

The air in a partially filled fuel tank promotes fuel deterioration. Very warm storage temperatures accelerate fuel deterioration. Fuel deterioration problems may occur in less than 15 days, if the gasoline was not fresh when you filled the fuel tank.

You can extend fuel storage life by adding a gasoline stabilizer that is formulated for that purpose, or you can avoid fuel deterioration problems by draining all the fuel from the fuel tank and vapor separator.

The warranty does not cover fuel system damage or engine performance problems resulting from neglected storage preparation. See page 117 for additional information on fuel recommendations.

## Storage Procedure

### ⚠ WARNING

Gasoline is highly flammable and explosive.

You can be burned or seriously injured when handling fuel.

- Stop the engine and let it cool before handling fuel.
- Keep heat, sparks, and flame away.
- Handle fuel only outdoors.
- Keep away from your vehicle.
- Wipe up spills immediately.

1. Remove the engine cover (P.103).
2. Inspect the fuel filter with water separator (low-pressure side). If water has collected inside it or there is a clog, such as sediment in the cup, then remove the water or replace the filter. (P.120)

3. Drain the gasoline from the drain screw of the vapor separator. (P.132)
4. Confirm that there is no water or dirt mixed in with the gasoline that you remove.
5. Do the following operation if you find water or dirt mixed in with the gasoline that you remove.
  - ① Confirm that the drain screw has been tightened.
  - ② Keep the motor level as you connect a fuel tank that has fresh gasoline.
  - ③ Use the primer bulb to supply fresh gasoline to the vapor separator.

### ⚠ CAUTION

Always operate the primer bulb while the drain screw is tight. If the drain screw is loose, then gasoline will leak.

- ④ Start the engine and run it at idle for 1 minute.

### NOTICE

• **Always start the engine under normal operating conditions (while the propeller is in the water). Never start it while the propeller is out of the water. Doing so will damage the engine.**

- ⑤ Drain the gasoline from the drain screw of the vapor separator. (P.132)
- ⑥ Confirm that there is no water or dirt mixed in with the gasoline that you remove.
- ⑦ If you find water or dirt in the gasoline that you remove, then repeat steps ① to ⑥ until you can confirm there is no water or dirt.

## STORAGE

### Adding a Fuel Stabilizer

When adding a fuel stabilizer, fill the fuel tank with fresh gasoline. If only partially filled, air in the tank will promote fuel deterioration during storage. If you keep an additional container of gasoline for refueling, be sure that it contains only fresh gasoline.

1. Drain the vapor separator before adding fuel stabilizer.
2. Add Honda Marine fuel stabilizer or equivalent following the instructions on the label.
3. After adding a fuel stabilizer, run the engine in water for 10 minutes to be sure that the treated gasoline has replaced the untreated gasoline in the vapor separator.
4. Turn the engine OFF.

### Draining the Fuel System

#### **⚠ WARNING**

Gasoline is highly flammable and explosive.

You can be burned or seriously injured when handling fuel.

- Stop the engine and let it cool before handling fuel.
- Keep heat, sparks, and flame away.
- Handle fuel only outdoors.
- Keep away from your vehicle.
- Wipe up spills immediately.

You can avoid fuel deterioration problems by draining the fuel tank and vapor separator.

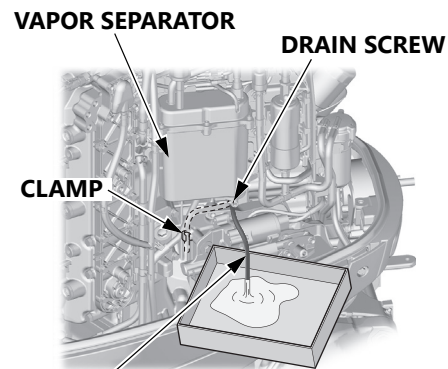

**DRAIN HOSE**  
**(Draining the fuel becomes easier when the front end of the drain hose is as low as possible)**

1. Remove the engine cover (P.103)
2. Disconnect the drain hose of the vapor separator, which is anchored by the clamp on the lower right, and put its end out of the undercase.

3. Place an approved gasoline container below the fuel drain outlet.
4. Loosen the drain screw on the vapor separator.
5. After draining thoroughly, tighten the drain screw securely.

#### TIGHTENING TORQUE:

2.3 N·m (0.23 kgf·m, 1.7 lbf·ft)

6. Reattach the drain hose into the clamp in the reverse order of removal.
7. Drain the fuel tank into an approved gasoline container, or if you need to store fuel in the fuel tank, you can extend fuel storage life by filling the fuel tank with fresh gasoline and adding Honda Marine fuel stabilizer or equivalent following the directions on the container.

## ENGINE OIL

1. Change the engine oil (P.108).
2. Remove the emergency stop switch clip from the emergency stop switch, and remove the spark plugs (P.112).
3. Pour 1 - 2 teaspoons (5 - 10 cm<sup>3</sup>) of clean engine oil into each cylinder.
4. Rotate the engine a few revolutions to distribute the oil in the cylinders.
5. Reinstall the spark plugs (P.112).

## BATTERY STORAGE

### NOTICE

- **Battery handling differs according to the type of the battery and the instructions described below might not be applicable to the battery of your outboard motor. Refer to the battery manufacturer's instructions.**

### ⚠ WARNING

Batteries produce explosive gases: If ignited, an explosion can cause serious injury or blindness. Provide adequate ventilation when charging.

- **CHEMICAL HAZARD:**  
Battery electrolyte contains sulfuric acid. Contact with eyes or skin, even through clothing, may cause severe burns. Wear a faceshield and protective clothing.

## STORAGE

### ⚠ WARNING

- Keep flames and sparks away, and do not smoke in the area.  
ANTIDOTE: If electrolyte gets into your eyes, flush thoroughly with warm water for at least 15 minutes and call a physician immediately.
- POISON: Electrolyte is poison.  
ANTIDOTE  
– External: Flush thoroughly with water.  
– Internal: Drink large quantities of water or milk. Follow with milk of magnesia or vegetable oil, and call a physician immediately.
- KEEP OUT OF REACH OF CHILDREN.

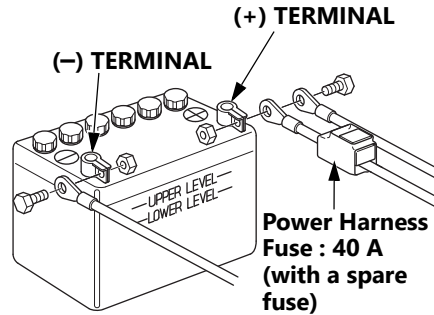

1. Disconnect the battery cable at the battery negative (-) terminal, then at the battery positive (+) terminal.
2. Remove the battery and clean the battery terminals and battery cable terminals with a wire brush or sand paper. Clean the battery with a solution of baking soda and warm water, taking care not to get the solution of water in the battery cells. Dry the battery thoroughly.

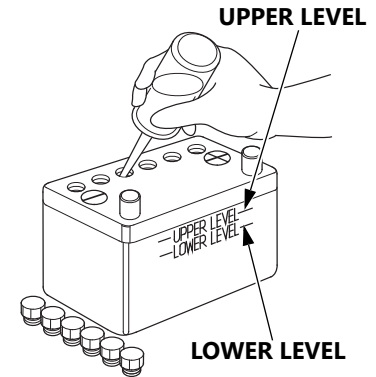

3. Fill the battery with distilled water to the upper level line. Never overfill the battery.
4. Store the battery on a level surface in a cool, dry, well ventilated place out of direct sunlight.
5. Once a month, check the specific gravity of the electrolyte and recharge as required to prolong battery life.

### HOISTING THE OUTBOARD MOTOR

Consult an authorized Honda Marine outboard motor dealer when removing the outboard motor from the hull.

### STORAGE PRECAUTIONS

Select a well-ventilated storage area. If possible, avoid storage areas with high humidity.

If storing a container of gasoline, store it away from any appliance that operates with a flame, such as a furnace, water heater, or clothes dryer. Also avoid any area with a spark producing electric motor, or where power tools are operated.



**OUTBOARD MOTOR STAND**

If the outboard motor will be removed from the boat for storage, store it vertically by mounting it on a commercially available stand.

If the outboard will be stored while installed onto the boat, it is recommended to lower the power tilt/trim down into the normal running position. Otherwise, the hydraulic trim rods can be exposed to foreign debris. If the trim rods remain extended for long-term storage and the tilt lock levers are not engaged, the hydraulic pressure

on the trim rods from the outboard's weight can decrease over time and cause the outboard motor to tilt down. If there is foreign debris on the trim rods, it can damage the power trim/tilt seals and cause an oil leak. If there is insufficient space to store the outboard in the normal running position, always move the tilt lock levers into the LOCK position so that the hydraulic pressure is removed from the trim rods (see page 86).

Cover the outboard motor to keep out dust. Do not use a plastic sheet as a dust cover. A nonporous cover will trap moisture, promoting rust and corrosion.

### REMOVAL FROM STORAGE

Check your outboard motor as described in the *BEFORE OPERATION* chapter of this manual.

If the cylinders were coated with oil during storage preparation, the engine may smoke briefly at startup. This is normal.

# TRANSPORTING

## FUEL LINE DISCONNECTION

Before transporting the outboard motor, disconnect and remove the fuel line.

### **⚠ WARNING**

Gasoline is highly flammable and explosive.

You can be burned or seriously injured when handling fuel.

- Stop the engine and let it cool before handling fuel.
- Keep heat, sparks, and flame away.
- Handle fuel only outdoors.
- Keep away from your vehicle.
- Wipe up spills immediately.

## WITH OUTBOARD MOTOR INSTALLED ON BOAT

Use an outboard motor support bar to prevent the outboard motor from moving while trailering the boat.

Refer to the manufacturer's instructions for using an outboard motor support bar.

The preferred method is to leave the engine in the normal running position, but if there is insufficient road clearance, you can tilt the outboard motor using a commercially available outboard motor support bar available through your dealer. Refer to the manufacturer's instructions for using an outboard motor support bar.



**OUTBOARD MOTOR SUPPORT BAR (commercially available)**

## **WITH OUTBOARD MOTOR REMOVED FROM BOAT**

Secure the outboard motor in the vertical position shown on P.135.

## **DISPOSAL**

To protect the environment, do not dispose of this product, battery, engine oil, etc. carelessly by leaving them in the waste. Observe the local laws and regulations or consult your dealer for disposal.

## TAKING CARE OF UNEXPECTED PROBLEMS

First, do the following inspections yourself. If any troubles remain after that, take the outboard motor to an authorized marine outboard motor dealer. Do not casually disassemble the outboard motor.

### ELECTRIC STARTER WILL NOT OPERATE

Possible Cause	Correction
Battery connections loose or corroded.	Clean and tighten battery connections.
Battery discharged.	Recharge battery.
Fuse(s) blown.	Replace fuse(s) (P.145).
Stuck valves, starter malfunction, switch malfunction, or electrical problem in the starting circuit, etc.	Use starting procedure (P.64) if engine still will not start, then take outboard motor to an authorized marine outboard motor dealer, or refer to the shop manual.

## TAKING CARE OF UNEXPECTED PROBLEMS

---

### ENGINE WILL NOT START

Possible Cause	Correction
Clip not inserted in emergency stop switch.	Insert clip in emergency stop switch.
Control lever not in neutral position.	Shift to neutral.
Out of fuel.	Refuel (P.116).
Fuel hose not primed.	Squeeze priming bulb (P.63).
Fuel filter with water separator or fuel tank filter clogged.	Replace fuel filters (P.120).
Bad fuel, outboard motor stored without treating or draining gasoline, or refueled with bad gasoline.	Drain fuel tank and vapor separator (P.132). Refill with fresh gasoline (P.116).
Water separator full of accumulated water.	Clean water separator (P.119).
Spark plugs faulty, fouled, or improperly gapped.	Gap (non-iridium type) or replace spark plugs (P.112).
Spark plugs wet with fuel (flooded engine).	Dry and reinstall spark plugs. Start engine with the throttle open.
Fuel system malfunction, fuel pump failure, ignition malfunction, etc.	Take outboard motor to an authorized marine outboard motor dealer, or refer to the shop manual.

## TAKING CARE OF UNEXPECTED PROBLEMS

---

### HARD STARTING OR STALLS AFTER STARTING

Possible Cause	Correction
Fuel hose not primed.	Squeeze priming bulb (P.63).
Fuel filter or fuel tank filter clogged.	Replace fuel filters (P.120).
Bad fuel; outboard motor stored without treating or draining gasoline, or refueled with bad fuel.	Drain fuel tank and vapor separator (P.132). Refill with fresh gasoline (P.116).
Water separator full of accumulated water.	Clean water separator (P.118).

## TAKING CARE OF UNEXPECTED PROBLEMS

---

### ENGINE OVERHEATS

Possible Cause	Correction
Water intake screens clogged.	Clean water intake screens (P.122).
Faulty thermostat or water pump.	Take outboard motor to an authorized marine outboard motor dealer, or refer to the shop manual.

## TAKING CARE OF UNEXPECTED PROBLEMS

### WARNING SYSTEM COMES ON

SYMPTOM	POSSIBLE CAUSE	REMEDY
Overheat warning system comes on: <ul style="list-style-type: none"><li>• Overheat indicator comes on.</li><li>• Overheat warning buzzer sounds.</li><li>• Engine speed decreases and stops.</li><li>• Engine speed cannot be increased by opening the throttle.</li><li>• Engine will stop in 20 seconds after engine speed is limited.</li></ul>	Cooling water intake port clogged.	Clean the cooling water intake port.
	Spark plug has improper heat range.	Replace the spark plug (see page 112 – 115).
Oil pressure warning system comes on: <ul style="list-style-type: none"><li>• Low oil pressure indicator comes on.</li><li>• Oil pressure warning buzzer sounds.</li><li>• Engine speed decreases.</li><li>• Engine speed cannot be increased by opening the throttle.</li></ul>	Shortage of engine oil	Add engine oil to the specified level (see page 105).
	Improper engine oil is used.	Change the engine oil (see page 108).

## TAKING CARE OF UNEXPECTED PROBLEMS

SYMPTOM	POSSIBLE CAUSE	REMEDY
Water separator warning system comes on: <ul style="list-style-type: none"> <li>• Water separator warning buzzer sounds.</li> </ul>	Water has accumulated in the water separator.	Clean the water separator (see page 118). Check the fuel tank and fuel line for water accumulation. If the buzzer sounds again, consult with an authorized Honda Marine outboard motor dealer.
Malfunction (PGM-FI) warning system comes on: <ul style="list-style-type: none"> <li>• Malfunction (PGM-FI) indicator comes on.</li> <li>• Malfunction (PGM-FI) warning buzzer sounds intermittently.</li> <li>• Gear does not shift even if the remote control is operated</li> </ul>	Error was detected in the DBW shift system.	Restart the engine. If the problem recurs, consult with an authorized Honda Marine outboard motor dealer.
	Electrical damage or failure of DBW shift actuator.	Shift manually (see page 153). After returning to port, or if the problem persists, consult with an authorized Honda Marine outboard motor dealer.
	Malfunction (PGM-FI) warning system is faulty.  Mechanical damage or failure of DBW shift device.	Consult with an authorized Honda Marine outboard motor dealer.
ACG warning system comes on: <ul style="list-style-type: none"> <li>• ACG indicator comes on.</li> <li>• ACG warning buzzer sounds intermittently.</li> </ul>	Battery voltage is too high or low.	Check the battery (see page 125, 155).
	Faulty ACG.	Consult with an authorized Honda Marine outboard motor dealer.

## TAKING CARE OF UNEXPECTED PROBLEMS

### FUSES

#### Electric Starter Will Not Operate

The 7.5 A, 15 A, and 30 A main fuses protect the electric starter relay and related circuits.

The main fuse protects the ignition switch and related circuits. If this fuse blows, the engine will not start or run, and the power trim/tilt switch will not activate the trim/tilt mechanism.

The 40 A fuse is in the power harness connected to the battery. If this fuse blows, the engine will not start or run.

#### Battery Will Not Charge

A 200 A ACG fuse protects the alternator circuit. If the ACG fuse blows, the engine will not charge the battery. Refer to P.149.

#### Fuse Replacement

##### NOTICE

- **Disconnect the battery cable at the battery negative ( - ) terminal before replacing the fuse.**  
**Failure to do so may cause a short circuit.**

#### Power Harness

##### FUSE HOLDER COVER

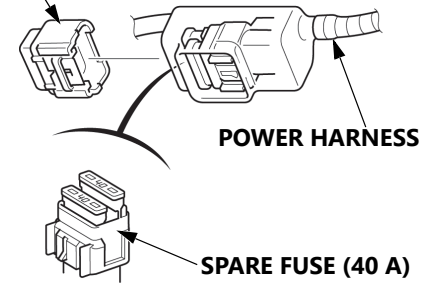

1. Stop the engine.
2. Disconnect the battery cable and the power harness.
3. Open the fuse holder cover.
4. Pull the old fuse out of the clip with the fuse puller supplied in the junction box (P.147).
5. Push a new fuse (40A) into the clip.
6. Close the fuse holder cover.

## TAKING CARE OF UNEXPECTED PROBLEMS

### Main Fuse

A spare fuse is located on the reverse side of the junction box lid.

1. Stop the engine and disconnect the battery cable.
2. Remove the engine cover. (P.103)
3. Remove the front striker guide cover (P.119).
4. Open the junction box lid.

### SPARE FUSES (7.5 A, 15 A, 30 A)

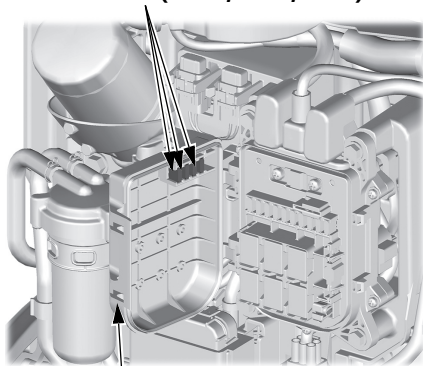

JUNCTION BOX LID

5. Use the fuse puller from the fuse holder to remove the fuses (P.147). If a fuse is blown, install a replacement fuse of the same specified rating. The outboard motor is supplied with spare fuses in the junction box lid.

### MAIN FUSE RATINGS:

7.5 A, 15 A, 30 A

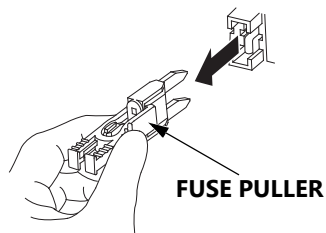

### BLOWN FUSE

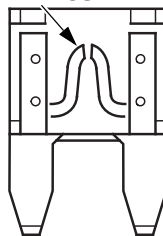

6. Close the junction box lid, and install the front striker guide cover and engine cover.
7. Reconnect the battery.

### NOTICE

- **Never use a fuse with a rating greater than specified. Serious damage to the electrical system could result.**

If a blown fuse is found, try to determine and correct the electrical problem that caused the blown fuse. An uncorrected electrical problem may cause the fuse to blow again.

If fuses continue to blow, take the outboard motor to an authorized marine outboard motor dealer for inspection and service, or refer to the shop manual.

## TAKING CARE OF UNEXPECTED PROBLEMS

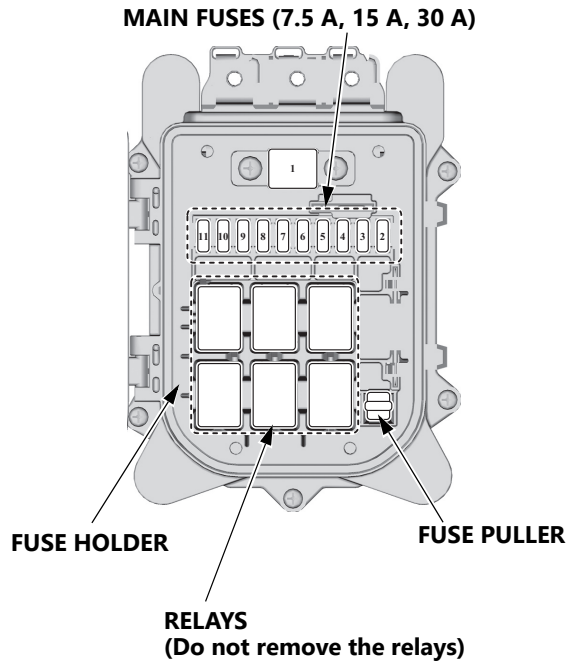

Fuse No.	Rating	Component(s) or Circuit(s) Protected
1	200 A	ACG, Battery
2	15 A	GROUND
3	15 A	Right throttle body
4	30 A	Main relay, Starter relay
5	7.5 A	Remote control box
6	30 A	Shift actuator
7	15 A	Left throttle body
8	15 A	Fuel pump (High pressure side)
9	15 A	Fuel pump (Low pressure side), sensors, ECU
10	15 A	Left side Injectors, Left side Ignition coils
11	15 A	Right side Injectors, Right side Ignition coils
	3 A	Battery switch OFF notification
	7.5 A	Accessory relay

## TAKING CARE OF UNEXPECTED PROBLEMS

### 3 A Fuse, 7.5 A Fuse

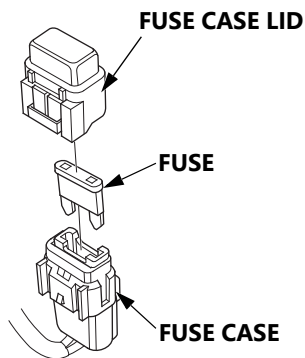
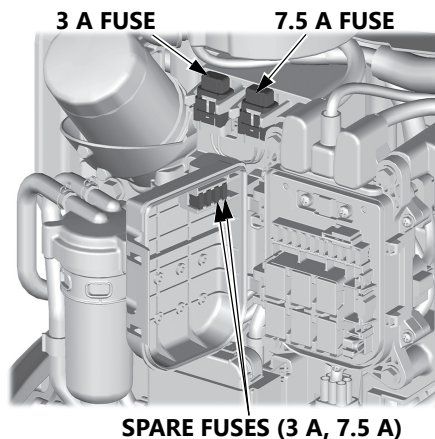

A spare fuse is located on the reverse side of the junction box lid.

1. Stop the engine and disconnect the battery cable.
2. Remove the engine cover. (P.103)
3. Remove the front striker guide cover (P.119).
4. Remove the fuse case lid.
5. Remove the old fuse out of the fuse case with the fuse puller supplied in the fuse holder (P.147).
6. Install a new fuse. The outboard motor is supplied with spare fuse in the junction box lid.  
FUSE RATING:  
3 A, 7.5 A
7. Be sure the fuse case lid is securely locked.

8. Close the junction box lid, and install the front striker guide cover and engine cover.
9. Reconnect the battery.

# TAKING CARE OF UNEXPECTED PROBLEMS

## ACG Fuse

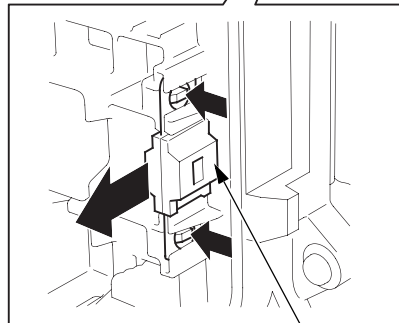
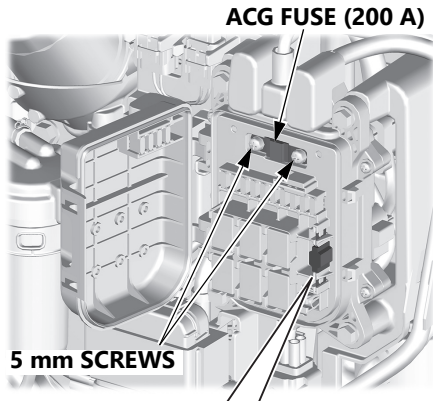

### NOTICE

- **Disconnect the battery cable at the battery terminal before checking or replacing the ACG fuse.**

A spare fuse is located in the fuse holder.

1. Stop the engine and disconnect the battery cable.
2. Remove the engine cover. (P.103)
3. Remove the front striker guide cover (P.119).
4. Open the junction box lid.
5. Remove the old fuse by removing two 5 mm screws.
6. Install a new fuse by tightening two 5 mm screws.  
ACG FUSE: 200 A
7. Close the junction box lid, and install the front striker guide cover and engine cover.
8. Reconnect the battery.

## LOW OIL PRESSURE INDICATOR COMES ON AND ENGINE SPEED IS LIMITED

### Multi-function Display

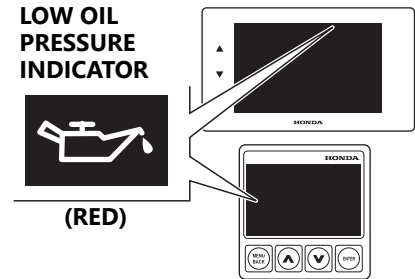

For information about NMEA2000®-compatible device displays, refer to the display device's manual.

## TAKING CARE OF UNEXPECTED PROBLEMS

If oil pressure becomes low, the low oil pressure indicator comes on, and the engine protection system limit engine speed. If you are at cruising speed, engine speed will decrease automatically.

The low oil pressure indicator is also equipped with a buzzer that sounds when the low oil pressure indicator comes on.

Low oil pressure may be the result of a low engine oil level, or there may be a problem with the engine lubrication system.

If the throttle is closed suddenly after full throttle operation, engine speed may drop below the specified idle rpm, and that could activate the engine protection system momentarily.

If low oil pressure activates the engine protection system, stop the engine, check the engine oil level (P.105), and add oil if needed.

With the engine oil at the recommended level, restart the engine. If the lubrication system is OK, the low oil pressure indicator does not come on, and the engine will respond normally to throttle control lever operation.

If the engine protection system remains activated after 30 seconds, return to the nearest boat landing, and have the outboard motor inspected by an authorized marine outboard motor dealer.

## OVERHEAT INDICATOR COMES ON AND ENGINE SPEED IS LIMITED

### *Multi-function Display*

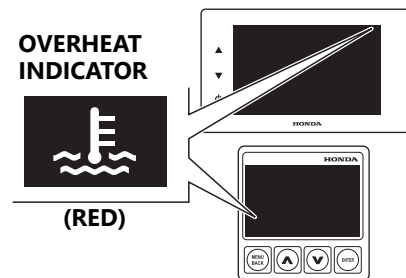

For information about NMEA2000®-compatible device displays, refer to the display device's manual.

## TAKING CARE OF UNEXPECTED PROBLEMS

If the engine overheats, the overheat indicator will come on, and the engine will stop in 20 seconds after the engine protection system limits engine speed. If you are at cruising speed, engine speed will decrease automatically.

All types are equipped with a buzzer that sounds when the overheat indicator comes on.

Engine overheating may be the result of restricted water intake screens, or there may be a problem with the cooling system thermostat or water pump.

If the engine is stopped after running at full throttle, and then restarted soon afterward, that could activate the engine protection system momentarily.

### COOLING SYSTEM INDICATOR

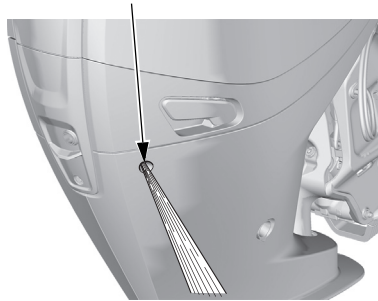

If overheating activates the engine protection system, idle the engine in neutral, and check the cooling system indicator.

If water is flowing from the cooling system indicator, continue idling for 30 seconds. If the cooling system is OK, the overheat indicator should go off within 30 seconds, and the engine will respond normally to throttle control lever operation.

### NOTICE

- **If there is no cooling water flowing from the cooling system indicator or if water vapor is produced, stop the engine, and check whether the cooling water intake port is clogged. If clogged, clean the port. If there is still no cooling water flowing from the cooling system indicator after cleaning, have the outboard motor inspected by an authorized marine outboard motor dealer.**
- **Operating the boat with no cooling water flowing from the cooling system indicator may cause engine damage due to overheating and result in the boat stalling.**

## TAKING CARE OF UNEXPECTED PROBLEMS

---

### WATER SEPARATOR BUZZER SOUNDS

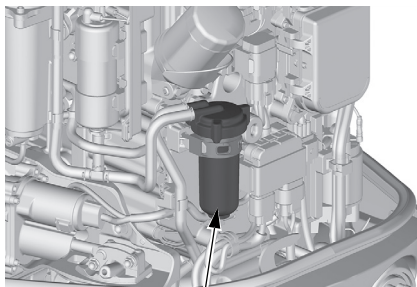

**WATER SEPARATOR**

When the water separator buzzer sounds (a rapid, repeating signal):

Check the water separator for water contamination. If water is present, stop the engine, and clean the water separator following the instructions on P.118, or consult with an authorized Honda Marine outboard motor dealer.

### WHEN COLLIDING WITH AN UNDERWATER OBSTACLE

If you hit an underwater obstacle while underway, stop the engine immediately and inspect the outboard motor for any damage. If there are any abnormalities or if you cannot determine whether there is an abnormality, proceed slowly to the nearest port with extreme caution.

After arriving at the port, have the outboard motor inspected and any necessary repairs carried out by a dealer or service center before restarting the engine.

### SUBMERGED OUTBOARD MOTOR

A submerged outboard motor must be serviced immediately after it is recovered from the water in order to minimize corrosion.

As soon as possible, take the outboard motor to an authorized marine outboard motor dealer for inspection and service.

## TAKING CARE OF UNEXPECTED PROBLEMS

### EMERGENCY GEAR SHIFTING

If shifting cannot be performed with the control lever and the shift actuator is electrically damaged or malfunctioning, manual shifting may be available. Perform the shift operation according to the following procedure, return to port at low speed and consult your servicing dealer.

1. Set the gearshift/throttle control lever (remote control lever) in the NEUTRAL position (P.26-28).
2. Stop the engine (P.68).
3. Remove the engine cover (P.103).
4. Insert the Phillips head screwdriver with the grip from the tool kit (P.99) into the hole of the shift pivot to move the shaft. Shift gear into neutral by aligning the neutral mark and projection of the shift pivot.
5. Grasp the shaft of the inserted Phillips head screwdriver close to the shift pivot.
6. Operate in a stable posture that makes it easy to apply force.
7. Start the engine (P.64).
8. Shift gear into FORWARD or REVERSE by moving the shift pivot with the Phillips head screwdriver with the grip from the tool kit.

After returning to port, stop the engine and anchor the boat.

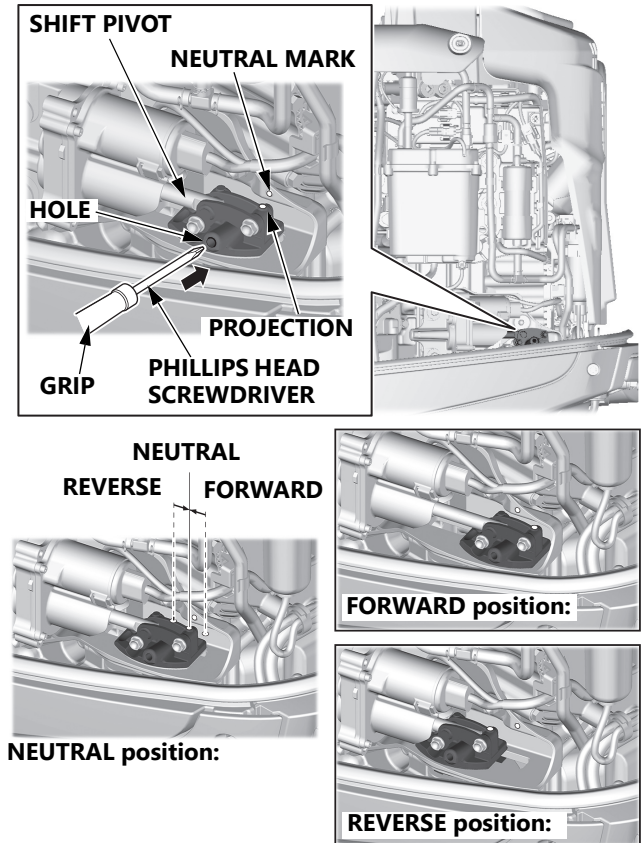

# TECHNICAL INFORMATION

## SERIAL NUMBER LOCATIONS

Record the frame serial number, the engine serial number, and the date of purchase in the space provided on this page. You will need these numbers when ordering parts, and when making technical or warranty inquiries (P.173).

### FRAME SERIAL NUMBER

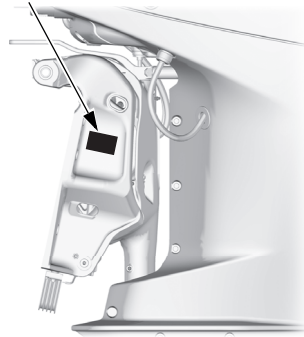

The frame serial number is stamped on a plate attached to the left side of the stern bracket.

Frame Serial Number:

---

Date of purchase:

---

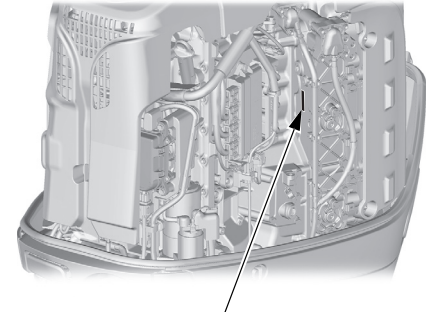

### ENGINE SERIAL NUMBER

The engine serial number is stamped on the upper left side of the engine.

Engine serial number:

---

## BATTERY

### ⚠ WARNING

Batteries produce explosive gases: If ignited, an explosion can cause serious injury or blindness. Provide adequate ventilation when charging.

- **CHEMICAL HAZARD:** Battery electrolyte contains sulfuric acid. Contact with eyes or skin, even through clothing, may cause severe burns. Wear a faceshield and protective clothing.
- Keep flames and sparks away, and do not smoke in the area. **ANTIDOTE:** If electrolyte gets into your eyes, flush thoroughly with warm water for at least 15 minutes and call a physician immediately.

### ⚠ WARNING

- **POISON:** Electrolyte is poison.  
**ANTIDOTE:**
  - External: Flush thoroughly with water.
  - Internal: Drink large quantities of water or milk. Follow with milk of magnesia or vegetable oil, and call a physician immediately.
- **KEEP OUT OF REACH OF CHILDREN.**

Battery posts, terminals, and related accessories contain lead and lead compounds. Wash your hands after handling them.

For complete information, refer to the battery manufacturer's instructions.

## Minimum Requirements

12 V – 92 Ah/5 HR (110 Ah/20 HR)  
(CCA800)

### NOTICE

- **Be careful to avoid connecting the battery in reverse polarity, as this will damage the battery-charging system in the outboard motor.**
- **Do not disconnect the battery cables while the engine is running. Disconnecting the cables while the engine is running will damage the outboard motor's electrical system.**

## TECHNICAL INFORMATION

### NOTICE

- **Battery cable extension:** Extending the original battery cable will cause the battery voltage to drop due to the increased length of the cable and number of connections. This voltage drop may cause the buzzer to sound momentarily when engaging the starter motor and may prevent the engine from starting. If the engine starts and the buzzer sounds momentarily, there may be barely sufficient voltage reaching the engine.

### **▲ WARNING**

Battery posts, terminals, and related accessories contain lead and lead compounds.  
**Wash hands after handling.**

### **EMISSION CONTROL SYSTEM INFORMATION (For US, Puerto Rico, US Virgin Islands and Canada)**

#### ***Source of Emissions***

The combustion process produces carbon monoxide, oxides of nitrogen, and hydrocarbons. Control of hydrocarbons and oxides of nitrogen is very important because, under certain conditions, they react to form photochemical smog when subjected to sunlight. Carbon monoxide does not react in the same way, but it is toxic.

Honda utilizes appropriate air/fuel ratios and other emissions control systems to reduce the emissions of carbon monoxide, oxides of nitrogen, and hydrocarbons.

#### ***PGM-FI System***

The PGM-FI system uses sequential multiport fuel injection. It has three subsystems: Air Intake, Engine Control, and Fuel Control. The Engine Control Module (ECM) uses various sensors to determine how much air is going into the engine. It then controls how much fuel to inject under all operating conditions.

#### ***Ignition Timing Control System***

The system constantly adjusts the ignition timing, reducing the amount of HC, CO, and NOx produced.

### ***The U.S., California Clean Air Acts, and Canadian***

### ***Environmental Protection Act***

EPA, California, and Canadian regulations require all manufacturers to furnish written instructions describing the operation and maintenance of emission control systems.

The following instructions and procedures must be followed in order to keep the emissions from your Honda engine within the emission standards.

### ***Tampering and Altering***

#### **NOTICE**

- **Tampering is a violation of federal and California law.**

Tampering with or altering the emission control system may increase emissions beyond the legal limit. Among those acts that constitute tampering are:

- Alterations that would cause the engine to operate outside its design parameters.
- Removal or alteration of any part of the intake, fuel, or exhaust systems.

### ***Problems That May Affect Emissions***

If you are aware of any of the following symptoms, have your engine inspected and repaired by your servicing dealer.

- Hard starting or stalling after starting
- Rough idle
- Misfiring or backfiring under load
- Afterburning (backfiring)
- Black exhaust smoke or high fuel consumption

## TECHNICAL INFORMATION

---

### **Replacement Parts**

The emission control systems on your Honda engine were designed, built, and certified to conform with EPA, California, and Canadian emission regulations. We recommend the use of Honda Genuine parts whenever you have maintenance done. These original-design replacement parts are manufactured to the same standards as the original parts, so you can be confident of their performance.

Honda cannot deny coverage under the emission warranty solely for the use of non-Honda replacement parts or service performed at a location other than an authorized Honda dealership; you may use comparable EPA certified parts, and have service performed at non-Honda locations. However, the use of replacement parts that are not of the original design and quality

may impair the effectiveness of your emissions control system.

A manufacturer of an aftermarket part assumes the responsibility that the part will not adversely affect emission performance. The manufacturer or rebuilder of the part must certify that use of the part will not result in a failure of the engine to comply with emission regulations.

### **Maintenance**

As the outboard engine owner, you are responsible for completing all required maintenance listed in your owner's manual. Honda recommends that you retain all receipts covering maintenance on your outboard engine, but Honda cannot deny warranty coverage solely for the lack of receipts or for your failure to ensure that all scheduled maintenance has been completed.

Follow the MAINTENANCE SCHEDULE on page 100. Remember that this schedule is based on the assumption that your machine will be used for its designed purpose. Sustained high-load operation, or use in unusual conditions, will require more frequent service.

### STAR LABEL (For US, Puerto Rico, and US Virgin Islands)

A Star label was applied to this outboard motor in accordance with the requirements of the California Air Resources Board.

### *The Star Label means Cleaner Marine Engine*

This engine has been certified as a:



### **The Symbol for Cleaner Marine Engines:**

**Cleaner Air and Water** - for healthier lifestyle and environment.

**Better Fuel Economy** - burns up to 30 - 40 percent less fuel and oil than conventional carbureted two-stroke engines, saving money and resources.

**Longer Emission Warranty** - protects consumer for worry-free operation.

## TECHNICAL INFORMATION

---



**One Star  
Low Emission**

The one-star label identifies engines that meet the Air Resources Board's Personal Watercraft and Outboard marine engine 2001 exhaust emission standards. Engines meeting these standards have 75% lower emissions than conventional carbureted two-stroke engines. These engines are equivalent to the U.S. EPA's 2006 standards for marine engines.



**Two Stars  
Very Low  
Emission**

The two-star label identifies engines that meet the Air Resources Board's Personal Watercraft and Outboard marine engine 2004 exhaust emission standards. Engines meeting these standards have 20% lower emissions than One Star-Low Emission engines.



**Three Stars  
Ultra Low  
Emission**

The three-star label identifies engines that meet the Air Resources Board's Personal Watercraft and Outboard marine engine 2008 exhaust emission standards or the Sterndrive and Inboard marine engine 2003-2008 exhaust emission standards. Engines meeting these standards have 65% lower emissions than One Star-Low Emission engines.



**Four Stars  
Super Ultra  
Low Emission**

The four-star label identifies engines that meet the Air Resources Board's Sterndrive and Inboard marine engine 2009 exhaust emission standards. Personal Watercraft and Outboard marine engines may also comply with these standards. Engines meeting these standards have 90% lower emissions than One Star-Low Emission engines.

Cleaner Watercraft - Get the Facts  
1-800-END-SMOG  
[www.arb.ca.gov](http://www.arb.ca.gov)

## SPECIFICATIONS

MODEL	BF300AK1			
Description Code	BCAJ			
Type	XD	XCD	UD	UCD
Overall length	1,120 mm (44.1 in)			
Overall width	650 mm (25.6 in)			
Overall height	2,145 mm (84.4 in)		2,272 mm (89.4 in)	
Transom height (when transom angle at 12°)	638 mm (25.1 in)		765 mm (30.1 in)	
Dry mass (weight)*	355 kg (783 lbs)		360 kg (794 lbs)	
Rated power	220.7 kW (300 PS) / 223.7 kW (300 HP)**			
Full throttle range	5,000 – 6,000 min <sup>-1</sup> (rpm)			
Engine type	4 stroke OHC VTEC 8-cylinder (V8)			
Displacement	4,952 cm <sup>3</sup> (302.1 cu-in)			
Spark plug gap	1.0 – 1.1 mm (0.039 – 0.043 in)			
Remote control steering system	Motor-mounted			
Starter system	Electric starter			
Ignition system	Fully transistorized, battery ignition			
Lubrication system	Trochoid pump pressure lubrication			
Specified oil	Engine: API standard (SG, SH, SJ, SL) SAE/FC-W 10W-30 Gear case: API standard (GL-4) SAE 90 Hypoid gear oil			

Oil capacity	Engine: Without oil filter change: 10.2 L (10.8 US qt, 9.0 Imp qt) With oil filter change: 10.4 L (11.0 US qt, 9.2 Imp qt) Gear case: 1.72 L (1.82 US qt, 1.51 Imp qt)
CARB star label	ULTRA · LOW EMISSION
D.C. output	12V – 70A
Cooling system	Water cooling with thermostat
Exhaust system	Water exhaust
Spark plugs	ILZKAR7S11E (NGK)
Fuel pump	Electromagnetic type
Fuel	Unleaded gasoline (91 research octane, 86 pump octane, or higher)
Gear change	Forward-Neutral-Reverse (dog type)
Steering angle	30° right and left
Tilt angle (transom angle at 12°)	68° (Stageless)
Trim angle (transom angle at 12°)	– 4° to 15°

\* Without battery cable, with propeller

\*\* US certification value

Honda outboards are power rated in accordance with ISO8665 (propeller shaft output).

Honda outboard motors are power rated in accordance with NMMA procedures and using the ICOMIA standard 28/23.

# TECHNICAL INFORMATION

MODEL	BF350AK1			
Description Code	BBYJ			
Type	XD	XCD	UD	UCD
Overall length	1,120 mm (44.1 in)			
Overall width	650 mm (25.6 in)			
Overall height	2,145 mm (84.4 in)		2,272 mm (89.4 in)	
Transom height (when transom angle at 12°)	638 mm (25.1 in)		765 mm (30.1 in)	
Dry mass (weight)*	355 kg (783 lbs)		360 kg (794 lbs)	
Rated power	257.4 kW (350 PS) / 260.9 kW (350 HP)**			
Full throttle range	5,000 – 6,000 min <sup>-1</sup> (rpm)			
Engine type	4 stroke OHC VTEC 8-cylinder (V8)			
Displacement	4,952 cm <sup>3</sup> (302.1 cu-in)			
Spark plug gap	1.0 – 1.1 mm (0.039 – 0.043 in)			
Remote control steering system	Motor-mounted			
Starter system	Electric starter			
Ignition system	Fully transistorized, battery ignition			
Lubrication system	Trochoid pump pressure lubrication			
Specified oil	Engine: API standard (SG, SH, SJ, SL) SAE/FC-W 10W-30 Gear case: API standard (GL-4) SAE 90 Hypoid gear oil			

Oil capacity	Engine: Without oil filter change: 10.2 L (10.8 US qt, 9.0 Imp qt) With oil filter change: 10.4 L (11.0 US qt, 9.2 Imp qt) Gear case: 1.72 L (1.82 US qt, 1.51 Imp qt)
CARB star label	ULTRA · LOW EMISSION
D.C. output	12V – 70A
Cooling system	Water cooling with thermostat
Exhaust system	Water exhaust
Spark plugs	ILZKAR7S11E (NGK)
Fuel pump	Electromagnetic type
Fuel	Unleaded gasoline (91 research octane, 86 pump octane, or higher)
Gear change	Forward-Neutral-Reverse (dog type)
Steering angle	30° right and left
Tilt angle (transom angle at 12°)	68° (Stageless)
Trim angle (transom angle at 12°)	– 4° to 15°

\* Without battery cable, with propeller

\*\* US certification value

Honda outboards are power rated in accordance with ISO8665 (propeller shaft output).

Honda outboard motors are power rated in accordance with NMMA procedures and using the ICOMIA standard 28/23.

## Noise and Vibration (For Europe)

MODEL	BF300AK1	BF350AK1
CONTROL SYSTEM	R (Remote control)	R (Remote control)
Sound pressure level at operator's ears (2006/42/EC, ICOMIA 39-94)	78 dB (A)	78 dB (A)
----- Uncertainty	2 dB (A)	2 dB (A)
Measured sound power level (Reference to EN ISO3744)	98 dB (A)	99 dB (A)
----- Uncertainty	2 dB (A)	2 dB (A)
Vibration level at hand arm (2006/42/EC, ICOMIA 38-94)	–	–
----- Uncertainty	–	–

Reference to: ICOMIA Standard: as it specifies the engine operating conditions and measurement conditions.

## Compass safe distance (For Europe)

MODEL	BF300AK1	BF350AK1
Compass safe distance (IEC 60945)	450 mm (17.7 in)	

DBW REMOTE CONTROL BOX, KEY SWITCH PANEL, CONTROL UNIT

# MAJOR Honda DISTRIBUTOR ADDRESSES (For Europe)

For further information, please contact Honda Customer Information Centre at the following address or telephone number:

## For European

### AUSTRIA

#### Honda Motor Europe Ltd

Hondastraße 1  
2351 Wiener Neudorf  
Tel.: +43 (0)2236 690 0  
Fax: +43 (0)2236 690 480  
<http://www.honda.at>

✉ [HondaPP@honda.co.at](mailto:HondaPP@honda.co.at)

### BALTIC STATES (Estonia/Latvia/ Lithuania)

#### NCG Import Baltics OU

Meistri 12  
13517 Tallinn  
Harju County Estonia  
Tel.: +372 651 7300  
Fax: +372 651 7301

✉ [info.baltic@ncgimport.com](mailto:info.baltic@ncgimport.com)

### BELARUS

#### JV "Scanlink" Ltd.

Montazhnikov lane 4th, 5-16  
Minsk 220019  
Republic of Belarus  
Tel.: +375172349999  
Fax: +375172380404

✉ [honda@scanlink.by](mailto:honda@scanlink.by)

### BELGIUM

#### Honda Motor Europe Ltd

Wijngaardveld 1  
9300 Aalst  
Tel.: +32 2620 10 00  
Fax: +32 2620 10 01  
<http://www.honda.be>

✉ [cco@honda-eu.com](mailto:cco@honda-eu.com)

### BULGARIA

#### Premium Motor Ltd

Andrey Lyapchev Blvd no 34  
1797 Sofia  
Bulgaria

Tel.: +3592 423 5879  
Fax: +3592 423 5879  
<http://www.hondamotor.bg>  
✉ [office@hondamotor.bg](mailto:office@hondamotor.bg)

### CROATIA

#### Fred Bobek d.o.o.

HONDA MARINE  
Put Gaćezeza 5b  
HR 22211 Vodice  
Tel.: 00385 22 444336  
Fax: 00385 22 440500

✉ [centrala@honda-croatia.com](mailto:centrala@honda-croatia.com)

### CYPRUS

#### Powerline Products Ltd

Cyprus - Nicosia  
Vasilias 18 2232 Latsia  
Tel.: 0035799490421  
✉ [info@powerlinecy.com](mailto:info@powerlinecy.com)  
<http://www.powerlinecy.com>

### CZECH REPUBLIC

#### BG Technik cs, a.s.

U Zavodiste 251/8  
159 00 Praha 5 – Velka Chuchle  
Tel.: +420283870850  
[www.hondamarine.cz](http://www.hondamarine.cz)  
✉ [info@hondamarine.cz](mailto:info@hondamarine.cz)

### DENMARK

#### TIMA A/S

Ryttermarken 10  
DK-3520 Farum  
Tel.: +45 36 34 25 50  
Fax: +45 36 77 16 30  
<http://www.tima.dk>

### FINLAND

#### OY Brandt AB.

Tuupakantie 7B  
01740 Vantaa  
Tel.: +358 207757200  
Fax: +358 9 878 5276  
<http://www.brandt.fi>

### FRANCE

#### Honda Motor Europe Ltd

Division Produit d'Équipement  
Parc d'activités de Pariest,  
Allée du 1er mai  
Croissy Beaubourg BP46, 77312  
Marne La Vallée Cedex 2  
Tel.: 01 60 37 30 00  
Fax: 01 60 37 30 86  
<http://www.honda.fr>

✉ [espace-client@honda-eu.com](mailto:espace-client@honda-eu.com)

### GERMANY

#### Honda Deutschland Niederlassung der Honda Motor Europe Ltd.

Hanauer Landstraße 222-224  
D-60314 Frankfurt  
Tel.: 01805 20 20 90  
Fax: +49 (0)69 83 20 20  
<http://www.honda.de>

✉ [info@post.honda.de](mailto:info@post.honda.de)

# MAJOR Honda DISTRIBUTOR ADDRESSES (For Europe)

For further information, please contact Honda Customer Information Centre at the following address or telephone number:

## For European (continued)

### GREECE

#### Saracakis Brothers S.A.

11 Leoforos Athinon  
104 47 Athens  
Tel.: +30 210 3483300  
Fax: +30 210 3467329  
<http://www.hondamarine.gr/>  
✉ [info@saracakis.gr](mailto:info@saracakis.gr)

### HUNGARY

#### MP Motor Co., Ltd.

Kamaraerdei ut 3.  
2040 Budaors  
Tel.: +36 23 444 971  
Fax: +36 23 444 972  
<http://www.hondakisgepek.hu>  
✉ [info@hondakisgepek.hu](mailto:info@hondakisgepek.hu)

### IRELAND

#### Two Wheels Ltd

M50 Business Park, Ballymount  
Dublin 12  
Tel.: +353 1 4381900  
Fax: +353 1 4607851  
<http://www.hondaireland.ie>  
✉ [sales@hondaireland.ie](mailto:sales@hondaireland.ie)

### ISRAEL

#### Mayer's Cars and Trucks Co.Ltd. - Honda Division

Shevach 5, Tel Aviv, 6777936  
Israel  
+972-3-6953162  
✉ [nirgr@mct.co.il](mailto:nirgr@mct.co.il)  
[www.mct.co.il](http://www.mct.co.il)

### ITALY

#### Honda Motor Europe Ltd

Via della Cecchignola, 13  
00143 Roma  
Tel.: +848 846 632  
Fax: +39 065 4928 400  
<http://www.hondaitalia.com>  
✉ [info.power@honda-eu.com](mailto:info.power@honda-eu.com)

### NORTH MACEDONIA

#### Fred Bobek d.o.o.

HONDA MARINE  
Put Gaćeleza 5b  
HR 22211 Vodice  
Tel.: 00385 22 444336  
Fax: 00385 22 440500  
✉ [centrala@honda-croatia.com](mailto:centrala@honda-croatia.com)

### MALTA

#### Gasanzammit Motors Ltd.

New Street in San Gwakkinn Road  
Mriehel Bypass, Mriehel QRM17  
Tel.: +356 21 498 561  
Fax: +356 21 480 150  
✉ [mgalea@gasanzammit.com](mailto:mgalea@gasanzammit.com)

### NORWAY

#### KELLOX

Box 24, N-141  
Trollåsveien 36, 1414  
Trollåsen, Norway  
Mobile: +47 47 80 90 00  
Phone: +47 64 97 61 00  
<http://kellox.no/>  
✉ [support@kellox.no](mailto:support@kellox.no)

### POLAND

#### Aries Power Equipment

Puławska 467  
02-844 Warszawa  
Tel.: +48 (22) 861 43 01  
Fax: +48 (22) 861 43 02  
<http://www.ariespower.pl>  
<http://www.mojahonda.pl>  
✉ [info@ariespower.pl](mailto:info@ariespower.pl)

### PORTUGAL

#### GROW IBERIA, LDA

Beloura Office Park- Rua do Centro  
Empresarial Edifício 3-Piso1-  
Escritório 8, 2710-693 Sintra- PT  
Tel.: +351 211 303 000  
Fax: +351 211 303 003  
<http://www.grow.com.pt>  
✉ [geral@grow.com.pt](mailto:geral@grow.com.pt)

### ROMANIA

#### Agrisorg SRL

Sacadat Str Principala  
Nr 444/A Jud. Bihor  
Romania  
Tel.: (+4) 0259 458 336  
✉ [info@agrisorg.com](mailto:info@agrisorg.com)

### SERBIA & MONTENEGRO

#### Fred Bobek d.o.o.

HONDA MARINE  
Put Gaćeleza 5b  
HR 22211 Vodice  
Tel.: 00385 22 444336  
Fax.: 00385 22 440500  
✉ [centrala@honda-croatia.com](mailto:centrala@honda-croatia.com)

# MAJOR Honda DISTRIBUTOR ADDRESSES (For Europe)

For further information, please contact Honda Customer Information Centre at the following address or telephone number:

## For European (continued)

### SLOVAK REPUBLIC

**Honda Motor Europe Ltd**  
**Slovensko, organizačná zložka**

Prievozká 6 821 09 Bratislava  
Tel.: +421 2 32131111  
Fax: +421 2 32131112  
<http://www.honda.sk>

### SLOVENIA

**Fred Bobek d.o.o.**

HONDA MARINE  
Put Gačeleza 5b  
HR 22211 Vodice  
Tel.: 00385 22 444336  
Fax.: 00385 22 440500

✉ [centrala@honda-croatia.com](mailto:centrala@honda-croatia.com)

### SPAIN & all Provinces

**Greens Power Products, S.L.**

Poligono Industrial Congost –  
Av Ramon Ciurans n°2  
08530 La Garriga - Barcelona  
Tel.: +34 93 860 50 25  
Fax: +34 93 871 81 80  
<http://www.hondaencasa.com>

### SWEDEN

**Honda Motor Europe Ltd filial**  
**Sverige**

Box 31002 - Långhusgatan 4  
215 86 Malmö  
Tel.: +46 (0)40 600 23 00  
Fax: +46 (0)40 600 23 19  
<http://www.honda.se>  
✉ [hpesinfo@honda-eu.com](mailto:hpesinfo@honda-eu.com)

### SWITZERLAND

**Honda Motor Europe Ltd.**  
**Succursale de Satigny/Genève**

Rue de la Bergère 5  
1242 Satigny  
Tel.: +41 (0)22 989 05 00  
Fax: +41 (0)22 989 06 60  
<http://www.honda.ch>

### TURKEY

**Anadolu Motor Uretim Ve**  
**Pazarlama As Sekerpinar Mah**

Albayrak Sok No 4  
Cayirova 41420  
Kocaeli  
Tel.: +90 262 999 23 00  
Fax: +90 262 658 94 17  
<http://www.anadolumotor.com.tr>  
✉ [antor@antor.com.tr](mailto:antor@antor.com.tr)

### UKRAINE

**Dnipro Motor LLC**

3, Bondarsky Alley,  
Kyiv, 04073, Ukraine  
Tel.: +380 44 537 25 76  
Fax: +380 44 501 54 27  
✉ [oleg.golskiyi@honda.ua](mailto:oleg.golskiyi@honda.ua)

### UNITED KINGDOM

**Honda Motor Europe Ltd**

Cain Road  
Bracknell  
Berkshire  
RG12 1 HL  
Tel.: +44 (0)845 200 8000  
<http://www.honda.co.uk>

# “UK DECLARATION OF CONFORMITY” CONTENT OUTLINE (For Europe)

1) UK-DECLARATION OF CONFORMITY	
2) THE UNDERSIGNED, (13), REPRESENTING THE MANUFACTURER, HEREWITH DECLARES THAT THE PRODUCT IS IN CONFORMITY WITH THE PROVISIONS OF THE FOLLOWING STATUTORY REQUIREMENTS	
The Supply of Machinery (Safety) Regulations 2008	SI 2008 No. 1597
Electromagnetic Compatibility Regulations 2016	SI 2016 No.1091
3) REFERENCE TO DESIGNATED STANDARDS: EN 61000-6-1: 2007, EN 55012:2007+A1:2009	
4) DESCRIPTION OF THE MACHINERY	
5) Generic denomination: Outboard engine    6) Function: Propulsion system    7) MAKE: Honda/Tohatsu	
8) TYPE: <input type="text"/>	9) SERIAL NUMBER: <input type="text"/>
10) Manufacturer: Honda Motor Co., Ltd. 2-1-1 Minamiaoyama Minato-ku Tokyo 107-8556 Japan	
11) Authorized representative and able to compile the technical documentation: Honda Motor Europe Ltd Cain Road, Bracknell, Berkshire, RG12 1HL, United Kingdom	
12) SIGNATURE: <input type="text"/>	
13) NAME: <input type="text"/>	16) DATE: <input type="text"/>
14) TITLE: <input type="text"/>	17) PLACE: <input type="text"/>

# "EC DECLARATION OF CONFORMITY" CONTENT OUTLINE (For Europe)

1) <b>EC-DECLARATION OF CONFORMITY</b>		
2) THE UNDERSIGNED, (13), REPRESENTING THE MANUFACTURER, HEREWITH DECLARES THAT THE PRODUCT IS IN CONFORMITY WITH THE PROVISIONS OF THE FOLLOWING EC-DIRECTIVES  2006/42/EC on machinery, 2014/30/EU on electromagnetic compatibility		
3) REFERENCE TO HARMONIZED STANDARDS: EN 61000-6-1: 2007, EN 55012:2007+A1:2009		
4) <b>DESCRIPTION OF THE MACHINERY</b>		
5) Generic denomination: Outboard engine	6) Function: Propulsion system	7) MAKE: Honda/Tohatsu
8) TYPE: <input type="text"/>	9) SERIAL NUMBER: <input type="text"/>	
10) Manufacturer: Honda Motor Co., Ltd. 2-1-1 Minamiaoyama Minato-ku Tokyo 107-8556 Japan		
11) Authorized representative and able to compile the technical documentation: Honda Motor Europe Ltd – Aalst Office Wijngaardveld 1 (Noord V) 9300 Aalst - Belgium		
12) SIGNATURE: <input type="text"/>		
13) NAME: <input type="text"/>	16) DATE: <input type="text"/>	
14) TITLE: <input type="text"/>	17) PLACE: <input type="text"/>	

# "EC DECLARATION OF CONFORMITY" CONTENT OUTLINE (For Europe)

<p>1) DECLARATION CE DE CONFORMITE 2) LE SOUSSIGNÉ, (13), REPRÉSENTANT DU CONSTRUCTEUR, DÉCLARE PAR LA PRÉSENTE QUE LE PRODUIT EST CONFORME AUX DISPOSITIONS DES DIRECTIVES CE SUIVANTES  3) RÉFÉRENCE AUX NORMES HARMONISÉES 4) DESCRIPTION DE MACHINE  5) Dénomination générique: moteur hors-bord 6) Fonction : Système de propulsion 7) MARQUE  8) TYPE 9) NUMÉRO DI SERIE 10) CONSTRUCTEUR 11) Représentant autorisé et en charge des éditions de documentation techniques  12) SIGNATURE 13) NOM 14) TITRE 15) Directeur Qualité 16) DATE 17) LIEU</p>	<b>français ( FRENCH )</b>
<p>1) DICHIARAZIONE DI CONFORMITA' CE 2) IL SOTTOSCRITTO, (13), RAPPRESENTANTE DEL COSTRUTTORE, DICHIARA QUI DI SEGUITO CHE IL PRODOTTO E' CONFORME A QUANTO PREVISTO DALLE SEGUENTI DIRETTIVE COMUNITARIE  3) RIFERIMENTO ALLE NORME ARMONIZZATE 4) DESCRIZIONE DELLA MACCHINA  5) Denominazione generica: MOTORE FUORIBORDO 6) Funzione : Sistema di propulsione  7) MARCA 8) TIPO 9) NUMERO DI SERIE 10) FABBRICANTE  11) Rappresentante autorizzato e competente per la compilazione della documentazione tecnica  12) FIRMA 13) NOME 14) TITOLO 15) DIRETTORE DELLA QUALITA' 16) ADDI 17) LUOGO</p>	<b>italiano ( ITALIAN )</b>
<p>1) EG-KONFORMITÄTSERKLÄUNG 2) DER UNTERZEICHNER, (13), DER DEN HERSTELLER VERTRITT, ERKLÄRT HIERMIT, DAB DAS PRODUKT IN ÜBEREINSTIMMUNG MIT DEN BESTIMMUNGEN DER NACHSTEHENDEN EG-RICHTLINIEN IST  3) VERWEIS AUF HARMONISIERTE NORMEN 4) BESCHREIBUNG DER MASCHINE  5) Allgemeine Bezeichnung : Außenbordmotor 6) Funktion : Antriebsart  7) FABRIKAT 8) TYP 9) SERIEN NUMMER 10) HERSTELLER  11) Bevollmächtigter und in der Position, die technische Dokumentation zu erstellen  12) UNTERSCHIFT 13) NAME 14) TITEL 15) Qualitätssi Cherung 16) DATUM 17) ORT</p>	<b>deutsch ( GERMAN )</b>
<p>1) EG-VERKLARING VAN OVEREENSTEMMING 2) ONDERGETEKENDE, (13), VERTEGENWOORDIGER VAN DE FABRIKANT, VERKLAART HIERMEE DAT HET PRODUCT VOLDOET AAN DE BEPALINGEN VAN DE VOLGENDE EG-RICHTLIJNEN  3) REFERENTIE NAAR GEHARMONISEERDE NORMEN 4) BESCHRIJVING VAN DE MACHINE  5) Algemene benaming : buitenboordmotor 6) Functie : Aandrijfsysteem  7) FABRIKAT 8) TYPE 9) SERIEN UMMER 10) FABRIKANT  11) Gemachtigde van de fabrikant en in staat om de technische documentatie samen te stellen  12) HANDTEKENING 13) NAAM 14) TITEL 15) Directeur Kwaliteitszorg 16) DATUM 17) PLAATS</p>	<b>nederlands ( DUTCH )</b>
<p>1) ΕΚ-ΔΗΛΩΣΗ ΕΝΑΡΜΟΝΙΣΗΣ 2) Ο ΥΠΟΓΡΑΦΩΝ, (13), ΕΚΠΡΟΣΩΠΟΝΤΑΣ ΤΟΝ ΚΑΤΑΣΚΕΥΑΣΤΗ, ΔΙΑ ΤΟΥ ΠΑΡΟΝΤΟΣ ΔΗΛΩΝΕΙ ΟΤΙ ΤΟ ΠΡΟΪΟΝ ΒΡΙΣΚΕΤΑΙ ΣΕ ΕΝΑΡΜΟΝΙΣΗ ΜΕ ΤΙΣ ΠΡΟΒΛ ΕΦΕΙΣ ΤΩΝ ΚΑΤΩΘΕΙ ΟΔΗΓΙΩΝ ΤΗΣ ΕΕ  3) ΠΑΡΑΠΟΜΠΗ ΣΤΑ ΕΝΑΡΜΟΝΙΣΜΕΝΑ ΠΡΟΤΥΠΑ 4) ΠΕΡΙΓΡΑΦΗ ΜΗΧΑΝΗΜΑΤΟΣ  5) Γενική ονομασία : Εξολέβια μηχανή 6) Λειτουργία : Σύστημα Πρόωσης  7) ΕΡΓΟΣΤΑΣΙΟ ΚΑΤΑΣΚΕΥΗΣ 8) ΤΥΠΟΣ 9) ΑΡΙΘΜΟΣ ΣΕΙΡΑΣ 10) ΚΑΤΑΣΚΕΥΑΣΤΗΣ  11) Εξουσιοδοτημένος αντιπρόσωπος και είναι σε θέση να καταρτίσει τον τεχνικό φάκελο  12) ΥΠΟΓΡΑΦΗ 13) ΟΝΟΜΑ 14) ΤΙΤΛΟΣ 15) Υπεύθυνος Ποιότητας 16) ΗΜΕΡΟΜΗΝΙΑ 17) ΤΟΠΟΣ</p>	<b>Ελληνικά ( GREEK )</b>
<p>1) EF ÖVERENSSTEMMELSESEK LÄRING 2) UNDERTEGNEDE, (13), DER PEPRESENTERER FABRIKANTEN, ERKLÆRER HERMED AT PRODUKTET ER I ÖVERENSSTEMMELSE MED BESTEMMELSERNE I FØLGE EF DIREKTIVERNE  3) REFERENCE TIL HARMONISEREDE STANDARDER 4) BESKRIVELSE AF MASKINEN  5) FÆLLESBETEGNELSE : Utenbordsmotor 6) ANVENDELSE : Fremdrivningssystem 7) FABRIKANT  8) TYPE 9) SERIEN UMMER 10) FABRIKANT  11) AUTORISERET REPRÆSENTANT OG I STAND TIL AT UDARBEJDE DEN TEKNISKE DOKUMENTATION  12) SIGNATURE 13) NAVN 14) TITEL 15) Kvalitets Leder 16) DATO 17) STED</p>	<b>dansk ( DANISH )</b>

# "EC DECLARATION OF CONFORMITY" CONTENT OUTLINE (For Europe)

<p>1) DECLARACIÓN DE CONFORMIDAD 2) EL ABAJO FIRMANTE, (13), EN REPRESENTACIÓN DE FABRICANTE, DECLARA QUE EL PRODUCTO ES CONFORME CON LAS DISPOSICIONES DE LAS SIGUIENTES DIRECTIVAS CE  3) REFERENCIA A ESTÁNDARES ARMONIZADOS 4) DESCRIPCIÓN DE LA MAQUINARIA  5) Denominación genérica : Motor fueraborda 6) Función : Sistema de propulsión 7) MARCA  8) TIPO 9) NUMERO DE SERIE 10) FABRICANTE 11) Representante autorizado que puede compilar el expediente técnico  12) FIRMA 13) NOMBRE 14) CARGO 15) Director de calidad 16) FECHA 17) LUGAR</p>	<b>español ( SPANISH )</b>
<p>1)DECLARAÇÃO CE DE CONFORMIDADE 2) O ABAIXO ASSINADO, (13), EM REPRESENTAÇÃO DO FABRICANTE, PELA PRESENTE DECLARA QUE O PRODUTO ESTÁ EM CONFORMIDADE COM O ESTABELECIDO NAS SEGUINTE DIRETIVAS COMUNITÁRIAS 3) REFERÊNCIA AS NORMAS HARMONIZADAS 4) DESCRIÇÃO DA MÁQUINA  5) Denominação genérica : Motor fora de borda 6) Função : Sistema propulsor  7) MARCA 8) TIPO 9) NÚMERO DE SÉRIE 10) FABRICANTE  11) Mandatário com capacidade para compilar documentação técnica  12) ASSINATURA 13) NOME 14) TÍTULO 15) Director de Qualidade 16) DATA 17) LOCAL</p>	<b>português ( PORTUGUESE )</b>
<p>1) EY-VAATIMUSTENMUKAISUUSVAKUUTUS 2) ALLEKIRJOITANUTAN, (13), JOKA EDUSTAA VALMISTAJAA, VAKUUTTAA TÄTEN, ETTÄ TUOTE ON SEURAAVIEN EU-DIREKTIIVIN VAATIMUSTEN MUKAINEN  3) VITTAUS YHTEISIIN STANDARDEIHIN 4) KUVAUS LAITTEESTA  5) Yleisarvomäärä : Peramoottori 6) Toiminto : Työntöjärjestelmä 7) MERKKI 8) MALLI  9) SARJANUMERO 10) VALMISTAJA 11) Valmistajan edustaja ja teknisten dokumenttien laatija  12) ALLEKIRJOITUS 13) NIMI 14) TITTELI 15) Laatupäällikkö  16) PÄIVÄMÄÄRÄ 17) PAIKKA</p>	<b>suomi / suomen kieli ( FINNISH )</b>
<p>1) ЕО-ДЕКЛАРАЦИЯ ЗА СЪОТВЕТСТВИЕ 2) ДОЛУ ПОДШИСАЛИЯТ СЕ (13), ПРЕДСТАВЛЯВАЩ ДИСТРИБУТОРА, ДЕКЛАРИРА, ЧЕ ПРОДУКТА СЪОТВЕТСТВА НА ИЗСКВАНИЯТА НА СЛЕДНИТЕ ЕВРОПЕЙСКИ ДИРЕКТИВИ  3) СЪОТВЕТСТВИЕ С ХАРМОНИЗИРАНИТЕ СТАНДАРТИ 4) ОПИСАНИЕ НА АРТИКУЛА  5) Общо наименование : ИЗВЪН БОРДОВИ ДВИГАТЕЛ 6) Функция : Задвижваща система  7) МАРКА 8) ТИП 9) СЕРИЕН НОМЕР 10) ПРОИЗВОДИТЕЛ  11) Упълномощен представител и отговорник за съставяне на техническа документация  12) ПОДПИС 13) ИМЕ 14) ТИТЛА 15) МЕНИДЖЪР НА КАЧЕСТВОТО 16) ДАТА 17) МЯСТО</p>	<b>български ( BULGARIAN )</b>
<p>1) EG-FÖRSÄKRAN OM ÖVERENSSTÄMMELSE 2) UNDERTECKNAD, (13), REPRESENTERANDE TILLVERKARE, FÖRSÄKRAR HÄRMEJ ATT PRODUKTEN ÖVERENSSTÄMMER MED BESTÄMMELSERNA I FÖLJANDE EG-DIREKTIVE  3) REFERERANDE TILL HARMONISERADE STANDARDER 4) BESKRIVNING AV UTRUSTNINGEN  5) Allmän benämning : Utomborosmotor 6) Funktion : Framdrivningssystem  7) MERKKI 8) TYPBETECKNING 9) SERIENUMER 10) TILLVERKARE  11) Auktoriserad representant och ska kunna sammanställa teknisk dokumentationen.  12) SIGNATUR 13) NAMN 14) TITEL 15) Kvalitetschef 16) DATUM 17) ORT</p>	<b>svenska ( SWEDISH )</b>
<p>1) DEKLARACJA ZGODNOŚCI WE 2) NIŻEJ PODPISANY (13), REPREZENTUJĄCY PRODUCENTA, DEKLARUJE Z CAŁĄ ODPOWIEDZIALNOŚCIĄ, ŻE PRODUKT SPĘLNI WYMAGANIA ZAWARTE W NASTĘPUJĄCYCH DYREKTYWACH UNIJNYCH  3) ZASTOSOWANE NORMY ZHARMONIZOWANE 4) OPIS URZĄDZENIA  5) Ogólne określenie : Silnik zaburtowy 6) Funkcja : Układ napędowy  7) MАРКА 8) ТYP 9) NUMERY SERYJNE 10) PRODUCENT  11) Upoważniony Przedstawiciel oraz osoba upoważniona do przygotowania dokumentacji technicznej 12) PODPIS  13) NAZWISKO 14) TYTUŁ 15) Menadżer Jakości 16) DATA 17) MIEJSCE</p>	<b>polski ( POLISH )</b>

# "EC DECLARATION OF CONFORMITY" CONTENT OUTLINE (For Europe)

<p>1)MEGFELELŐSEGI NYILATKOZAT 2)ALULÍROTT (13), MINT A GYÁRTÓ KÉPVISELŐJE NYILATKOZIK, HOGY AZ ALABBI TERMÉK MINDENBEN MEGFELEL A KÖVETKEZŐ EC ELŐÍRÁSOK RENDELKEZÉSEINEK: 98/37/EC, 89/336/EEC-93/68/EC:  3)ÖSSZHANGBAN A KÖV. SZABVÁNYOKKAL 4)A GÉP LEÍRÁSA  5) Általános megnevezés : KÜLSŐ CSÓNAKMOTOR 6) Funkció : Hajtás rendszer  7) GYÁRTOTTA 8) TÍPUS 9) SORSZÁM 10) GYÁRTÓ 11) Meghatalmazott képviselője és képes összeállítani a műszaki dokumentációt.  12) ALÁÍRÁS 13) NÉV 14) BEOSZTÁS  15) MINŐSÉGI IGAZGATÓ 16) KELTEZÉS DÁTUMA 17) KELTEZÉS HELYE</p>	<b>magyar ( HUNGARIAN )</b>
<p>1)Prohlášení o shodě 2) ZÁSTUPCE VÝROBCE, (13), SVÝM PODPÍSEM POTVRZUJE, ŽE DANÝ VÝROBEK JE V SOULADU S NÁSLEDUJÍCÍMI SMĚRNICEMI A NORMAMI EVROPSKÉHO SPOLEČENSTVÍ:  3) ODKAZ NA HARMONIZOVANÉ NORMY: 4) POPIS VÝROBKU  5) Všeobecné označení : ZÁVĚSNÝ LODNÍ MOTOR 6) Funkce : Pohonný systém  7) ZNAČKA: 8) TYP: 9) VÝROBNÍ ČÍSLO: 10) VÝROBCE: 11) Zplnomocněný zástupce a osoba pověřená kompletací technické dokumentace  12) PODPIS: 13) JMÉNO: 14) POZICE 15) Manažer kvality 16) DATUM: 17) MÍSTO:</p>	<b>čeština ( CZECH )</b>
<p>1) ES VYHLÁSENIE O ZHODE 2) DOLUPODPÍSANÝ, (13), ZASTUPUJÚCI VÝROBCU, TÝMTO DEKLARUJE, ŽE PRODUKT JE V SÚLADE S USTANOVENIAMÍ NASLEDOVNÝCH SMERNÍC ES  3) REFERENCIA K HARMONIZOVANÝM ŠTANDARDOM 4) IDENTIFIKÁCIA STROJOV  5) Druhové označenie : ZÁVESNÝ LODNÝ MOTOR 6) Funkcia : Systém pohonu  7) VÝROBCA/ZNAČKA 8) TYP 9) SERIOVÉ ČÍSLO  10) VÝROBCA 11) Autorizovaný zástupca schopný zostaviť technickú dokumentáciu 12) PODPIS 13) MENO 14) POZÍCIA  15) MANAŽÉR KVALITY 16) DÁTUM 17) MIESTO</p>	<b>slovenčina ( SLOVAK )</b>
<p>1) EF SAMSVARSÆRKLÆRING 2) UNDERTEGNEDE, (13), SOM REPRESENTERER FABRIKANTEN, ERKLÆRER HERVED AT PRODUKTET ER I OVERENSSTEMMELSE MED BESTEMMELSENE I FØLGENDE EU DIREKTIV  3) REFERANSER TIL HARMONISEREDE STANDARDER 4) BESKRIVELSE AV MASKINEN  5) Felles benevnelse : Utenbordsmotor 6) Funksjon : Fremdrifts system  7) FABRIKANT 8) TYPE 9) SERIE NUMMER 10) FABRIKANT 11) Autorisert representant og i stand til å utarbeide den tekniske dokumentasjonen  12) SIGNATUR 13) NAVN 14) TITTEL 15) Kvalitetssjef 16) DATO 17) STED</p>	<b>norsk ( NORWEGIAN )</b>
<p>1) DECLARATIE DE CONFORMITATE. 2) SUBSEMNATUL, (13), REPREZENTAND PE PRODUCATOR, DECLAR PRIN PREZE NTA CA PRODUSUL ESTE IN CONFORMITATE CU PREVEDERILE URMATOARELOR DIRECTIVE CE  3) REFERIRE LA STANDARDELE ARMONIZATE: 4) DESCRIEREA ECHIPAMENTULUI  5) Denumire generica : MOTOR IN AFARA BORDULUI (EXTERN) 6) Domeniu de utilizare : Sistem de propulsie  7) MARCA 8) TIPUL 9) NUMAR DE SERIE 10) PRODUCATOR 11) Reprezentant autorizat și abilitat să realizeze documentație tehnică  12) SEMNATURA 13) NUME 14) TITLUL 15) DIRECTOR DE CALITATE 16) DATA 17) LOCATIE</p>	<b>română ( ROMANIAN )</b>
<p>1)EÜ VASTAVUSDEKLARATSIOON 2)ALLAKIRJUTANU, (13), ESINDADES TOOTJAT, DEKLAREERIB SIINKOHAL, ET TOODE ON VASTAVUSES JÄRGMISTE EC DIREKTIIVIDE SÄTETEGA  3)VIIDE ÜHTLUSTATUD STANDARDITELE: 4)MEHCHANISMI KIRJELDUS  5)Üldnimetus : Pardaväliline mootor 6) Funktsioon : Tõukurüsteem  7)VALMISTAJA: 8)TÜÜP: 9)SERIANUMBER:  10)TOOTJA: 11) Volitatud esindaja, kes on pädev täitma tehnilist dokumentatsiooni 12)ALLKIRI: 13)NIMI: 14)AMET  15)Kvaliteedijuht 16)KUUPÄEV: 17)KOHT:</p>	<b>eesli ( ESTONIAN )</b>

# “EC DECLARATION OF CONFORMITY” CONTENT OUTLINE (For Europe)

<p>1) EK ATBILSTĪBAS DEKLARĀCIJA 2) ZEMĀK MINĒTAIS, (13), KĀ RAŽOTĀJA PĀRSTĀVIS AR ŠO APSTIPRINA, KA ŠIS PRODUKTS PILNĪBA ATBILST VISIEM STANDARTIEM, KAŠ ATRUNĀTI SEKOJOŠAJĀS EC-DIREKTĪVĀS  3) Atsaucoties uz saskaņotajiem standartiem 4) Iekārtas apraksts  5) Vispārējais nosaukums : Piekarināmais laivas dzinējs 6) Funkcija : Virzošā spēka sistēma  7) Preču zīme 8) Tips 9) Sērijas numurs 10) Izgatavotājs 11) Autorizētais pārstāvis, kas spēj sastādīt tehnisko dokumentāciju 12) Paraksts  13) Vārds, Uzvārds 14) Tituls 15) Kvalitātes vadītājs 16) Datums 17) Vieta</p>	<b>latviešu (LATVIAN)</b>
<p>1) EB ATITIKTĪES DEKLARĀCIJA 2) ŽEMIAUI PASIRAŠES, (13), ATSTOVAUJANTIS GAMINTOJĀ DEKLARUOJA KAD PRODUKTAS ATITINKA REIKALAVĪMUS PAGAL ŠĪS EB DIREKTĪVAS.  3) NUORODA Į HARMONIZUOTUS STANDARTUS. 4) MAŠINOS APRAŠYMAS.  5) Bendras pavadinimas : PAKABINAMAS VARIKLIS 6) Funkcija : Varomasis būdas 7) MARKĖ.  8) TIPAS 9) SERIJINIS NUMERIS. 10) GAMINTOJAS. 11) Įgaliotasis atstovas ir galintis sudaryti techninę dokumentaciją 12) PARAŠAS.  13) V. PAVARDĖ 14) PAREIGOS 15) KOKYBĖS VADYBININKAS. 16) DATA. 17) VIETA</p>	<b>lietuvių kalba (LITHUANIAN)</b>
<p>1) ES-DEKLARACIJA O USTREZNOSTI 2) PODPISANI (13), PREDSTAVNIK PROIZVAJALCA, IZJAVLJAM DA IZDELKI USTREZAJO NASLEDNJIM DEKLARACIJAM  3) SKLADNOST Z NASLEDNJIMI STANDARDI 4) OPIS IZDELKOV  5) Vrsta stroja : Izvenkrmni motorji 6) Funkcija : Pogonski sistem  7) PROIZVAJA 8) TIP 9) SERIJSKA ŠTEVILKA 10) PROIZVAJALEC  11) Pooblaščeni predstavnik ki lahko predloži tehnično dokumentacijo  12) PODPIS 13) IME 14) FUNKCIJA 15) Direktor presoje 16) DATUM 17) KRAJ</p>	<b>slovenščina (SLOVENIAN)</b>
<p>1) EB-YFIRLYSING 2) UNDIRRITADUR HR. (13) LYSI YFIR FYRIR HÖND FRAMLEIÐANDA AÐ VARAN UPPFYLLIR EFTIRFARANDI EC-TILSKIPANIR 3) TILVÍSUN UM HEILDARSTAÐAL 4) LÝSING Á VÉLBÚNAÐI  5) Flokkur : Utanborðsmótorar 6) Virkni : knútingsafl kerfi 7) FRAMLEIÐSLA 8) GERÐ 9) SERIÁL NÚMER 10) FRAMLEIÐANDI  11) Löggildir aðilar og fær um að taka saman tækniskjölin 12) UNDIRSKRIFT 13) NAFN 14) TITILL  15) Skráningarstjóri 16) DAGSETNING 17) STAÐUR</p>	<b>Íslenska (ICELANDIC)</b>
<p>1) AT UYGUNLUK BEYANI 2) AŞAĞIDA İMZASI BULUNAN VE İMALATÇININ YETKİLİ TEMSİLCİSİ OLAN (13) ÜRÜNÜN ŞU AT YÖNETMELİKLERİNİN HÜKÜMLERİNE UYGUN OLDUĞUNU BEYAN EDER.  3) UYUMLAŞTIRILMIŞ STANDARTLARA ATIF 4) MAKİNANIN TARIFI  5) Flokkur : Diştan takma motor 6) Virkni : tahrik sistemi 7) MARKA 8) TİP  9) SERİ NUMARASI 10) İMALATÇI 11) Teknik dosyası hazırlamakla yetkili olan Toplulukta yerleşik yetkili temsilci  12) İMZA 13) ADI 14) ÜNVANI 15) Homologasyon Yöneticisi 16) TARİH 17) YER</p>	<b>Türk (TURKISH)</b>
<p>1) EK-IZJAVA O SUKLADNOSTI 2) POTPIŠANI (13), PREDSTAVNIK PROIZVOĐAČA, IZJAVLJUJE DA JE PROIZVOD U SUKLADNOSTI S ODREDBAMA SLJEDEĆEG EK PROPISA  3) REFERENCA NA USKLAĐENE NORME 4) OPIS STROJA  5) Opća vrijednost : Vanbrodski motor 6) Funkcionalnost : Pogonski sustav  7) IZRADIO 8) TIP  9) SERIJSKI BROJ 10) PROIZVOĐAČ 11) Ovlašteni predstavnik i osoba za sastavljanje tehničke dokumentacije 12) POTPIS 13) IME  14) TITULA 15) Upravitelj homologacije 16) DATUM 17) MJESTO</p>	<b>hrvatski (CROATIAN)</b>

# CONSUMER INFORMATION (For US, Puerto Rico, US Virgin Islands and Canada)

## Dealer Locator Information

To find an authorized Honda Servicing Dealer

For USA:

Visit our website:

<http://marine.honda.com> and click on Find a Dealer

For Canada:

Call 1-888-946-6329 or visit our website:

English

<https://marine.honda.ca/en/dealerlocator>

French

<https://marine.honda.ca/fr/trouver-concessionnaire>

## Honda Publications

These publications will give you additional information for maintaining and repairing your outboard motor.

### ***Shop Manual***

This manual covers complete maintenance and overhaul procedures. It is intended to be used by a skilled technician.

For USA:

Shop manuals are available through your Honda Marine dealer or visit [http://marine.honda.com /Service & Support](http://marine.honda.com/Service&Support) and click on Shop Manuals

For Canada:

Contact your dealer for information on the Shop Manual.

## ***Parts Catalog***

For USA:

This manual provides complete, illustrated parts lists. The catalog is available through your Honda Marine dealer or visit [http://marine.honda.com/Parts & Accessories](http://marine.honda.com/Parts&Accessories) and click on Look Up Parts

For Canada:

Contact your dealer for information on Parts.

Accessory Catalog:

See page 174.

## CONSUMER INFORMATION (For US, Puerto Rico, US Virgin Islands and Canada)

---

### ***Accessory Catalog***

Your authorized Honda Marine dealer offers a wide selection of accessories (optional equipment, oils, and lubricants) to enhance your boating experience.

For USA:

Visit <http://marine.honda.com> and click on PARTS & ACCESSORIES to see the entire catalog of accessories.

For Canada:

Check with your dealer or visit [www.honda.ca](http://www.honda.ca) and select the Parts and Accessories tab under the Honda Marine segment to view the range of accessories available.

### **Customer Service Information**

#### ***Contacting Honda***

Your Owner's Manual was written to cover most of the questions you might ask about your Honda. Any questions not answered in the Owner's Manual can be answered by your Honda dealer. If your dealer doesn't have an immediate answer, they should be able to get it for you.

If you have a difference of opinion with your dealer, please remember that each dealership is independently owned and operated. That's why it's important to work to resolve any differences at the dealership level. If the service personnel are unable to assist you, please discuss your concerns with the dealer management such as the Service Manager or the dealership's owner.

If you need to contact Honda regarding your experiences with your Honda product or with your dealer, please contact the Honda office in your region:

#### **American Honda Motor Co., Inc.**

Marine Division

Customer Relations Office

4900 Marconi Drive Alpharetta,  
GA 30005-8847

Telephone (770) 497 – 6400

M-F 9:00 am-7:30 pm (Eastern  
Time Zone)

## CONSUMER INFORMATION (For US, Puerto Rico, US Virgin Islands and Canada)

In Canada:

### **Honda Canada Inc.**

Customer Relations Department  
180 Honda Boulevard Markham,  
Ontario L6C 0H9

Tel: 1-888-946-6329 (Toll free)

Please include the following information in your communication:

- Your name, address and telephone number (complete with area code)
- Model and complete serial number
- Date of purchase
- Name and location of selling dealer
- Name and location of servicing dealer (if different)
- A detailed description of your concerns

We will likely ask your Honda dealer to respond, or possibly acknowledge your comments directly.

### **Warranty Coverage**

Your new Honda is covered by the following warranties:

- Distributor's Limited Warranty
- Emission Control System Warranty

Please read the warranty information contained in this manual. There are responsibilities, restrictions, and exclusions that apply to these warranties.

To view the complete *Distributor Warranty* statement for USA or Canada, refer to the appropriate URL:  
For USA:  
<https://marine.honda.com> and click on SERVICE & SUPPORT and WARRANTY INFO

For Canada:

English

<https://marine.honda.ca/en/warranty>

French

<https://marine.honda.ca/fr/garantie>

To obtain warranty service you must take your Honda outboard motor, together with proof of original retail purchase date, at your expense, to a Honda engine dealer or distributor authorized to sell that product in the United States, Puerto Rico, the U.S. Virgin Islands or Canada.

It is important to realize that your warranty applies to defects in material or workmanship of your Honda. Your warranty coverage does not apply to normal wear or deterioration associated with using your Honda outboard motor.

## CONSUMER INFORMATION (For US, Puerto Rico, US Virgin Islands and Canada)

---

Your warranty coverage will not be voided if you choose to perform your own maintenance. However, you should have the proper tools and service information and be mechanically qualified. Failures that occur due to modifications, improper maintenance, or service are not covered.

### ***Warranty Service***

Please remember that recommended maintenance interval servicing is not included in your warranty coverage. Additionally, your warranty does not apply to the normal wear of items (such as spark plug(s), water pump, etc.).

As the owner of a Honda product, your servicing dealer may ask you to authorize an inspection. If the problem is covered under warranty, your dealer will perform any warranty repairs for you at no cost. However, you may be responsible for additional non-warranty charges.

If you have questions about warranty coverage or the nature of the repair, it is best to talk to the service manager of your Honda dealer.

Sometimes, in spite of the best intentions of all concerned, a misunderstanding may occur. If you aren't satisfied with your dealer's handling of the situation, we suggest you discuss your problem with the appropriate member of the dealership's management team. If the problem has already been reviewed with the appropriate manager of the Service, Parts, or Sales department, contact the owner of the dealership or their designated representative.

# CONSUMER INFORMATION (For US, Puerto Rico, and US Virgin Islands)

## Emission Control System Warranty

Your new Honda outboard engine complies with both the U.S. EPA and State of California emission regulations.

American Honda provides the same emission warranty coverage for outboard engines sold in all 50 states. In all areas of the United States your outboard engine must be designed, built, and equipped to meet the U.S. EPA and California Air Resources Board emission standard for spark-ignited marine engines.

### **CALIFORNIA EMISSIONS CONTROL SYSTEM WARRANTY STATEMENT YOUR WARRANTY RIGHTS AND OBLIGATIONS**

The California Air Resources Board (CARB) and American Honda Motor Co., Inc. are pleased to explain the emission control system warranty on your 2026 Honda outboard engine. In California, new outboard engines must be designed, built, and equipped to meet the state's stringent anti-smog standards.

American Honda Motor Co., Inc. must warrant the emission control system on your outboard engine for the periods of time listed below provided there has been no abuse, neglect, or improper maintenance of your outboard engine.

Your emission control system may include parts such as the carburetor or fuel injection system, the ignition system, catalytic converter, canisters, clamps, filters, fuel caps, fuel lines, fuel tanks, valves, and vapor hoses. Also included may be hoses, belts, connectors, and other emission-related assemblies.

Where a warrantable condition exists, American Honda Motor Co., Inc. will repair your outboard engine at no cost to you including diagnosis, parts, and labor.

## CONSUMER INFORMATION (For US, Puerto Rico, and US Virgin Islands)

---

### MANUFACTURER'S EMISSION CONTROL SYSTEM WARRANTY COVERAGE:

Select emission control parts are warranted for a minimum of 250 hours of use or the length of the *Honda Marine Distributor's Limited Warranty*.

The evaporative emission control system from model year 2010 and later outboard engines are warranted for two years with no limit on hours of use, or the length of the Honda Marine Distributor's Limited Warranty, whichever is longer, from the date of delivery to the retail purchaser. However, warranty coverage based on the hourly period is only permitted for engines equipped with hour meters as defined in § 2441(a)(13)\* or their equivalent. If any emission-related part on your engine is defective under warranty, the part will be repaired or replaced by American Honda Motor Co., Inc. See the Emission Control System Warranty Parts table on page 182 for parts description.

\* California Code of Regulations

### OWNER'S WARRANTY RESPONSIBILITIES:

As the outboard engine owner, you are responsible for the performance of the required maintenance listed in your owner's manual. American Honda Motor Co., Inc. recommends that you retain all receipts covering maintenance on your outboard engine, but American Honda Motor Co., Inc. cannot deny warranty solely for the lack of receipts or your failure to ensure the performance of all scheduled maintenance.

As the outboard engine owner, you should, however, be aware that American Honda Motor Co., Inc. may deny you warranty coverage if your outboard engine or a part has failed due to abuse, neglect, improper maintenance, or unapproved modifications.

You are responsible for presenting your outboard engine to a Honda Marine dealer as soon as a problem exists. The warranty repairs will be completed in a reasonable amount of time, not to exceed 30 days.

## CONSUMER INFORMATION (For US, Puerto Rico, and US Virgin Islands)

---

If you have any questions regarding your warranty rights and responsibilities, you should contact:

American Honda Motor Co., Inc.  
Marine Division Customer Relations Office  
4900 Marconi Drive  
Alpharetta, Georgia 30005-8847  
Telephone: (770) 497-6400

### **WARRANTY COVERAGE:**

See Manufacturer's Warranty Coverage above for warranty coverage terms. This warranty is transferred to each subsequent purchaser for the duration of the warranty period.

Warranty repairs will be made without charge for diagnosis, parts, and labor. All defective parts replaced under this warranty become the property of American Honda Motor Co., Inc. A list of warranty parts is on the reverse side of this statement. Normal maintenance items, such as spark plugs and filters, that are on the warranted parts list are warranted up to their required replacement interval only. American Honda Motor Co., Inc. is also liable for damages to other engine components caused by a failure of any warranted part during the warranty period.

## CONSUMER INFORMATION (For US, Puerto Rico, and US Virgin Islands)

---

Only Honda approved replacement parts will be used in the performance of any warranty repairs, and they will be provided without charge to the owner. You may use any replacement part as defined in § 1900(b)(20)\* in the performance of any maintenance or repairs. Honda cannot deny coverage under the emission warranty solely for use of non-Honda replacement parts or service performed at a location other than an authorized Honda dealership; however, use of a part that is not functionally identical to the original equipment part in any respect that may in any way affect emissions (including durability) could result in denial of coverage. If a non-Honda replacement part is used in the repair or maintenance of your engine, and an authorized Honda Marine dealer determines it causes the failure of a warranted part, your warranty claim may be denied. If the part in question is not related to the reason that your engine requires repair, your claim will not be denied.

\* California Code of Regulations

### **TO OBTAIN WARRANTY SERVICE:**

You must take your Honda outboard engine, along with your sales registration card or other proof of original purchase date, at your expense, to any Honda Marine dealer that is authorized by American Honda Motor Co., Inc. to sell and service that Honda marine product during its normal business hours. Claims for repair or adjustment found to be caused solely by defects in material or workmanship will not be denied because the engine was not properly maintained and used.

If you are unable to obtain warranty service, or are dissatisfied with the warranty service you received, contact the owner of the dealership involved. Normally this should resolve your problem. However, if you require further assistance, write or call the Honda Marine Customer Relations Office of American Honda Motor Co., Inc.

## CONSUMER INFORMATION (For US, Puerto Rico, and US Virgin Islands)

---

### **EXCLUSIONS:**

Failures other than those resulting from defects in material or workmanship are not covered by this warranty. This warranty does not extend to emission control systems or parts which are affected or damaged by owner abuse, neglect, improper maintenance, misuse, misfueling, improper storage, and/or collision, the incorporation of, or use of, unsuitable attachments, or the unauthorized alteration of any part.

This warranty does not cover replacement of expendable maintenance items made in connection with required maintenance service after the items' first scheduled replacement as listed in the maintenance section of the product owner's manual, such as: spark plugs and filters.

### **DISCLAIMER OF CONSEQUENTIAL DAMAGE AND LIMITATION OF IMPLIED WARRANTIES:**

American Honda Motor Co., Inc. disclaims any responsibility for incidental or consequential damages, such as loss of time or the use of outboard engine, or any commercial loss due to the failure of the equipment; and any implied warranties are limited to the duration of this written warranty. This warranty is applicable only where the California or U.S. EPA emission control system warranty regulation is in effect.

# CONSUMER INFORMATION (For US, Puerto Rico, and US Virgin Islands)

## EMISSION CONTROL SYSTEM WARRANTY PARTS:

SYSTEMS COVERED BY THIS WARRANTY:	PARTS DESCRIPTION:	LENGTH OF WARRANTY:
Evaporative	Portable fuel tank, Outboard internal fuel tank, Fuel cap, Fuel hoses, Primer bulb, Fuel hose joint, Vapor separator, and Carbon canister, All other parts not listed that may affect the evaporative emissions control system	Two years, no limit on hours of use; or the length of the Honda Distributor's Limited Warranty, whichever is longer.
Fuel Metering	Carburetor assembly, Throttle body, Fuel injector, Fuel pump, Fuel pressure regulator, Throttle position sensor, Intake air temperature sensor, Engine temperature sensor, Manifold absolute pressure sensor, Idle air control valve, Barometric pressure sensor, Fuel line solenoid valve, Intake manifold, Intake valves, and Oxygen sensor or Air/fuel ratio sensor	Minimum of 250 hours of use or the length of the <i>Honda Distributor's Limited Warranty</i> .
Air Induction	Air intake duct, Intake manifold tuning valve (Intake air bypass control valve)	
Ignition	Flywheel magneto, Ignition pulse generator, Ignition coil assembly, Ignition control module, Engine control module, Crankshaft position sensor, Spark plug cap, Spark plug*, Knock sensor, and Camshaft position sensor	
Lubrication System	Oil pump and internal parts	
Crankcase Emission Control	Crankcase breather tube, Positive crankcase ventilation valve, Oil filler cap	
Exhaust	Exhaust manifold and Exhaust valves	
Valve Control System	Rocker arm oil control valve	
Miscellaneous Parts	Tubing, fittings, seals, gaskets, wires, and clamps associated with these listed systems.	

\* Covered up to the first required replacement only. See the Maintenance Schedule on page 100.

# INDEX

<b>1</b>	
1 LEVER Switch .....	34, 81
<b>3</b>	
3 A Fuse.....	148
<b>7</b>	
7.5 A Fuse .....	148
<b>A</b>	
ACG Fuse.....	149
ACG INDICATOR/BUZZER	
Operation.....	93
Active Mode.....	31, 67
ACTIVE Switch.....	31, 67
ACTIVE/FAST IDLE Switch.....	31, 67
Alternator (ACG) Indicator .....	45
ANODE .....	49
INSPECTION.....	122
Automatic Tilt Mode .....	87
<b>B</b>	
BATTERY.....	155
Battery Will Not Charge .....	145
Cleaning.....	126
Connections .....	54
Inspection .....	125
Storage.....	133
Battery Switch OFF Notification .....	50
BEFORE OPERATION.....	59
BREAK-IN PROCEDURE .....	62
<b>C</b>	
CLEANING AND FLUSHING.....	127
COMMON CONTROLS.....	37
COMPONENT AND CONTROL LOCATIONS.....	14
CONSUMER INFORMATION	
For US, Puerto Rico, and US Virgin Islands.....	177
For US, Puerto Rico, US Virgin Islands and Canada.....	173
CONTROL AND FEATURE IDENTIFICATION CODES .....	12
CONTROLS.....	22
CONTROLS AND FEATURES.....	12
Cooling System Indicator .....	47
COOLING WATER INTAKE PORT .....	48
Cruise Control Mode .....	81
CRUISE/UP Switch .....	35, 80
CRUISING .....	75
Customer Service Information.....	174
<b>D</b>	
Dealer Locator Information.....	173
DISPOSAL.....	138



**H**  
HARD STARTING OR STALLS AFTER STARTING ..... 141  
HOISTING THE OUTBOARD MOTOR ..... 135  
Honda Publications ..... 173  
Honda Smart Key ..... 23  
HOW TO DETERMINE WHICH DIRECTION THE  
PROPELLER SHAFT ROTATES ..... 13

**I**  
Ignition Switch ..... 22  
IMPORTANT SAFETY INFORMATION ..... 7  
INDICATOR ..... 94  
INDICATORS ..... 45  
INFREQUENT OR OCCASIONAL USE ..... 64  
INSTALLATION ..... 51  
    Height ..... 52  
    Location ..... 52  
    Outboard Motor ..... 52  
IS YOUR OUTBOARD MOTOR READY TO GO? ..... 59

**L**  
Low Oil Pressure Indicator ..... 46  
LOW OIL PRESSURE INDICATOR COMES ON AND  
ENGINE SPEED IS LIMITED ..... 149  
LOW OIL PRESSURE INDICATOR/OIL PRESSURE  
INDICATOR/BUZZER  
    Operation ..... 93

LUBRICATION POINTS ..... 109

**M**  
Main Fuse ..... 146  
MAINTENANCE SAFETY ..... 98  
MAINTENANCE SCHEDULE ..... 100  
MAJOR Honda DISTRIBUTOR ADDRESSES ..... 164  
Malfunction (PGM-FI) Indicator ..... 45  
Manual Relief Valve ..... 39, 89  
MOORING, BEACHING, LAUNCHING ..... 83  
MULTIPLE OUTBOARD MOTORS ..... 89

**N**  
NMEA 2000® Interface Coupler ..... 42  
Normal Engine Stopping ..... 69

**O**  
One-lever Mode ..... 81  
Operating Hour Notification System ..... 42  
OPERATION ..... 62  
OTHER FEATURES ..... 48  
OUTBOARD MOTOR  
    Angle Inspection ..... 53  
    Installation ..... 52  
OUTBOARD MOTOR SAFETY ..... 7  
Overheat Indicator ..... 47

# INDEX

OVERHEAT INDICATOR COMES ON AND ENGINE SPEED IS LIMITED .....	150	Select Switch.....	29
OVERHEAT INDICATOR/BUZZER		SERIAL NUMBER LOCATIONS.....	154
Operation.....	93	SERVICING YOUR OUTBOARD MOTOR .....	97
OWNER'S MANUAL.....	99	SHALLOW WATER OPERATION.....	83
<b>P</b>		SPARE EMERGENCY STOP SWITCH CLIP.....	100
PGM-FI INDICATOR/BUZZER		SPARK PLUG SERVICE.....	112
Operation.....	93	SPECIFICATIONS.....	161
Power Harness Fuse .....	145	STAR LABEL.....	159
Power Reduction.....	50	START/STOP Switch .....	24
Power Switch.....	22	STARTING THE ENGINE.....	64
Power Tilt Switch.....	39, 88	STEERING .....	74
Power Trim/Tilt Switch.....	37, 75	STOPPING THE ENGINE .....	68
PROPELLER		Emergency Engine Stopping.....	68
Replacement.....	123	Normal Engine Stopping.....	69
Selection .....	58	STORAGE.....	130
<b>R</b>		ENGINE OIL.....	133
REFUELING .....	116	FUEL .....	130
REMOTE CONTROL INSTALLATION.....	56	STORAGE PRECAUTIONS .....	135
REMOVAL FROM STORAGE.....	135	SUBMERGED OUTBOARD MOTOR.....	152
Rev Limiter.....	49	<b>T</b>	
<b>S</b>		TAKING CARE OF UNEXPECTED PROBLEMS .....	139
SAFE OPERATING PRECAUTIONS.....	62	TECHNICAL INFORMATION .....	154
SAFETY LABEL LOCATION .....	10	THE IMPORTANCE OF MAINTENANCE .....	97
		Tilt Lock Lever .....	40, 85
		TOOL KIT .....	99
		TRANSOM HEIGHT.....	51

---

TRANSPORTING .....	136
Trim .....	75
TRIM SPT. Switch.....	37
Trim Support Mode.....	37, 78
TROLL/DN Switch.....	33
Trolling Control Mode .....	33, 80
TURNING WHEN MULTIPLE ENGINES ARE MOUNTED .....	90
 <b>U</b>	
UK DECLARATION OF CONFORMITY CONTENT OUTLINE .....	167
 <b>W</b>	
Water Separator Buzzer.....	48
WATER SEPARATOR BUZZER SOUNDS.....	152
WHEN COLLIDING WITH AN UNDERWATER OBSTACLE .....	152

# MEMO



# HONDA

31ZVP620  
00X31-ZVP-6200



英 AB 0000.00AA.AA  
Printed in Japan