

HONDA

GENERATOR EX2400/EX2400S

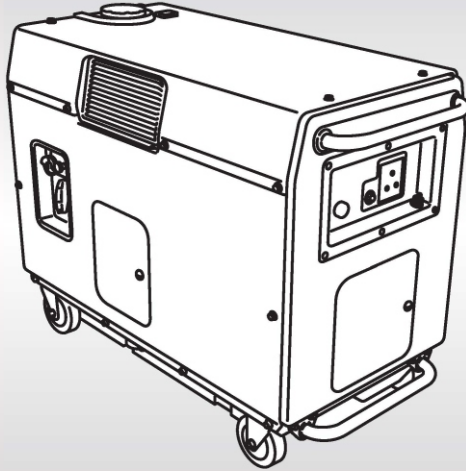

OWNER'S MANUAL

ग्राहक पुस्तिका

Honda India Power Products Limited

होण्डा इंडिया पॉवर प्रोडक्ट्स लिमिटेड



Honda EX2400/EX2400S

OWNER'S MANUAL

ग्राहक पुस्तिका

Keep this owner's manual handy so that you can refer to it at any time. This owner's manual is considered a permanent part of the generator and should remain with the generator if resold.

The information and specifications included in this publication were in effect at the time of approval for printing. Honda India Power Products Ltd. reserves the right, however, to discontinue or change specifications or design at any time without notice and without incurring any obligation whatsoever.

Honda Selling Dealer

Name : _____

Address : _____

Tel. No. : _____

P. I. C. Date : _____

Warranty valid upto : _____

Usage Type : Commercial Non-commercial Rental

INTRODUCTION

Congratulations on your selection of a Honda generator. We are certain you will be pleased with your purchase of one of the finest generators in the market.

We want to help you get the best results from your new generator and to operate it safely. This manual contains all the information on how to do that; please read it carefully.

As you read this manual, you will find information preceded by a **NOTICE** symbol. That information is intended to help you avoid damage to your generator, other property, or the environment.

We suggest you read the warranty policy to fully understand its coverage and your responsibilities of ownership.

When your generator needs scheduled maintenance, keep in mind that your Honda servicing dealer is specially trained in servicing Honda generators. Your authorized Honda servicing dealer is dedicated to your satisfaction and will be pleased to answer your questions and concerns.

We welcome your valuable suggestions & feedback.

Kindly send your feedback
to Marketing Manager:

or else

contact our Customer Care
Centre for Support :

Best Wishes,
Honda India Power Products Ltd.

Honda India Power Products Limited
Phone No.: 0120-2590100
e-mail : ho.mktg@hipp.co.in
Working Hours : 08:15 A.M. to 05:15 P.M. (Mon to Fri)

Toll Free No. : **1800 11 2323**
Working Hours : 09:00 A.M. to 07:00 P.M.
(Available Monday to Sunday except on Public Holidays)

To access information about Operations,
Maintenance & Troubleshooting, please visit:
www.hppsv.com/IND/ or scan



INTRODUCTION

A FEW WORDS ABOUT SAFETY

Your safety and the safety of others are very important. And using this generator safely is an important responsibility.

To help you make informed decisions about safety, we have provided operating procedures and other information on labels and in this manual. This information alerts you to potential hazards that could hurt you or others.

Of course, it is not practical or possible to warn you about all the hazards associated with operating or maintaining a generator. You must use your own good judgement.

You will find important safety information in a variety of forms, including:

- **Safety Labels**— on the generator.
- **Safety Messages**— preceded by a safety alert symbol  and one of three signal words, DANGER, WARNING, or CAUTION.

These signal words mean:

 **DANGER**

You **WILL** be **KILLED** or **SERIOUSLY HURT** if you don't follow instructions.

 **WARNING**

You **CAN** be **KILLED** or **SERIOUSLY HURT** if you don't follow instructions.

 **CAUTION**

You **CAN** be **HURT** if you don't follow instructions.

- **Safety Headings**— such as *IMPORTANT SAFETY INFORMATION* .
- **Safety Section**— such as *GENERATOR SAFETY*.
- **Instructions**— how to use this generator correctly and safely.

This entire book is filled with important safety information – please read it carefully.

The illustrations herein are mainly based on: EX2400S

- The illustration may vary according to the model.

CONTENTS

GENERATOR SAFETY	5
IMPORTANT SAFETY INFORMATION	5
Operator Responsibility.....	5
Carbon Monoxide Hazards	5
Electric Shock Hazards.....	6
Fire and Burn Hazards	6
Refuel With Care	6
SAFETY LABEL LOCATIONS	7
CONTROLS & FEATURES	10
COMPONENT & CONTROL LOCATIONS	10
CONTROLS	13
Fuel Valve Knob	13
Choke Knob	13
Engine Switch	14
Starter Grip	14
AC Circuit Protector	15
Maintenance Covers.....	16
Fuel Gauge	17
Wheel Stopper	17
FEATURES	18
Oil Alert System	18
Ground Terminal	18
BEFORE OPERATION	19
ARE YOU READY TO GET STARTED?	19
Knowledge	19
IS YOUR GENERATOR READY TO GO?	19
Check the Engine	20
OPERATION	21
SAFE OPERATING PRECAUTIONS	21
STARTING THE ENGINE	22
STOPPING THE ENGINE	25
AC OPERATION	26
AC Applications	27
STANDBY POWER	28
Connections to a Building's Electrical System	28
System Ground	29
Special Requirements	29

CONTENTS

SERVICING YOUR GENERATOR	30
THE IMPORTANCE OF MAINTENANCE	30
MAINTENANCE SAFETY	31
Safety Precautions	31
MAINTENANCE SCHEDULE	32
REFUELING	33
FUEL RECOMMENDATIONS	34
ENGINE OIL LEVEL CHECK	35
ENGINE OIL CHANGE	36
ENGINE OIL RECOMMENDATIONS	38
AIR CLEANER SERVICE	39
FOAM AIR FILTER CLEANING	41
SPARK PLUG SERVICE	42
BATTERY SERVICE (EX2400S only).....	44
Emergency Procedures	44
Battery Removal	45
Battery Charging	46
Battery Installation	46
FUSE (EX2400S only)	47
STORAGE	48
STORAGE PREPARATION	48
Cleaning	48
Fuel	48
STORAGE PROCEDURE	49
STORAGE PRECAUTIONS	51
REMOVAL FROM STORAGE	51
TRANSPORTING	52
BEFORE TRANSPORTING	52
WHEN TRANSPORTING THE GENERATOR	52
Transporting the Generator by Truck	53
TAKING CARE OF UNEXPECTED PROBLEMS	54
ENGINE PROBLEMS	54
Engine Will Not Start	54
Engine Lacks Power	54
GENERATOR PROBLEMS	55
No Power at the AC Receptacle	55
TECHNICAL INFORMATION	56
SERIAL NUMBER LOCATIONS	56
CARBURETOR MODIFICATION FOR HIGH ALTITUDE OPERATION	57
SPECIFICATIONS	58
WARRANTY POLICY	59
INSTALLATION AND FREE SERVICES	60
LIST OF AREA OFFICES	61
DISPOSAL	62

GENERATOR SAFETY

IMPORTANT SAFETY INFORMATION

Honda generators are designed for use with electrical equipment that has suitable power requirements. Other use can result in injury to the operator or damage to the generator and other property.

Most injuries or property damage can be prevented if you follow all instructions in this manual and on the generator. The most common hazards are discussed below, along with the best way to protect yourself and others.

Operator Responsibility

- Know how to stop the generator quickly in case of emergency.
- Understand the use of all generator controls, output receptacles, and connections.
- Be sure that anyone who operates the generator receives proper instruction. Do not let children operate the generator without parental supervision.

Carbon Monoxide Hazards

A generator's exhaust contains toxic carbon monoxide, which you cannot see or smell. Breathing carbon monoxide can KILL YOU IN MINUTES. To avoid carbon monoxide poisoning, follow these instructions when operating a generator:

- Only run a generator OUTSIDE, far away from windows, doors, and vents.
- Never operate a generator inside a house, garage, basement, crawl space, or any enclosed or partially enclosed space.
- Never operate a generator near open doors or windows.
- Get fresh air and seek medical attention immediately if you suspect you have inhaled carbon monoxide.

Early symptoms of carbon monoxide exposure include headache, fatigue, shortness of breath, nausea, and dizziness. Continued exposure to carbon monoxide can cause loss of muscular coordination, loss of consciousness, and then death.

GENERATOR SAFETY

Electric Shock Hazards

- The generator produces enough electric power to cause a serious shock or electrocution if misused.
- Do not use in wet conditions. Keep the generator dry.
 - Do not use in the rain or snow.
 - Do not use near a pool or sprinkler system.
 - Do not use when your hands are wet.
- If the generator is stored outdoors, unprotected from the weather, check all of the electrical components on the control panel before each use. Moisture or ice can cause a malfunction or short circuit in electrical components that could result in electrocution.
- Do not connect to a building's electrical system unless an isolation switch has been installed by a qualified electrician.

Fire and Burn Hazards

- The exhaust system gets hot enough to ignite some materials.
 - Keep the generator at least 1 meter away from buildings and other equipment during operation.
 - Do not enclose the generator in any structure.
 - Keep flammable materials away from the generator.
- The muffler becomes very hot during operation and remains hot for a while after stopping the engine. Be careful not to touch the muffler while it is hot. Let the engine cool before storing the generator indoors.

Refuel With Care

Petrol is extremely flammable, and petrol vapor can explode.

Allow the engine to cool if the generator has been in operation.

Refuel only outdoors in a well-ventilated area with the engine off.

Do not refuel during operation.

Do not overfill the fuel tank.

Never smoke near petrol, and keep other flames and sparks away.

Always store petrol in an approved container.

Make sure that any spilled fuel has been wiped up before starting the engine.

GENERATOR SAFETY

SAFETY LABEL LOCATIONS

These labels warn you of potential hazards that can cause serious injury. Read them carefully. If a label comes off or becomes hard to read, contact your authorized Honda servicing dealer for a replacement.

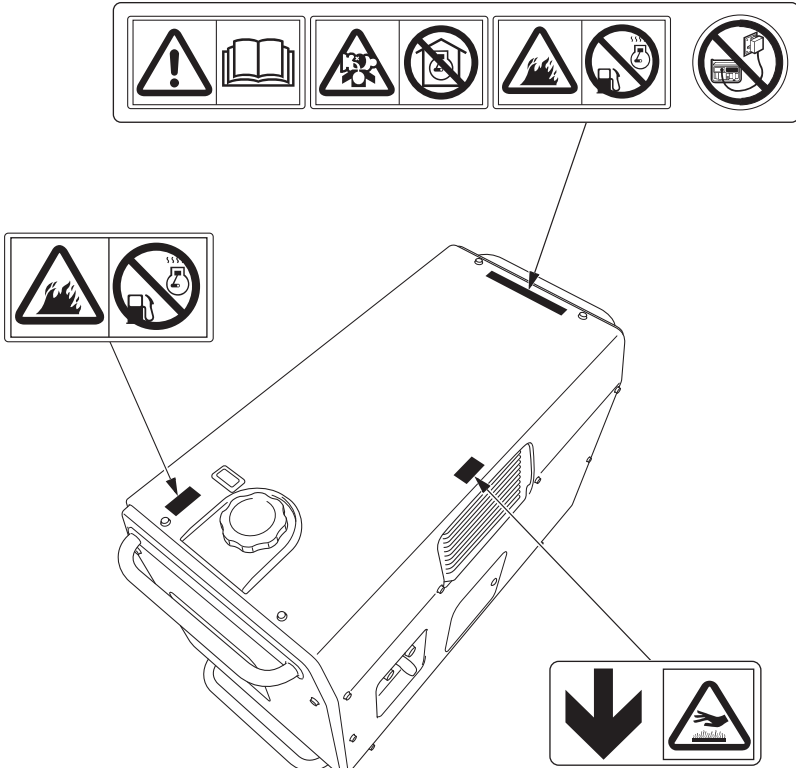

GENERATOR SAFETY



- Honda generator is designed to give safe and dependable service if operated according to instructions. Read and understand the Owner's Manual before operating the generator. Failure to do so could result in personal injury or equipment damage.



- Exhaust contains poisonous carbon monoxide, a colorless, odorless gas. Breathing carbon monoxide can cause loss of consciousness and may lead to death.
- If you run the generator in an area that is confined, or even partially enclosed area, the air you breathe could contain a dangerous amount of exhaust gas.
- Never run your generator inside a garage, house or near open windows or doors.



- Petrol is highly flammable and explosive. Turn the engine off and let it cool before refueling.

GENERATOR SAFETY



- Do not connect to a building's electrical system unless an isolation switch has been installed by a qualified electrician.
- Connections for standby power to a building's electrical system must be made by a qualified electrician and must comply with all applicable laws and electrical codes. Improper connections can allow electrical current from the generator to backfeed into the utility lines. Such backfeed may electrocute utility company workers or others who contact the lines during a power outage, and when utility power is restored, the generator may explode, burn, or cause fires in the building's electrical system.



- A hot exhaust system can cause serious burns. Avoid contact if the engine has been running.

CONTROLS & FEATURES

COMPONENT & CONTROL LOCATIONS

Use the illustrations on these pages to locate and identify the most frequently used controls.

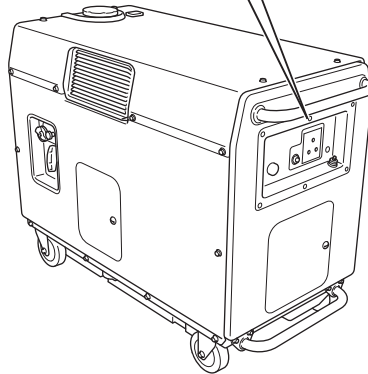
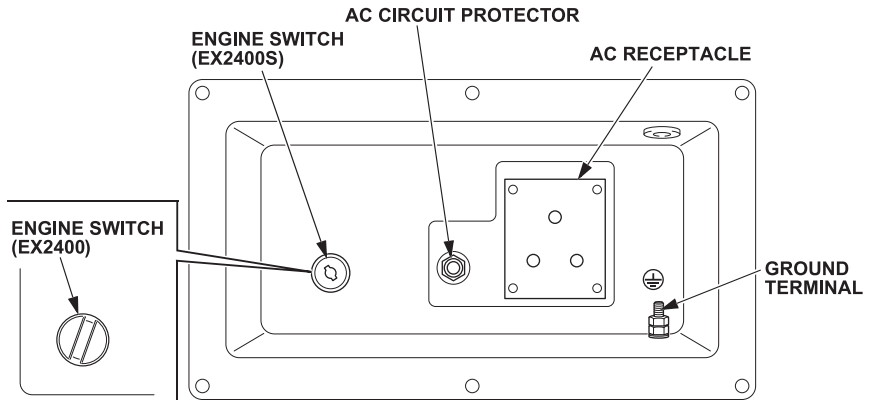

CONTROLS & FEATURES

LEFT MAINTENANCE COVER
AIR CLEANER

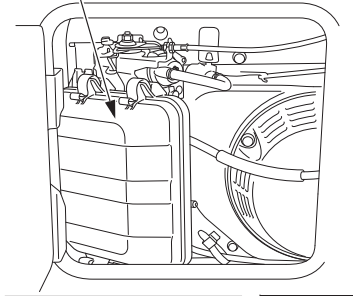

FUEL GAUGE

FUEL TANK CAP

MUFFLER

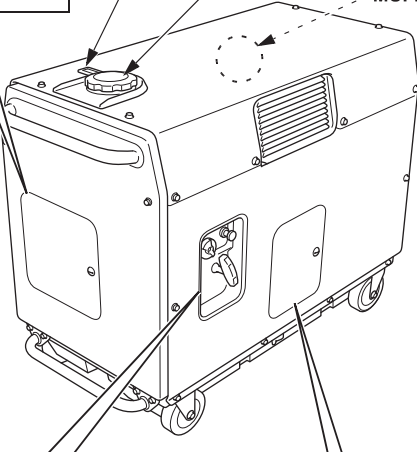

FUEL VALVE KNOB
CHOKE KNOB

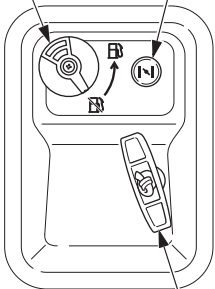

STARTER GRIP

FRONT MAINTENANCE COVER
OIL FILLER CAP

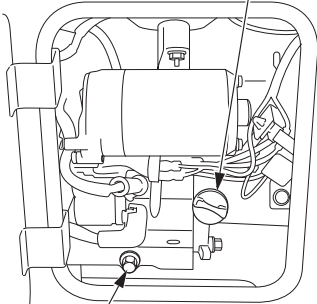

OIL DRAIN PLUG

CONTROLS & FEATURES

EX2400S only
RIGHT MAINTENANCE COVER
BATTERY FUSE

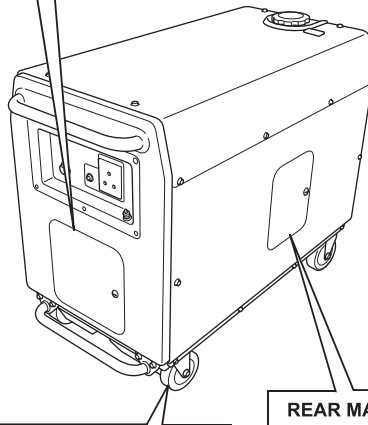
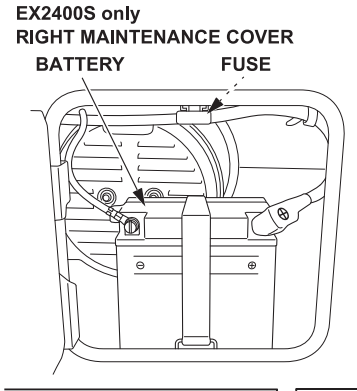

WHEEL STOPPER

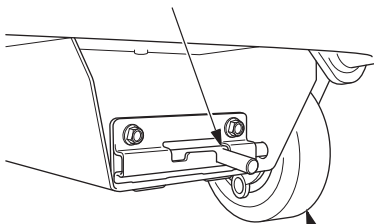

WHEEL (4)

REAR MAINTENANCE COVER

SPARK PLUG SPARK PLUG CAP

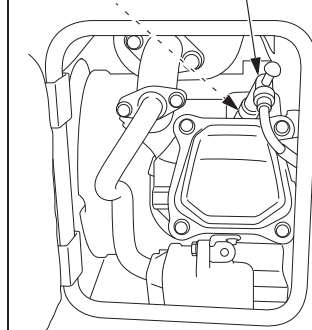

CONTROLS & FEATURES

CONTROLS

Fuel Valve Knob

The fuel valve knob must be in the ON position for the engine to run.

After stopping the engine, turn the fuel valve knob to the OFF position.

Choke Knob

The choke knob opens and closes the choke valve in the carburetor.

The CLOSED position enriches the fuel mixture for starting a cold engine.

The OPEN position provides the correct fuel mixture for operation after starting, and for restarting a warm engine.

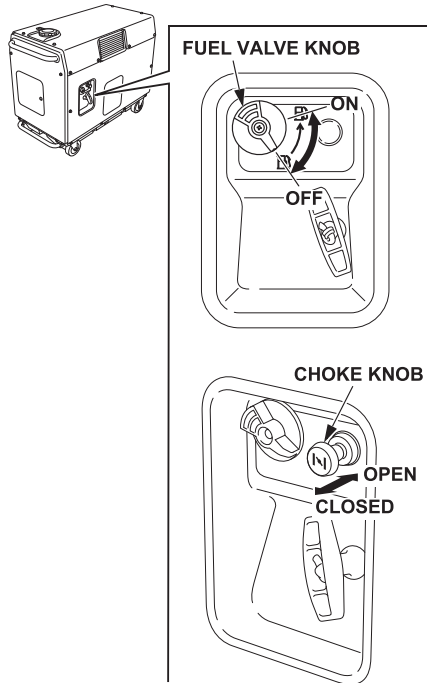

CONTROLS & FEATURES

Engine Switch

The engine switch controls the ignition system.

EX2400:

OFF – Stops the engine.

ON – Running position.

EX2400S:

OFF – Stops the engine.

The engine switch key can be removed/inserted.

ON – Running position.

START – Operates the electric starter.

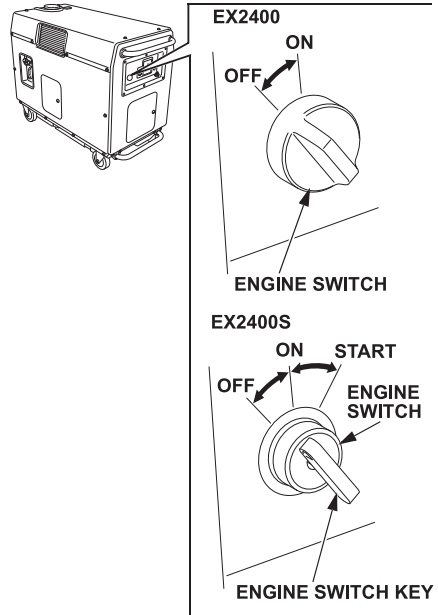

Starter Grip

Pulling the starter grip operates the recoil starter to crank the engine for starting.

NOTICE

- Do not allow the starter grip to snap back against the generator. Return it gently to prevent damage to the starter.
- Do not let the starter rope rub against the generator body, or the rope will wear out prematurely.

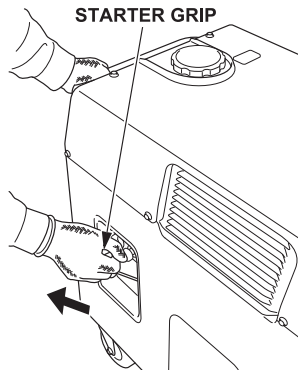

CONTROLS & FEATURES

AC Circuit Protector

The AC circuit protector will automatically switch OFF (push button comes out) if there is a short circuit or a significant overload of the generator at the receptacle.

If an AC circuit protector switch OFF automatically, check that the appliance is working properly and does not exceed the rated load capacity of the circuit before resetting the AC circuit protector ON (pushing the push button in).

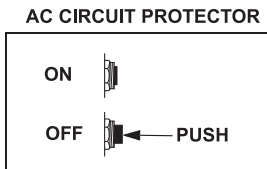
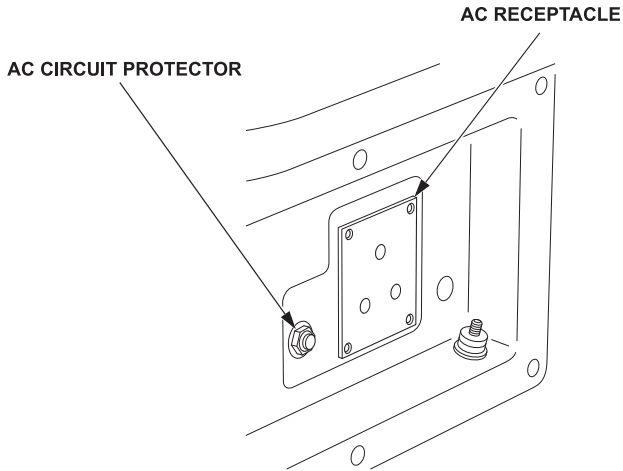

CONTROLS & FEATURES

Maintenance Covers

Maintenance cover location.

FRONT MAINTENANCE COVER

- Engine oil level check
- Engine oil change

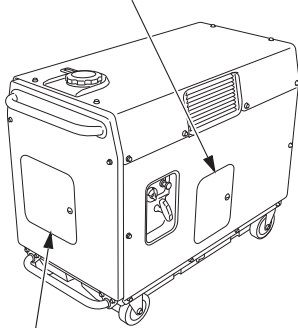

LEFT MAINTENANCE COVER

- Air cleaner inspection/cleaning

REAR MAINTENANCE COVER

- Spark plug inspection/replacement
- Carburetor drain

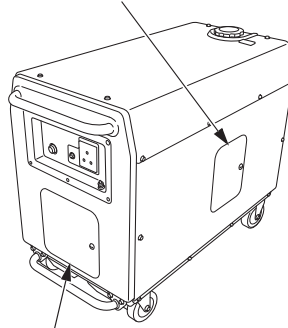

EX2400S only: RIGHT MAINTENANCE COVER

- Battery installation/removal
- Fuse replacement

Be sure the maintenance covers are closed while the generator is running.

To open:

Turn the latch 90° clockwise.

To close:

Turn the latch 90° counterclockwise to lock while pushing the cover.

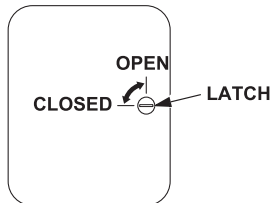

CONTROLS & FEATURES

Fuel Gauge

The fuel gauge is a mechanical device that measures the fuel level in the tank. The red indicator in the window will reference the fuel level. To provide increased operating time, start with a full tank before operation. Check the fuel level with the generator on a level surface. Always refuel with the engine OFF and cool.

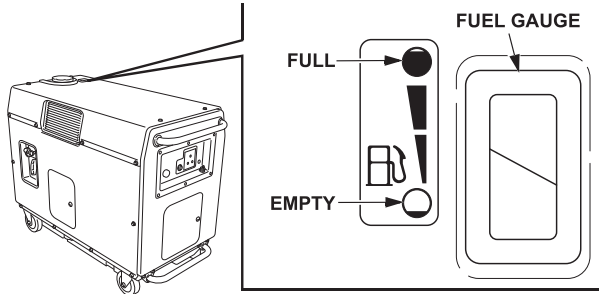

Wheel Stopper

Raise the stopper lever and slide it in the direction of the arrow so that it enters the hole in the wheel hole and then lower the stopper lever. Confirm that the wheel is locked.

The generator may become unstable if all four wheels are not firmly on the ground. Confirm that all four wheels are firmly on the ground before operation.

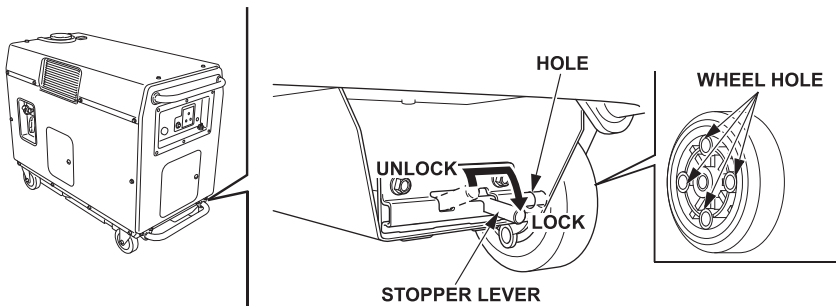

CONTROLS & FEATURES

FEATURES

Oil Alert System

The Oil Alert system is designed to prevent engine damage caused by an insufficient amount of oil in the crankcase. Before the oil level in the crankcase can fall below a safe limit, the Oil Alert system will automatically stop the engine (the engine switch will remain in the ON position).

If the engine stops and will not restart, check the engine oil level (see page 35) before troubleshooting in other areas.

Ground Terminal

The ground terminal is connected to the frame of the generator and the ground terminal of the receptacle.

Be sure to ground the generator when the connected appliance is grounded.

To ground the terminal of the generator, use a copper wire with same or larger diameter than the cord of the connected appliance.

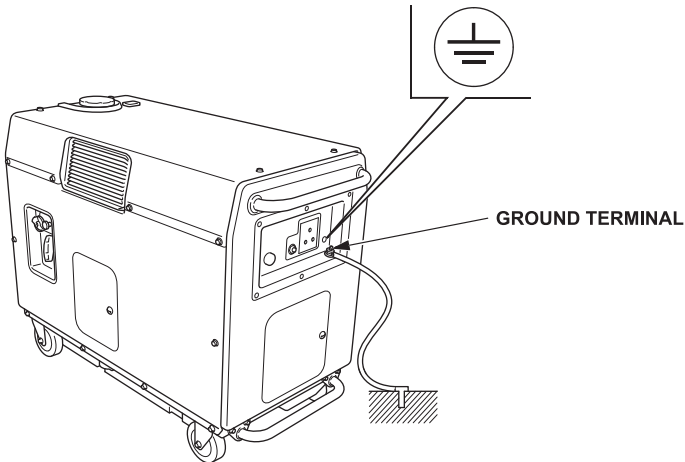

BEFORE OPERATION

ARE YOU READY TO GET STARTED?

Your safety is your responsibility. A little time spent in preparation will significantly reduce your risk of injury.

Knowledge

Read and understand this manual. Know what the controls do and how to operate them.

Familiarize yourself with the generator and its operation before you begin using it. Know how to quickly shut off the generator in case of an emergency.

If the generator is being used to power appliances, be sure that they do not exceed the generator's load rating (see page 27).

IS YOUR GENERATOR READY TO GO?

For your safety, to ensure compliance with environmental regulations, and to maximize the service life of your equipment, it is very important to take a few moments before you operate the generator to check its condition. Be sure to take care of any problem you find, or have your authorized Honda servicing dealer correct it, before you operate the generator.

WARNING

Improperly maintaining this generator, or failing to correct a problem before operation, could cause a malfunction in which you could be seriously injured.

Always perform a pre-operation inspection before each operation, and correct any problem.

BEFORE OPERATION

To prevent a possible fire, keep the generator at least 1 meter away from building walls and other equipment during operation. Do not place flammable objects close to the engine.

Before beginning your pre-operation checks, be sure the generator is on a level surface and the engine switch is in the OFF position.

NOTICE

Operating this generator less than 1 meter from a building or other obstruction can cause overheating and damage the generator. For proper cooling, allow at least 1 meter of empty space above and around the generator.

Check the Engine

- Before each use, look around and underneath the engine for signs of oil or petrol leaks.
- Check the oil level (see page 35). A low oil level will cause the Oil Alert system to shut down the engine.
- Check the air filters (see page 39). Dirty air filters will restrict air flow to the carburetor, reducing engine and generator performance.
- Check the fuel level (see page 33). Starting with a full tank will help to eliminate or reduce operating interruptions for refueling.

OPERATION

SAFE OPERATING PRECAUTIONS

Before operating the generator for the first time, review chapters *GENERATOR SAFETY* (see page 5) and *BEFORE OPERATION* (see page 19).

For your safety, do not operate the generator in an enclosed area such as a garage. Your generator's exhaust contains poisonous carbon monoxide gas that can collect rapidly in an enclosed area and cause illness or death.

WARNING

Exhaust contains poisonous carbon monoxide gas that can build up to dangerous levels in closed areas. Breathing carbon monoxide can cause unconsciousness or death.

Never run the generator in a closed, or even partly closed area where people may be present.

Before connecting an AC appliance or power cord to the generator:

- Use grounded 3 prong extension cords, tools, and appliances, or double insulated tools and appliances.
- Inspect cords and plugs, and replace if damaged.
- Make sure that the appliance is in good working order. Faulty appliances or power cords can create a potential for electric shock.
- Make sure the electrical rating of the tool or appliance does not exceed the rated power of the generator or the receptacle being used.
- Operate the generator at least 1 meter away from buildings and other equipment.
- Do not operate the generator in an enclosed structure.
- Do not place flammable objects close to the engine.

OPERATION

STARTING THE ENGINE

Refer to *SAFE OPERATING PRECAUTIONS* on page 21 and perform the *IS YOUR GENERATOR READY TO GO?* checks (see page 19).

Electric starter (EX2400S only):

1. Make sure that all appliances connected to the generator are turned off. The generator may be hard to start if a load is connected.
2. Turn the fuel valve knob to the ON position.
3. Pull the choke knob to the CLOSED position to start a cold Engine.
Leave the choke knob in the OPEN position to restart a warm engine.
4. Turn the engine switch to the START position, and hold it there until the engine starts. When the engine starts, release the engine switch key, allowing the switch to return to the ON position.
If the engine fails to start within 5 seconds, release the key, and wait at least 10 seconds before operating the starter again.

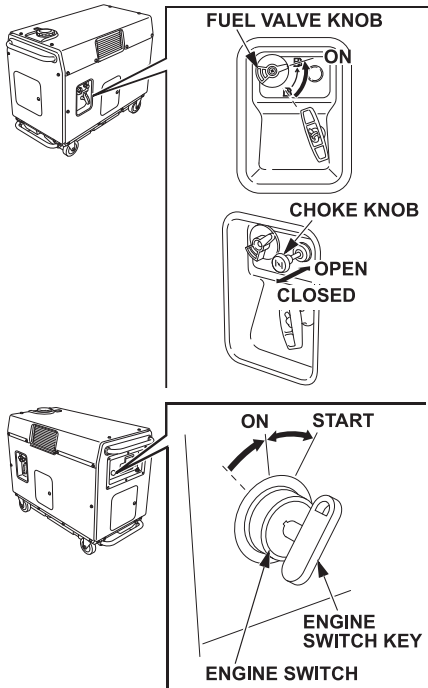

NOTICE

Using the electric starter for more than 5 seconds at a time will overheat the starter motor and can damage it.

Do not leave the engine switch in the ON position when the generator is not operating as the battery will get discharged. Turn the engine switch to the OFF position when not in use.

5. If the choke knob has been pulled to the CLOSED position to start the engine, gradually push it to the OPEN position as the engine warms up.

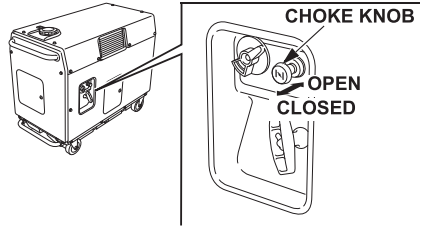

Recoil starter (EX2400 and EX2400S):

1. Make sure that all appliances connected to the generator are turned off. The generator may be hard to start if a load is connected.

2. Turn the fuel valve knob to the ON position.
3. Pull the choke knob to the CLOSED position to start a cold engine. Leave the choke knob in the OPEN position to restart a warm engine.

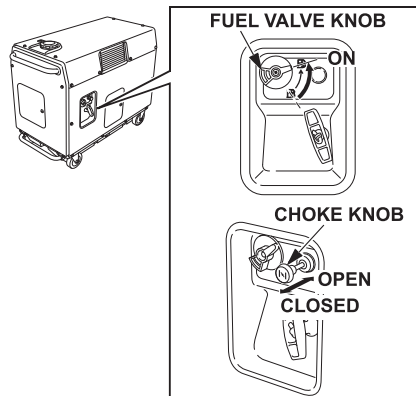

4. Turn the engine switch to the ON position.

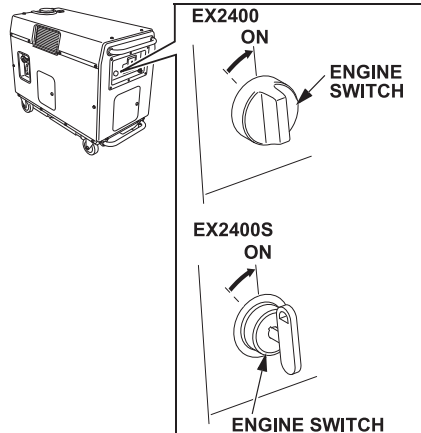

OPERATION

5. Pull the starter grip lightly until you feel resistance while holding the frame bar, then pull briskly in the direction of the arrow as shown.

NOTICE

- Do not allow the starter grip to snap back against the engine. Return it gently to prevent damage to the starter.
- Do not let the starter rope rub against the generator body, or the rope will wear out prematurely.

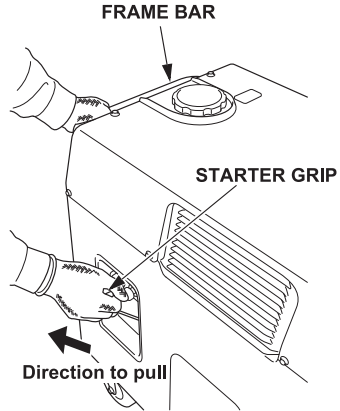

6. If the choke knob has been pulled to the CLOSED position to start the engine, gradually push it to the OPEN position as the engine warms up.

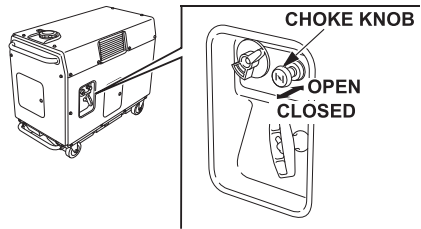

STOPPING THE ENGINE

To stop the engine in an emergency, simply turn the engine switch to the OFF position.

Under normal conditions, use the following procedure.

1. Turn off or disconnect all appliances connected to the generator.
2. Turn the engine switch to the OFF position.

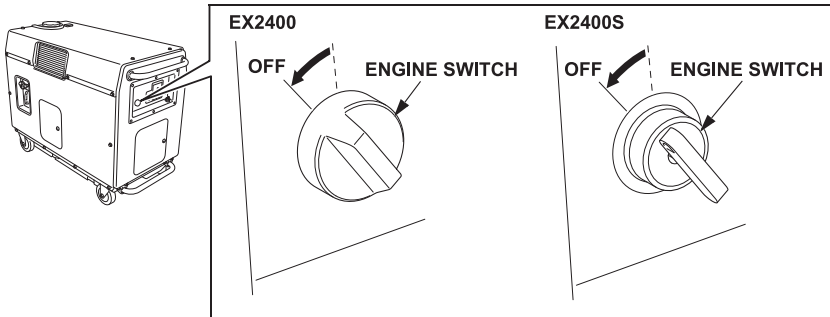

3. Turn the fuel valve knob to the OFF position.

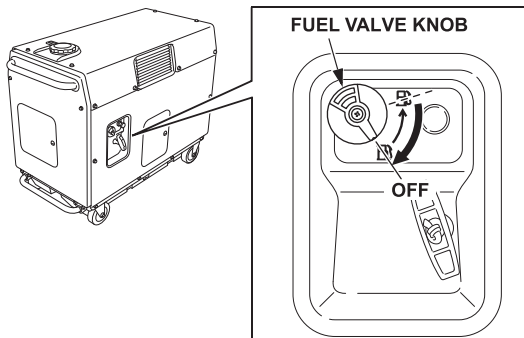

OPERATION

AC OPERATION

Before connecting an appliance to the generator, make sure that it is in good working order and that its electrical rating does not exceed that of the generator.

NOTICE

Substantial overloading may damage the generator. Marginal overloading may shorten the service life of the generator.

1. Start the engine (see page 22).
2. Plug an appliance into the appropriate AC receptacle.
Most motorized appliances require more than their rated wattage for startup.

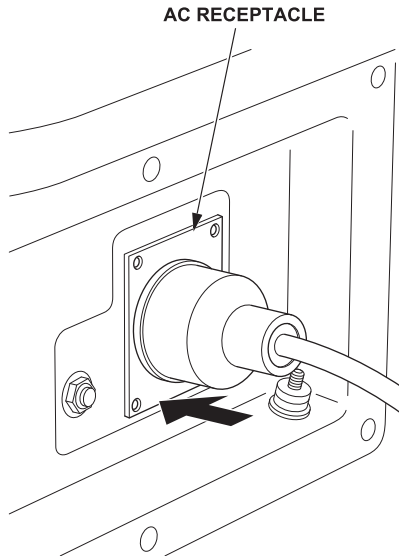

AC Applications

Before connecting an appliance or power cord to the generator:

- Make sure that it is in good working order. Faulty appliances or power cords can create a potential for electrical shock.
- If an appliance begins to operate abnormally, becomes sluggish, or stops suddenly, turn it off immediately. Disconnect the appliance, and determine whether the problem is the appliance or the rated load capacity of the generator has been exceeded.

Most appliance motors require more than their rated wattage for startup.

Make sure the electrical rating of the tool or appliance does not exceed the maximum power rating of the generator.

Maximum power is:

2.1 kVA

For continuous operation, do not exceed the rated power.

Rated power is:

1.8 kVA

In either case, the total power requirements (VA) of all appliances connected must be considered. Appliance and power tool manufacturers usually list rating information near the model number or serial number.

NOTICE

Substantial overloading will open the circuit protector. Slightly overloading the generator may not switch the circuit protector OFF, but will shorten the service life of the generator.

OPERATION

STANDBY POWER

Connections to a Building's Electrical System

Connections for standby power to a building's electrical system must be made by a qualified electrician . The connection must isolate the generator power from utility power, and must comply with all applicable laws and electrical codes.

WARNING

Improper connections to a building's electrical system can allow current from the generator to backfeed into the utility lines.

Such backfeed may electrocute utility company workers or others who contact the lines during a power outage, and the generator may explode, burn, or cause fires when utility power is restored.

Consult the utility company or a qualified electrician prior to making any power connections.

In some areas, generators are required by law to be registered with local utility companies. Check local regulations for proper registration and use procedures.

System Ground

This generator has a system ground that connects the generator frame components to the ground terminals in the AC output receptacles. The system ground is not connected to the AC neutral wire.

Special Requirements

There may be applicable laws, local codes, or ordinances that apply to the intended use of the generator. Please consult a qualified electrician, electrical inspector, or the local agency having jurisdiction.

- In some areas, generators are required to be registered with local utility companies.
- If the generator is used at a construction site, there may be additional regulations that must be observed.

SERVICING YOUR GENERATOR

THE IMPORTANCE OF MAINTENANCE

Good maintenance is essential for safe, economical, and trouble free operation. It will also help reduce air pollution.

To help you properly care for your generator, the following pages include a maintenance schedule, routine inspection procedures, and simple maintenance procedures using basic hand tools. Other service tasks that are more difficult or require special tools are best handled by professionals and are normally performed by a Honda technician or other qualified mechanic.

The maintenance schedule applies to normal operating conditions. If you operate your generator under unusual conditions, such as sustained high load or high temperature operation, or use it in dusty conditions, consult your authorized Honda servicing dealer for recommendations applicable to your individual needs and use.

WARNING

Improper maintenance, or failure to correct a problem before operation, can cause a malfunction in which you can be seriously hurt or killed.

Always follow the inspection and maintenance recommendations and schedules in this owner's manual.

Remember that an authorized Honda servicing dealer knows your generator best and is fully equipped to maintain and repair it.

To ensure the best quality and reliability, use only new, Honda Genuine parts or their equivalents for repair and replacement.

SERVICING YOUR GENERATOR

MAINTENANCE SAFETY

Some of the most important safety precautions follow. However, we cannot warn you of every conceivable hazard that can arise in performing maintenance. Only you can decide whether or not you should perform a given task.

WARNING

Failure to properly follow maintenance instructions and precautions can cause you to be seriously hurt or killed.

Always follow the procedures and precautions in the owner's manual.

Safety Precautions

Make sure the engine is off before you begin any maintenance or repairs. This will eliminate several potential hazards:

- **Carbon monoxide poisoning from engine exhaust.**
Operate outside away from open windows or doors.
- **Burns from hot parts.**
Let the engine and exhaust system cool before touching.
- **Injury from moving parts.**
Do not run the engine unless instructed to do so.
- Read the instructions before you begin, and make sure you have the tools and skills required.
- To reduce the possibility of fire or explosion, be careful when working around petrol. Use only a nonflammable solvent, not petrol, to clean parts. Keep cigarettes, sparks, and flames away from all fuel related parts.

SERVICING YOUR GENERATOR

MAINTENANCE SCHEDULE

REGULAR SERVICE PERIOD (3) Perform at every indicated month or operating hour interval, whichever comes first.		Each use	First month or 20 hrs.	Every 3 months or 50 hrs.	Every 6 months or 100 hrs.	Every year or 300 hrs.	Page	
ITEM								
Engine oil	Check level	o					35	
	Change		o		o		36	
Air cleaner	Check	o					39	
	Clean			o (1)			41	
	Replace					o*	40	
Spark plug	Check-adjust				o		42	
	Replace					o	42	
Valve clearance	Check-adjust					o (2)	-	
A.I. air filter	Clean					o (2)	-	
A.I. case drain	Drain					o (2)	-	
Combustion chamber	Clean	After every 500 hrs. (2)						-
Fuel tank and filter	Clean				o (2)		-	
Fuel tube	Check	Every 2 years (Replace if necessary) (2)						-

* Replace paper air filter only.

(1) Service more frequently when used in dusty areas.

(2) These items should be serviced by your authorized Honda servicing dealer, unless you have the proper tools and are mechanically proficient. Refer to the Honda shop manual for service procedures.

(3) For commercial use, log hours of operation to determine proper maintenance intervals.

This generator is equipped with a catalytic converter. If the engine is not properly maintained, the catalyst in the muffler may lose effectiveness.

SERVICING YOUR GENERATOR

REFUELING

With the engine stopped, remove the fuel tank cap and check the fuel level. Refill the fuel tank if the fuel level is low.

WARNING

Petrol is highly flammable and explosive.

You can be burned or seriously injured when handling fuel.

- Stop the engine and keep heat, sparks, and flame away.
- Handle fuel only outdoors.
- Wipe up spills immediately.

NOTICE

Fuel can damage paint and plastic. Be careful not to spill fuel when filling your fuel tank. Damage caused by spilled fuel is not covered under warranty.

Make sure that the wheel stopper is in the wheel hole and locked (see page 17).

Refuel in a well-ventilated area before starting the engine. If the engine has been running, allow it to cool. Refuel carefully to avoid spilling fuel. Do not fill the fuel tank above the upper limit mark (red) on the fuel filter.

Never refuel the engine inside a building where petrol fumes may reach flames or sparks. Keep petrol away from appliance pilot lights, barbecues, electric appliances, power tools, etc.

Spilled fuel is not only a fire hazard, it causes environmental damage. Wipe up spills immediately.

SERVICING YOUR GENERATOR

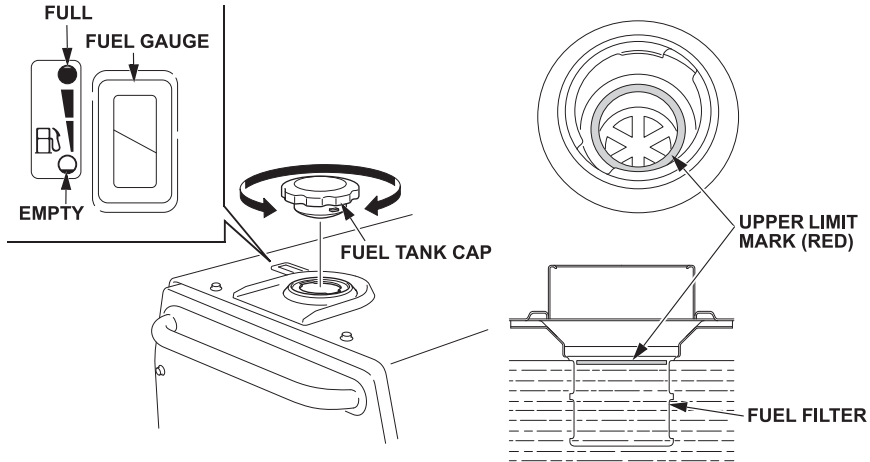

After refueling, reinstall the fuel tank cap securely.

FUEL RECOMMENDATIONS

Use unleaded petrol with a Research Octane Number of 91 or higher.

Use unleaded petrol only, or the catalyzer will loose its effectiveness and negatively affect exhaust emissions.

Never use stale or contaminated petrol or an oil/petrol mixture. Avoid getting dirt or water in the fuel tank.

You may use regular unleaded petrol containing ethanol 10% to 20% by volume.

Use of fuels with content of ethanol greater than shown above may cause starting and/or performance problems. It may also damage metal, rubber, and plastic parts of the fuel system.

Engine damage or performance problems that result from using a fuel with percentages of ethanol greater than shown above and leaded petrol are not covered under warranty.

If your equipment will be used on an infrequent or intermittent basis, please refer to the fuel section of the *STORAGE* chapter (see page 48) for additional information regarding fuel deterioration.

SERVICING YOUR GENERATOR

ENGINE OIL LEVEL CHECK

Check the engine oil level with the generator on a level surface and the engine stopped.

1. Make sure that the wheel stopper is in the wheel hole and locked (see page 17).
2. Open the front maintenance cover.
3. Remove the oil filler cap.

FRONT MAINTENANCE COVER

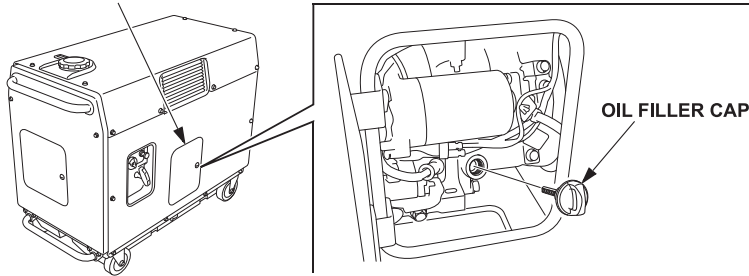

4. Check the oil level. If it is below the upper limit, fill with the recommended oil to the upper limit (see page 38).

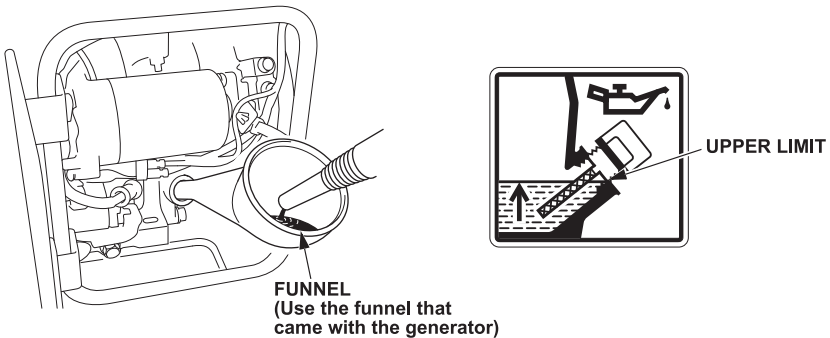

5. Reinstall the oil filler cap securely.
6. Close the front maintenance cover.

The Oil Alert system will automatically stop the engine before the oil level falls below safe limits. However, to avoid the inconvenience of an unexpected shutdown, check the oil level regularly.

SERVICING YOUR GENERATOR

ENGINE OIL CHANGE

Drain the oil while the engine is warm to assure rapid and complete draining.

Place the generator on a level surface with the engine stopped.

1. Make sure that the wheel stopper is in the wheel hole and locked (see page 17).
2. Place a suitable container underneath the drain cap (located below the front maintenance cover) to catch the used oil.
3. Remove the drain cap.
4. Open the front maintenance cover.

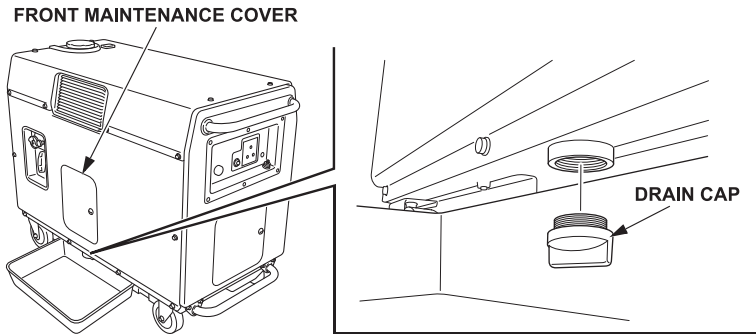

5. Remove the oil filler cap, oil drain plug and sealing washer and allow the used oil to drain completely.

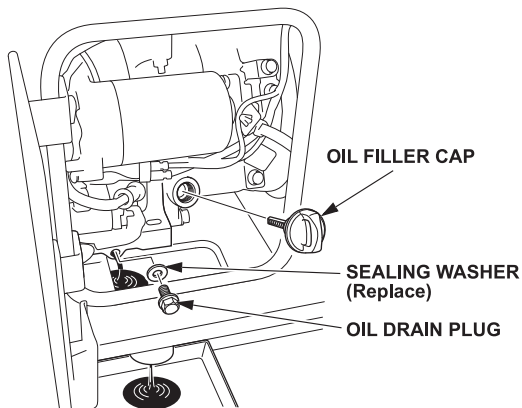

SERVICING YOUR GENERATOR

- Reinstall the oil drain plug, a new sealing washer and drain cap. Tighten the plug and cap securely.

NOTICE

Improper disposal of engine oil can be harmful to the environment. If you change your own oil, please dispose of the used oil properly. Put it in a sealed container, and take it to a recycling center. Do not discard it in a trash bin, dump it on the ground, or pour it down the drain.

- With the generator in a level position, fill with the recommended oil to the upper limit of the oil filler neck (see page 38).

Engine oil capacity: 0.58 L

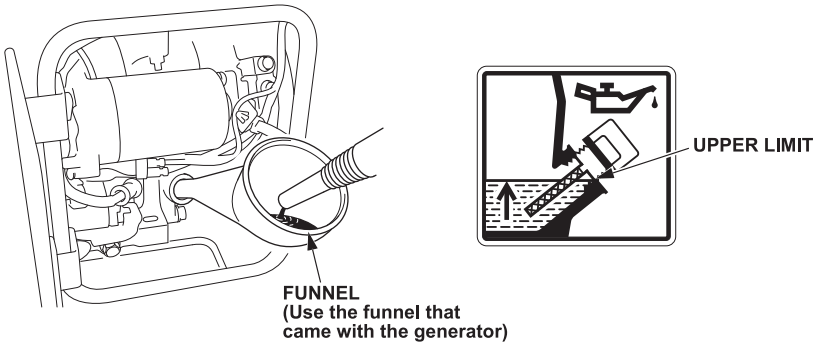

- Reinstall the oil filler cap securely.
 - Wipe off all the spilled oil from the generator.
 - Close the front maintenance cover.
- Wash your hands with soap and water after handling used oil.

SERVICING YOUR GENERATOR

ENGINE OIL RECOMMENDATIONS

Oil is a major factor affecting engine performance and service life. Use PRO HONDA GENUINE 4-STROKE Engine oil.

Use 4-stroke motor oil that meets or exceeds the requirements for API service category SF or later (or equivalent). Always check the API SERVICE label on the oil container to be sure it includes the letters SF or later (or equivalent).

SAE 10W-30 is recommended for general use. Other viscosities shown in the chart may be used when the average temperature in your area is within the recommended range.

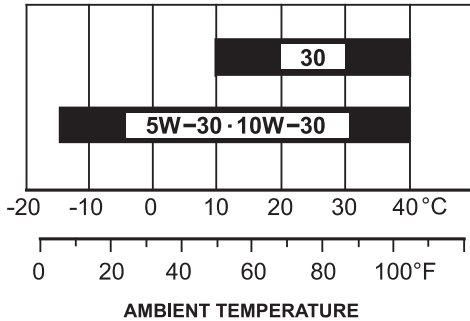

SERVICING YOUR GENERATOR

AIR CLEANER SERVICE

1. Open the left maintenance cover.
2. Unsnap the clips and remove the air cleaner cover.

LEFT MAINTENANCE COVER

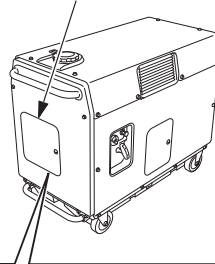

AIR CLEANER COVER

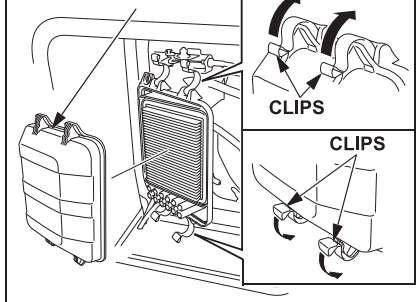

3. Check the foam air filter.
 - a. Remove the foam air filter from the air cleaner cover.
 - b. Check the foam air filter to be sure it is clean and in good condition.
If the foam air filter is dirty, clean it as described on page 41.
Replace the foam air filter if it is damaged.
 - c. Reinstall the foam air filter in the air cleaner cover.

AIR CLEANER COVER

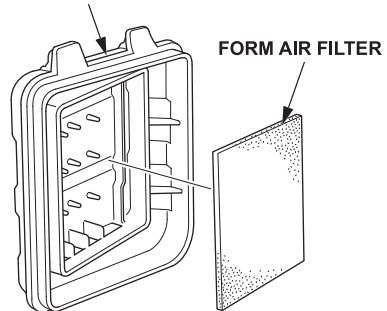

SERVICING YOUR GENERATOR

4. Check the paper air filter.
 - a. Remove the paper air filter from the air cleaner case. If the paper air filter is dirty, replace it with a new one. Do not clean the paper air filter.
 - b. Reinstall the paper air filter in the air cleaner case.

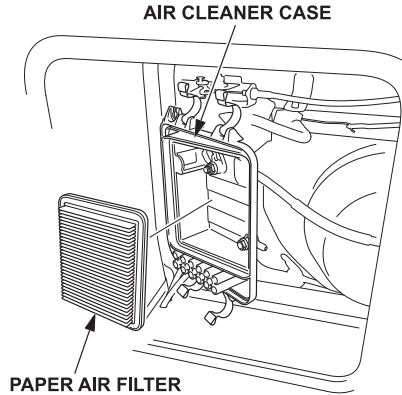

5. Install the air cleaner cover and snap the clips.
Be sure that the cover is set securely. There must be no clearance between the air cleaner cover and air cleaner case.
6. Close the left maintenance cover.

NOTICE

Operating the engine without the air filters, or with a damaged air filters, will allow dirt to enter the engine, causing rapid engine wear.

SERVICING YOUR GENERATOR

FOAM AIR FILTER CLEANING

A dirty air filter will restrict air flow to the carburetor, reducing engine performance. If you operate the generator in very dusty areas, clean the foam air filter more frequently than specified in the Maintenance Schedule.

1. Clean the foam air filter in warm soapy water, rinse, and allow to dry thoroughly, or clean in nonflammable solvent and allow to dry.
2. Dip the foam air filter in clean engine oil, then squeeze out all excess oil. The engine will smoke when started if too much oil is left in the foam air filter.

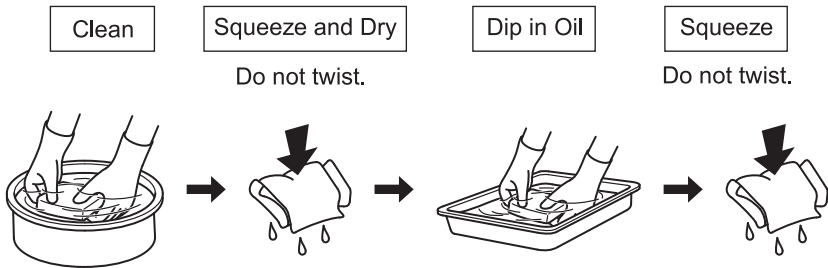

3. Wipe dirt from the inside of the air cleaner case and cover using a moist rag. Be careful to prevent dirt from entering the air duct that leads to the carburetor.

SERVICING YOUR GENERATOR

SPARK PLUG SERVICE

Recommended spark plug: BPR6ES (NGK)

NOTICE

An incorrect spark plug can cause engine damage.

1. Open the rear maintenance cover.
2. Disconnect the spark plug cap, and remove any dirt from around the spark plug area.
3. Remove the spark plug with a spark plug wrench.

REAR MAINTENANCE COVER

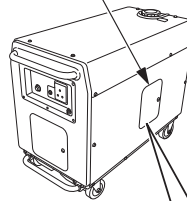

SPARK PLUG WRENCH

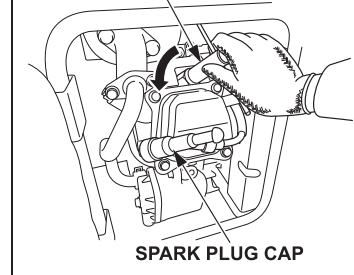

SPARK PLUG CAP

4. Inspect the spark plug. Replace it if the electrodes are worn or fouled, or if the insulator is cracked or chipped.
5. Measure the spark plug electrode gap with a wire type feeler gauge. Correct the gap, if necessary, by carefully bending the side electrode.

SIDE ELECTRODE

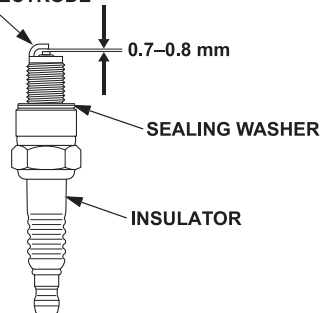

0.7-0.8 mm

SEALING WASHER

INSULATOR

The gap should be:
0.7-0.8 mm

6. Make sure that the spark plug sealing washer is in good condition, and thread the spark plug in by hand to prevent cross threading.

SERVICING YOUR GENERATOR

7. After the spark plug seats, tighten with a spark plug wrench to compress the washer.

If reinstalling a used spark plug, tighten 1/8–1/4 turn after the spark plug seats.

If installing a new spark plug, tighten 1/2 turn after the spark plug seats.

NOTICE

A loose spark plug can overheat and damage the engine.

Overtightening the spark plug can damage the threads in the cylinder head.

8. Attach the spark plug cap.

9. Close the rear maintenance cover.

SERVICING YOUR GENERATOR

BATTERY SERVICE (EX2400S only)

Your generator's engine charging system charges the battery while the engine is running. However, if the generator is only used periodically, the battery must be charged monthly to maintain the battery service life.

⚠ WARNING

The battery contains sulfuric acid (electrolyte), which is highly corrosive and poisonous. Getting electrolyte in your eyes or on your skin can cause serious burns.

Wear protective clothing and eye protection when working near the battery.
KEEP CHILDREN AWAY FROM THE BATTERY.

Emergency Procedures

Eyes – Flush with water from a cup or other container for at least fifteen minutes. (Water under pressure can damage the eye.) Call a physician immediately.

Skin – Remove contaminated clothing. Flush the skin with large quantities of water. Call a physician immediately.

Swallowing – Drink water or milk. Call a physician immediately.

SERVICING YOUR GENERATOR

Battery Removal

WARNING: Battery posts, terminals, and related accessories contain lead and lead compounds. **Wash hands after handling.**

1. Open the right maintenance cover.
2. Disconnect the negative (-) cable from the battery negative (-) terminal, and then disconnect the positive (+) cable from the battery positive (+) terminal.
3. Unhook the battery strap from the bottom hook of the generator.
4. Remove the battery.

RIGHT MAINTENANCE COVER

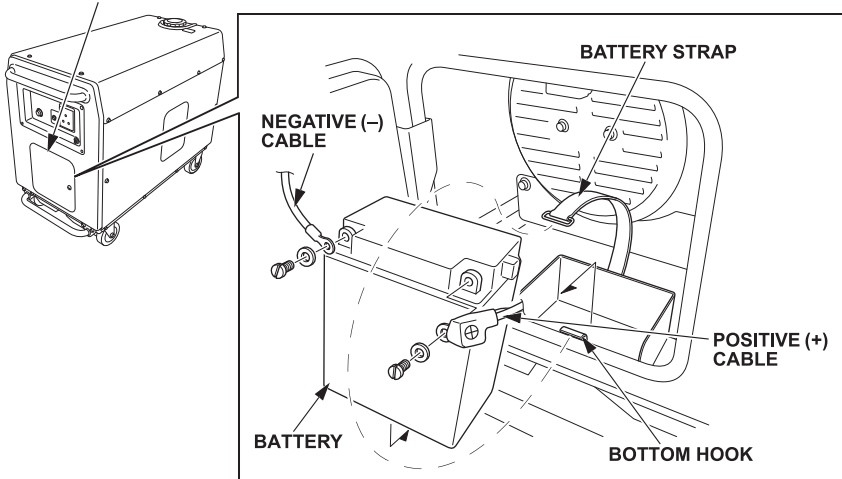

SERVICING YOUR GENERATOR

Battery Charging

⚠ WARNING

The battery gives off explosive hydrogen gas during normal operation.

A spark or flame can cause the battery to explode with enough force to kill or seriously hurt you.

Wear protective clothing and a face shield, or have a skilled mechanic perform the battery maintenance.

The battery is rated at 14.0 Ah (ampere-hours). Charging current should equal 10% of the battery's ampere-hour rating. A battery charger should be used that can be adjusted to deliver 1.4 amps.

1. Connect the battery charger following the manufacturer's instructions.
2. Charge the battery 5–10 hours.
3. Clean the outside of the battery and the battery compartment with a solution of baking soda and water.

Battery Installation

1. Install the battery into the generator.
2. Connect the positive (+) cable to the battery positive (+) terminal first, and tighten the bolt securely.
3. Slide the battery boot over the positive (+) cable and terminal.
4. Connect the negative (–) cable to the battery negative (–) terminal, and tighten the bolt securely.
5. Install the battery strap.
6. Close the right maintenance cover (see page 16).
Never operate the generator with the maintenance cover open, as poor engine and generator performance will result.

SERVICING YOUR GENERATOR

FUSE (EX2400S only)

If the fuse is blown, the starter motor will not operate.

In the event of fuse failure, locate the cause of failure and repair it before you continue operation. If the fuse continues to fail, discontinue generator use and consult an authorized Honda generator dealer.

1. Turn the engine switch to the OFF position and remove the key before checking or replacing the fuse.
2. Open the right maintenance cover.
3. Remove the fuse holder cover and pull the fuse out.

RIGHT MAINTENANCE COVER

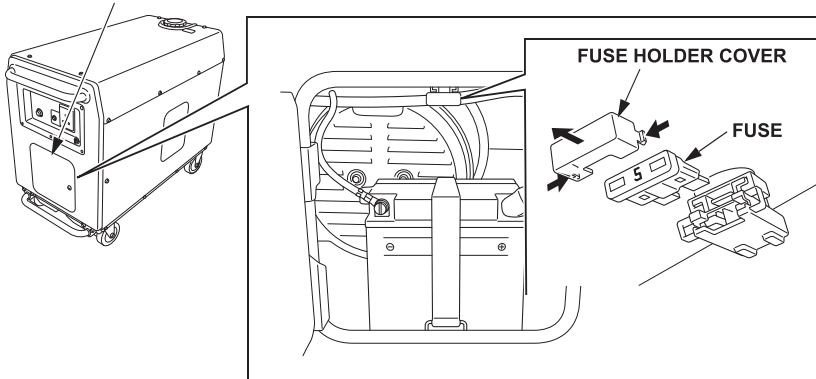

4. Replace the fuse with a fuse of the same type and rating.
Specified fuse: 5 A

NOTICE

Never use a fuse with a different rating from that specified. Serious damage to the electrical system or fire may result.

5. Install the fuse holder cover.
6. Close the right maintenance cover.

Never operate the generator with the maintenance cover open, as poor engine and generator performance will result.

STORAGE

STORAGE PREPARATION

Proper storage preparation is essential for keeping your generator trouble free and looking good. The following steps will help to keep rust and corrosion from impairing your generator's function and appearance, and will make the engine easier to start when you use the generator again.

Cleaning

Wipe the generator with a moist cloth. After the generator has dried, touch up any damaged paint, and coat other areas that may rust with a light film of oil.

Fuel

NOTICE

Depending on the region where you operate your equipment, fuel formulations may deteriorate and oxidize rapidly. Fuel deterioration and oxidation can occur in as little as 30 days and may cause damage to the carburetor and/or fuel system. Please check with your authorized Honda servicing dealer for local storage recommendations.

Petrol will oxidize and deteriorate in storage. Old petrol will cause hard starting, and it leaves gum deposits that clog the fuel system. If the petrol in your generator deteriorates during storage, you may need to have the carburetor and other fuel system components serviced or replaced.

The length of time that petrol can be left in your fuel tank and carburetor without causing functional problems will vary with such factors as petrol blend, your storage temperatures, and whether the fuel tank is partially or completely filled. The air in a partially filled fuel tank promotes fuel deterioration. Very warm storage temperatures accelerate fuel deterioration. Fuel deterioration problems may occur after 30 days from keeping the fuel in the fuel tank, or even less depending on the petrol formulation in your area.

STORAGE PROCEDURE

1. Drain the fuel tank and carburetor.

⚠ WARNING

Petrol is highly flammable and explosive.

You can be burned or seriously injured when handling fuel.

- Stop the engine and keep heat, sparks, and flame away.
- Handle fuel only outdoors.
- Wipe up spills immediately.

- a. Unscrew the fuel tank cap and remove the fuel filter.
- b. Drain all petrol from the fuel tank into an approved petrol container. We recommend using a commercially available petrol hand pump. Do not use an electric pump.

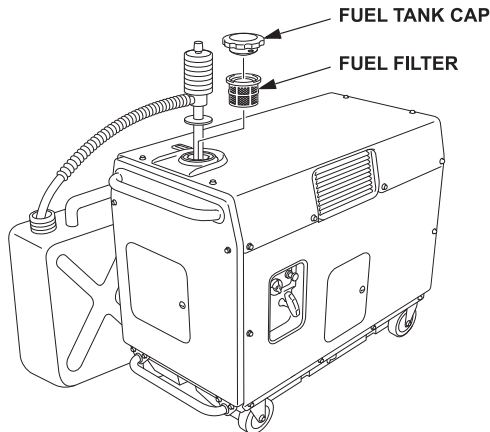

- c. Reinstall the fuel filter and the fuel tank cap.

STORAGE

- d. Open the rear maintenance cover (see page 16).
- e. Place a suitable container underneath the carburetor drain hose.
- f. Turn the fuel valve knob to the ON position (see page 22).
- g. Loosen the carburetor drain screw and drain the petrol from the carburetor into a suitable container.

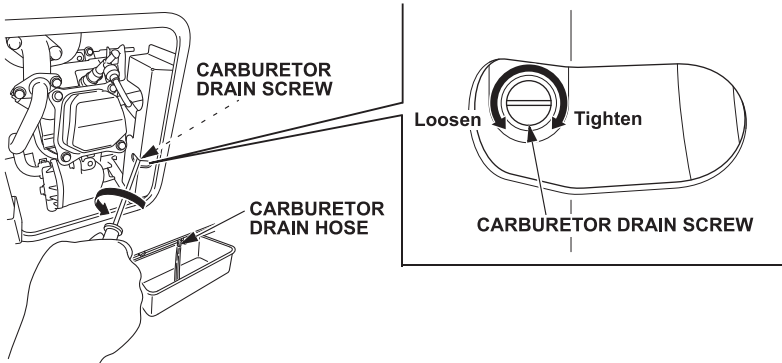

- h. After all fuel has drained into a suitable container, tighten the drain screw securely.
 - i. Turn the fuel valve knob to the OFF position (see page 25).
2. Change the engine oil (see page 36).
 3. Remove the spark plug (see page 42).
 4. Pour a teaspoon (5 cm³) of clean engine oil into the cylinder.
 5. Pull the starter rope several times to distribute the oil in the cylinder.
 6. Reinstall the spark plug.
 7. Close the rear maintenance cover (see page 16).
 8. Slowly pull the starter grip until resistance is felt. At this point, the piston is coming up on its compression stroke and both the intake and exhaust valves are closed. Storing the engine in this position will help to protect it from internal corrosion. Return the starter grip gently.
 9. EX2400S only: Charge the battery before storing the generator (see page 46).

STORAGE PRECAUTIONS

If your generator will be stored with petrol in the fuel tank and carburetor, it is important to reduce the hazard of petrol vapor ignition.

Select a well ventilated storage area away from any appliance that operates with a flame, such as a furnace, water heater, or clothes dryer. Also avoid any area with a spark-producing electric motor, or where power tools are operated.

If possible, avoid storage areas with high humidity, because that promotes rust and corrosion.

Unless all fuel has been drained from the fuel tank, leave the fuel valve knob in the OFF position to reduce the possibility of leakage.

Place the generator on a level surface. Tilting can cause fuel or oil leakage.

With the engine and exhaust system cool, cover the generator to keep out dust. A hot engine and exhaust system can ignite or melt some materials.

Do not use sheet plastic as a dust cover. A nonporous cover will trap moisture around the generator, promoting rust and corrosion.

EX2400S only: Fully charge the battery. Recharge the battery once a month (see page 46).

REMOVAL FROM STORAGE

Check your generator as described in the *BEFORE OPERATION* chapter of this manual (see page 19).

If the fuel was drained during storage preparation, fill the tank with fresh petrol. If you keep a container of petrol for refueling, be sure that it contains only fresh petrol. petrol oxidizes and deteriorates over time, causing hard starting.

If the cylinder was coated with oil during storage preparation, the engine may smoke briefly at startup. This is normal.

TRANSPORTING

BEFORE TRANSPORTING

1. Make sure the engine switch, fuel valve are OFF (see page 25).
2. Drain all petrol from the fuel tank, tighten the fuel tank cap securely (see page 49).

WARNING

Petrol is highly flammable and explosive.

You can be burned or seriously injured when handling fuel.

- Stop the engine and keep heat, sparks, and flame away.
- Handle fuel only outdoors.
- Wipe up spills immediately.

WHEN TRANSPORTING THE GENERATOR

If the generator has been running, allow the engine to cool down before loading the generator on the vehicle.

A hot engine and exhaust system can burn you and can ignite some materials.

Do not load the generator on a vehicle to transport with the fuel filled. The fuel may leak due to vibration during transport.

When transporting the generator, turn the engine switch and the fuel valve knob OFF, and Keep the generator level to reduce the possibility of fuel leakage.

Avoid a place exposed to direct sunlight when putting the generator on a vehicle. If the generator is left in an enclosed vehicle for many hours, high temperature inside the vehicle could cause fuel to vaporize resulting in a possible explosion.

Do not drive on a rough road for an extended period with the generator on board.

Transporting the Generator by Truck

Load the generator on a place where it will not drop off, tumble over or be damaged and tie it up with ropes or tie down straps.

Make sure that the wheel stopper is in the wheel hole and locked (see page 17).

When using ropes or tie down straps to secure the generator for transportation, only use the frame bars as attachment points, by protecting them with protective cloths or equivalent.

Do not fasten ropes or straps to any other portions of the generator body.

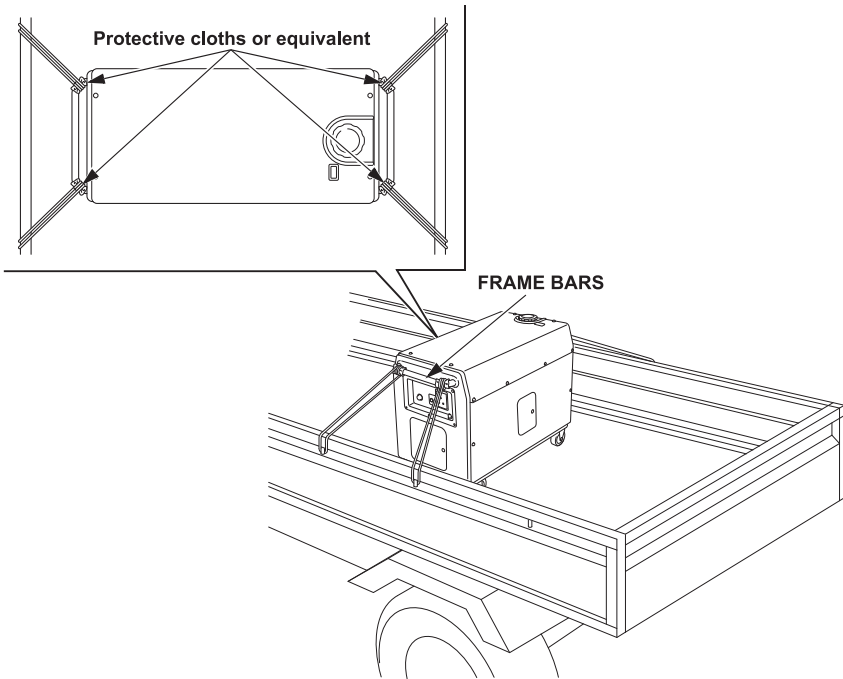

TAKING CARE OF UNEXPECTED PROBLEMS

ENGINE PROBLEMS

Engine Will Not Start

Possible Cause	Correction
Fuel valve OFF.	Turn fuel valve knob to the ON position (see page 13).
Choke OPEN.	Move choke knob to the CLOSED position unless engine is warm (see page 13).
Engine switch OFF.	Turn engine switch to the ON position (see page 14).
Out of fuel.	Refuel (see page 33).
Bad fuel; generator stored without draining petrol, or refueled with bad petrol.	Drain fuel tank and carburetor (see page 49). Refuel with fresh petrol (see page 33).
Low oil level caused Oil Alert to stop engine.	Add oil (see page 35). Restart the engine.
Spark plug faulty, fouled, or improperly gapped.	Gap, or replace spark plug (see page 42).
Spark plug wet with fuel (flooded engine).	Dry and reinstall spark plug.
Fuel filter restricted, carburetor malfunction, ignition malfunction, valves stuck, etc.	Take generator to your authorized Honda servicing dealer, or refer to shop manual.

Engine Lacks Power

Possible Cause	Correction
Air filter restricted.	Clean or replace air filter (see pages 39 through 41).
Bad fuel; generator stored without draining petrol, or refueled with bad petrol.	Drain fuel tank and carburetor (see page 49). Refuel with fresh petrol (see page 33).
Fuel filter restricted, carburetor malfunction, ignition malfunction, valves stuck, etc.	Take generator to your authorized Honda servicing dealer, or refer to shop manual.

TAKING CARE OF UNEXPECTED PROBLEMS

GENERATOR PROBLEMS

No Power at the AC Receptacle

Possible Cause	Correction
AC circuit protector tripped.	Check AC load and reset circuit protector (see page 15).
Faulty power tool or appliance.	Replace or repair power tool or appliance. Stop and restart the engine.
Faulty generator.	Take generator to your authorized Honda servicing dealer, or refer to shop manual.

TECHNICAL INFORMATION

SERIAL NUMBER LOCATIONS

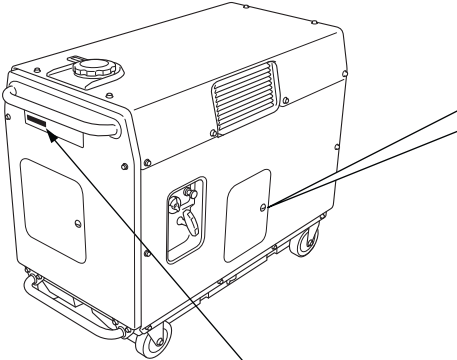

FRAME SERIAL NUMBER

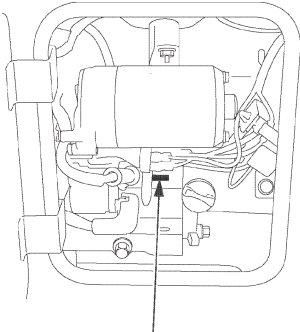

ENGINE SERIAL NUMBER

CARBURETOR MODIFICATION FOR HIGH ALTITUDE OPERATION

At high altitude, the standard carburetor air fuel mixture will be too rich. Performance will decrease, and fuel consumption will increase. A very rich mixture will also foul the spark plug and cause hard starting. Operation at an altitude that differs from that at which this engine was certified, for extended periods of time, may increase emissions.

High altitude performance can be improved by specific modifications to the carburetor. If you always operate your generator at altitudes above 610 meters, have your authorized Honda servicing dealer perform this carburetor modification.

Even with carburetor modification, engine horsepower will decrease about 3.5% for each 300 meter increase in altitude. The effect of altitude on horsepower will be greater than this if no carburetor modification is made.

NOTICE

When the carburetor has been modified for high altitude operation, the air/fuel mixture will be too lean for low altitude use. Operation at altitudes below 610 meters with a modified carburetor may cause the engine to overheat and result in serious engine damage. For use at low altitudes, have your authorized Honda servicing dealer return the carburetor to original factory specifications.

TECHNICAL INFORMATION

SPECIFICATIONS

Dimensions

Model	EX2400	EX2400S
Description code	EELD	EEMD
Length	985 mm	
Width	471 mm	
Height	722 mm	
Dry mass (weight)	84.4 kg	91.8 kg

Engine

Model	GX160D
Engine type	4-stroke, overhead valve, single cylinder
Displacement	163 cm ³
Bore×Stroke	68.0×45.0 mm
Cooling system	Forced air
Ignition system	Transistorized magneto ignition
Engine oil capacity	0.58 L
Fuel tank capacity	9.4 L
Spark plug	BPR6ES (NGK)

Generator

	Model	EX2400	EX2400S
AC output	Rated voltage	230 V	
	Rated frequency	50 Hz	
	Rated ampere	7.8 A	
	Rated output	1.8 kVA	
	Max output	2.1 kVA	

Specifications may vary according to the types, and are subject to change without notice.

WARRANTY POLICY

1. INTRODUCTION

- Warranty is an assurance to the customer of a quality product. Honda warrants all its GENERATOR models to be free from any manufacturing defect. In the event of failure, any Honda authorised dealer will repair or replace, free of charge, any part of the set as per norms laid down by the company. The company's decision shall be final and binding.

2. WARRANTY PERIOD

GENERATOR

- Two years from the date of purchase for Non-commercial use by customer.
- Two years from the date of purchase for Commercial/Rental use by customer.

BATTERY (Proprietary Part)

- Six months from the date of purchase by customer.
- Final decision of Warranty at the sole discretion of EXIDE / Authorised EXIDE Dealer.

3. WARRANTY OBLIGATION

- Repair or replacement of defective part(s), at any authorised dealer, free of charge, if found defective by reasons of defective material or poor workmanship.

4. WARRANTY SERVICE

- To obtain warranty service the complete set must be presented to any of authorised dealer service point at customer's risk and expense.

5. TERMS AND CONDITIONS

- a. To qualify for warranty, Honda generator must be set-up and serviced by an authorised Honda dealer.
 - b. Presentation of this warranty & free service coupon booklet.
 - c. Warranty does not include :
 1. Normal/natural wear & tear and normal deterioration of paint or other appearances.
 2. Failures resulting from unauthorised modifications or repairs.
 3. Failures resulting due to not availing of free service within the stipulated time.
 4. Rubber parts , Hardware items like Nuts & Bolts, Element Air Cleaner, Filters, Electrical Wires, Spark Plug, Gaskets, Starter Rope, Oil and petrol.
 5. Damages or failures resulting from misuse, operational faults, negligence, abnormal use, insufficient care, over-loading, accident or fire from external source, theft, chemical fall out, stone chipping, industrial pollution, transportation.
 6. Failures due to usage of non recommended or adulterated engine oil and fuel. Failures due to usage of mixture of engine oil and fuel.
 7. Normal phenomena such as noise and vibrations.
 8. Incidental or consequential damages like inconvenience or commercial loss.
 9. Any part or labour incurred in normal maintenance services.
 10. Failures resulting from usage of non genuine spare part (s).
- Note : All disputes are subject to jurisdiction of Delhi court only.

INSTALLATION AND FREE SERVICES

1. PRE-INSTALLATION CHECK (P.I.C.)

- A pre delivery inspection is provided by Honda dealer so that you can enjoy longer trouble free Generator life.
- P.I.C. coupon is attached herewith.

2. PERIODIC MAINTENANCE SERVICE

- To enhance trouble free Generator life, periodic maintenance must be carried out as per maintenance schedule given in the owner's manual.

3. FREE SERVICE

- Three free service coupons are attached.
- Customer is requested to bring the Generator to any authorised dealer/ service point alongwith this booklet for availing free service.
- Free service can be availed at any of the authorised dealer / service point.
- This offer is valid only for the free services as per the schedule given in the chart below.

Type of Service	Schedule (from date of P.I.C.)		Other Details
	Days	Cum. operational hours	
Service I	30	20	Labour free but consumables chargeable to the customer
Service II	90	50	
Service III	180	100	

Honda India Power Products Limited

Head Office: Plot No. 5, Sector-41, Kasna, Greater Noida Industrial Development Area,
Distt. Gautam Budh Nagar - 201310, Uttar Pradesh.

Tel.: 0120-2590100

LIST OF AREA OFFICES

AHMEDABAD

A-904, Siddhi Vinayak Tower,
B/H DCP Office, Opp. S.G. Highway,
Makarba, Ahmedabad - 38005, Gujarat.
Tel. : 079-48000730, 9978912986
E-mail : ao.ahm@hipp.co.in

BENGALURU

Solus D-07, 7th Floor, 1st Cross, J.C. Road,
Opp. Bengaluru Stock Exchange,
Bengaluru - 560027, Karnataka.
Tel. : 080-22217152
E-mail : ao.blr@hipp.co.in

BHOPAL

10A, Samath Complex, 2nd Floor,
Opp. M.P. Board Office,
Link Road No. 1, Shivaji Nagar,
Bhopal - 462016, Madhya Pradesh.
Tel. : 0755-4258515
E-mail : ao.bho@hipp.co.in

BHUBANESWAR

Plot No. 62-63, Unit - 6, Ganganagar,
Bhubaneswar - 751001, Odisha.
Tel. : 0674-2397352, 2397477
E-mail : ao.bhu@hipp.co.in

CHANDIGARH

Metro Plaza City Market, 1st Floor,
SCO-27, Lohagarh Road, Zirakpur,
SAS Nagar - 140603, Punjab.
Tel. : 01762-531109
E-mail : ao.chd@hipp.co.in

CHENNAI

1st Floor of Old No. 79, New No. 13,
Coundamani Flats, Bhaskar Colony,
Virugambakkam,
Chennai - 600092, Tamil Nadu.
Tel. : 044-23767091, 23767092
E-mail : ao.mad@hipp.co.in

COCHIN

Door No. 44/2214 D3, 2nd Floor,
Holy Tuesday Shopping Mall, Kaloor,
Kochi - 685017, Kerala.
Tel. : 0484-2537753, 2537763
E-mail : ao.coch@hipp.co.in

RANCHI

Raghav Kunj, Goyal Road,
Opp. Goyal Sanitary,
Near Kishoreganj Chowk,
Ranchi - 834001, Jharkhand.
Tel. : 0651-2214230
E-mail : ao.ranchi@hipp.co.in

GUWAHATI

Space no.- 306-307, 3rd.Floor,
Silver Oak Plaza, Near Sarusajai Stadium,
Lokhra, NH-37,
Guwahati - 781034, Assam.
Tel. : 1800-11-2323
E-mail: ao.guw@hipp.co.in

HYDERABAD

Plot No.48, 2nd Floor,
Above Indian Overseas Bank,
West Marredpally,
Secunderabad - 500026, Telangana.
Tel. : 040-27803449, 27803450
E-mail: ao.hyd@hipp.co.in

JAMMU

Plot No. 50, Yard No. 6, Near SRTC Yard,
Transport Nagar, Narwal,
Jammu - 180006, J&K (UT).
Tel. : 0191-2490058
E-mail: ao.jmu@hipp.co.in

KOLKATA

15th Floor, Unit No 1503,
Ergo Tower, Salt Lake, Sector - 5,
Kolkata - 700091, West Bengal.
Tel. : 033-48080030
E-mail: ao.cal@hipp.co.in

LUCKNOW

80, Chandralok Colony, Aliganj,
Lucknow - 226204, Uttar Pradesh.
Tel. : 1800-11-2323
E-mail: ao.luk@hipp.co.in

MUMBAI

A-212, 2nd Floor, Sagar Tech Plaza,
Sakinaka, Andheri (E),
Mumbai - 400072, Maharashtra.
Tel. : 022-28511342, 28513874, 46043223
E-mail: ao.mum@hipp.co.in

DELHI

Plot No. 5, Sector - 41, Kasna,
Greater Noida Industrial Development Area,
Gautam Budh Nagar - 201310, Uttar Pradesh.
Tel. : 0120-2590244
E-mail: ao.del@hipp.co.in

DISPOSAL

To protect the environment, do not dispose off the used generator, battery, engine oil, etc. carelessly by leaving them in the waste. Observe the local laws or regulations or consult your authorized Honda generator dealer to dispose off these parts.

Please dispose off used engine oil in a manner that is compatible with the environment. We suggest you take it in a sealed container to your local service station for reclamation. Do not throw it in the trash or pour it on the ground.

An improperly disposed battery (only EX2400S) can hurt the environment. Always confirm local regulations for battery disposal. Contact your servicing dealer for replacement.

Pro Honda

Genuine Lubes & Chemicals

Fully Synthetic Engine Oil



Honda developed PRO HONDA to maximize performance of every Honda engine.



Enhances Performance



Ensures Longer Engine Life



Meeting International Quality Standards

Available in
20 L
1.2 L
600 ml
350 ml

Best fit for your Power Products and Outboard motors



GENERATOR



WATER PUMP



LAWN MOWER



BRUSH CUTTER



TILLER



ENGINE



OUTBOARD MOTOR

HONDA



Honda India Power Products Limited

Regd. Off.: 409, DLF Tower B,
Jasola Commercial Complex,
New Delhi -110 025.

E-mail : ho.mktg@hipp.co.in

Website : www.hondaindiapower.com

To access information about
Operations, Maintenance &
Troubleshooting, please visit:
www.hppsv.com/IND/ or scan



© Honda India Power Products Ltd. 2025

Ⓜ XXX.XXXXXX

Printed in XXXXX

4MZ38804

00X4M-Z38-8040