

# HONDA

## GENERATOR EP1000

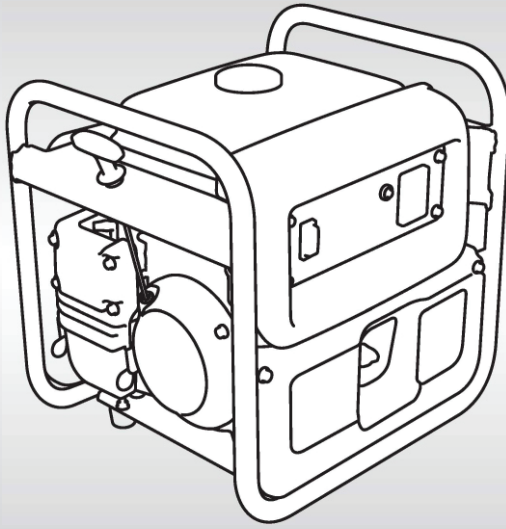

### OWNER'S MANUAL

ग्राहक पुस्तिका

Honda India Power Products Limited

होण्डा इंडिया पॉवर प्रोडक्ट्स लिमिटेड



Need Help?

Call Toll Free

1800-11-2323

**Honda EP1000**

**OWNER'S MANUAL**

**ग्राहक पुस्तिका**

Keep this owner's manual handy so that you can refer to it at any time. This owner's manual is considered a permanent part of the generator and should remain with the generator if resold.

The information and specifications included in this publication were in effect at the time of approval for printing. Honda India Power Products Ltd. reserves the right, however, to discontinue or change specifications or design at any time without notice and without incurring any obligation whatsoever.

Honda Selling Dealer		
Name :	_____	
Address :	_____ _____	
Tel. No. :	_____	
P. I. C. Date :	_____	
Warranty valid upto :	_____	
Usage Type :	Commercial <input type="checkbox"/>	Non-commercial <input type="checkbox"/> Rental <input type="checkbox"/>

# INTRODUCTION

Congratulations on your selection of a Honda generator. We are certain you will be pleased with your purchase of one of the finest generators in the market.

We want to help you get the best results from your new generator and to operate it safely. This manual contains all the information on how to do that; please read it carefully.

As you read this manual, you will find information preceded by a **NOTICE** symbol. That information is intended to help you avoid damage to your generator, other property, or the environment.

We suggest you read the warranty policy to fully understand its coverage and your responsibilities of ownership.

When your generator needs scheduled maintenance, keep in mind that your Honda servicing dealer is specially trained in servicing Honda generators. Your authorized Honda servicing dealer is dedicated to your satisfaction and will be pleased to answer your questions and concerns.

We welcome your valuable suggestions & feedback.

Kindly send your feedback to Marketing Manager:



**or else**

contact our Customer Care Centre for Support :

Best Wishes,  
Honda India Power Products Ltd.

Honda India Power Products Limited  
Phone No.: 0120-2590100  
e-mail : ho.mktg@hipp.co.in  
Working Hours : 08:15 A.M. to 05:15 P.M. (Mon to Fri)

Toll Free No. : **1800 11 2323**  
Working Hours : 09:00 A.M. to 07:00 P.M.  
(Available Monday to Sunday except on Public Holidays)

To access information about Operations, Maintenance & Troubleshooting, please visit: [www.hppsv.com/IND/](http://www.hppsv.com/IND/) or scan  

# INTRODUCTION

---

## A FEW WORDS ABOUT SAFETY

Your safety and the safety of others are very important. And using this generator safely is an important responsibility.

To help you make informed decisions about safety, we have provided operating procedures and other information on labels and in this manual. This information alerts you to potential hazards that could hurt you or others.

Of course, it is not practical or possible to warn you about all the hazards associated with operating or maintaining a generator. You must use your own good judgement.

You will find important safety information in a variety of forms, including:

- **Safety Labels**– on the generator.
- **Safety Messages**– preceded by a safety alert symbol  and one of three signal words, DANGER, WARNING, or CAUTION.

These signal words mean:

 **DANGER**

You **WILL** be **KILLED** or **SERIOUSLY HURT** if you don't follow instructions.

 **WARNING**

You **CAN** be **KILLED** or **SERIOUSLY HURT** if you don't follow instructions.

 **CAUTION**

You **CAN** be **HURT** if you don't follow instructions.

- **Safety Headings**– such as *IMPORTANT SAFETY INFORMATION* .
- **Safety Section**– such as *GENERATOR SAFETY*.
- **Instructions**– how to use this generator correctly and safely.

This entire book is filled with important safety information – please read it carefully.

# CONTENTS

<b>GENERATOR SAFETY .....</b>	<b>5</b>
<b>IMPORTANT SAFETY INFORMATION.....</b>	<b>5</b>
Operator Responsibility .....	5
Carbon Monoxide Hazards .....	5
Electric Shock Hazards.....	6
Fire and Burn Hazards .....	6
Refuel With Care .....	7
<b>SAFETY LABEL LOCATION .....</b>	<b>8</b>
<b>CONTROLS &amp; FEATURES .....</b>	<b>11</b>
<b>COMPONENT &amp; CONTROL LOCATIONS .....</b>	<b>11</b>
<b>CONTROLS .....</b>	<b>13</b>
Fuel Valve .....	13
Choke Lever .....	13
Engine Switch.....	14
Starter Grip.....	14
AC Circuit Protector .....	15
<b>FEATURES .....</b>	<b>16</b>
Oil Alert System .....	16
Ground Terminal.....	16
<b>BEFORE OPERATION.....</b>	<b>17</b>
<b>ARE YOU READY TO GET STARTED? .....</b>	<b>17</b>
Knowledge .....	17
<b>IS YOUR GENERATOR READY TO GO?.....</b>	<b>17</b>
Check the Engine .....	18
<b>OPERATION.....</b>	<b>19</b>
<b>SAFE OPERATING PRECAUTIONS .....</b>	<b>19</b>
<b>STARTING THE ENGINE .....</b>	<b>20</b>
<b>STOPPING THE ENGINE .....</b>	<b>22</b>
<b>AC OPERATION .....</b>	<b>23</b>
AC Applications .....	24
<b>STANDBY POWER.....</b>	<b>25</b>
Connections to a Building's Electrical System .....	25
System Ground .....	25
Special Requirements .....	26

# CONTENTS

---

<b>SERVICING YOUR GENERATOR .....</b>	<b>27</b>
THE IMPORTANCE OF MAINTENANCE .....	27
MAINTENANCE SAFETY .....	28
Safety Precautions .....	28
MAINTENANCE SCHEDULE .....	29
REFUELING .....	30
FUEL RECOMMENDATIONS .....	31
ENGINE OIL LEVEL CHECK .....	32
ENGINE OIL CHANGE .....	33
ENGINE OIL RECOMMENDATIONS .....	35
AIR CLEANER SERVICE .....	36
AIR FILTER CLEANING .....	38
SPARK PLUG SERVICE .....	39
<b>STORAGE .....</b>	<b>41</b>
STORAGE PREPARATION .....	41
Cleaning .....	41
Fuel .....	41
STORAGE PROCEDURE .....	42
STORAGE PRECAUTIONS .....	44
REMOVAL FROM STORAGE .....	44
<b>TRANSPORTING .....</b>	<b>45</b>
BEFORE TRANSPORTING .....	45
WHEN TRANSPORTING THE GENERATOR .....	45
Transporting the Generator by Truck .....	46
Transporting the Generator by Hand .....	47
<b>TAKING CARE OF UNEXPECTED PROBLEMS .....</b>	<b>48</b>
Engine Will Not Start .....	48
Engine Lacks Power .....	48
No Power at the AC Receptacle .....	49
<b>TECHNICAL INFORMATION .....</b>	<b>50</b>
SERIAL NUMBER LOCATIONS.....	50
CARBURETOR MODIFICATION FOR HIGH ALTITUDE OPERATION .....	51
SPECIFICATIONS .....	52
<b>WARRANTY POLICY .....</b>	<b>53</b>
<b>INSTALLATION AND FREE SERVICES .....</b>	<b>54</b>
<b>LIST OF AREA OFFICES .....</b>	<b>55</b>

# GENERATOR SAFETY

## IMPORTANT SAFETY INFORMATION

Honda generators are designed for use with electrical equipment that has suitable power requirements. Other use can result in injury to the operator or damage to the generator and other property.

Most injuries or property damage can be prevented if you follow all instructions in this manual and on the generator. The most common hazards are discussed below, along with the best way to protect yourself and others.

### Operator Responsibility

- Know how to stop the generator quickly in case of emergency.
- Understand the use of all generator controls, output receptacles, and connections.
- Be sure that anyone who operates the generator receives proper instruction. Do not let children operate the generator without parental supervision.

### Carbon Monoxide Hazards

A generator's exhaust contains toxic carbon monoxide, which you cannot see or smell. Breathing carbon monoxide can **KILL YOU IN MINUTES**. To avoid carbon monoxide poisoning, follow these instructions when operating a generator:

- Only run a generator **OUTSIDE**, far away from windows, doors, and vents.
- Never operate a generator inside a house, garage, basement, crawl space, or any enclosed or partially enclosed space.
- Never operate a generator near open doors or windows.
- Get fresh air and seek medical attention immediately if you suspect you have inhaled carbon monoxide.

Early symptoms of carbon monoxide exposure include headache, fatigue, shortness of breath, nausea, and dizziness. Continued exposure to carbon monoxide can cause loss of muscular coordination, loss of consciousness, and then death.

# GENERATOR SAFETY

---

## Electric Shock Hazards

- The generator produces enough electric power to cause a serious shock or electrocution if misused.
- Do not use in wet conditions. Keep the generator dry.
  - Do not use in the rain or snow.
  - Do not use near a pool or sprinkler system.
  - Do not use when your hands are wet.
- If the generator is stored outdoors, unprotected from the weather, check all of the electrical components on the control panel before each use. Moisture or ice can cause a malfunction or short circuit in electrical components that could result in electrocution.
- Do not connect to a building's electrical system unless an isolation switch has been installed by a qualified electrician.

## Fire and Burn Hazards

- The exhaust system gets hot enough to ignite some materials.
  - Keep the generator at least 1 meter away from buildings and other equipment during operation.
  - Do not enclose the generator in any structure.
  - Keep flammable materials away from the generator.
- The muffler becomes very hot during operation and remains hot for a while after stopping the engine. Be careful not to touch the muffler while it is hot. Let the engine cool before storing the generator indoors.

# GENERATOR SAFETY

---

## **Refuel With Care**

Petrol is extremely flammable, and petrol vapor can explode.

Allow the engine to cool if the generator has been in operation.

Refuel only outdoors in a well-ventilated area with the engine off.

Do not refuel during operation.

Do not overfill the fuel tank.

Never smoke near petrol, and keep other flames and sparks away.

Always store petrol in an approved container.

Make sure that any spilled fuel has been wiped up before starting the engine.

# GENERATOR SAFETY

---

## SAFETY LABEL LOCATION

These labels warn you of potential hazards that can cause serious injury. Read them carefully. If a label comes off or becomes hard to read, contact your Honda servicing dealer for a replacement.

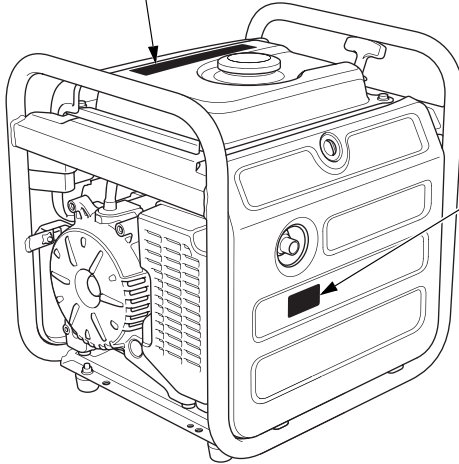

# GENERATOR SAFETY

---



- Honda generator is designed to give safe and dependable service if operated according to instructions.  
Read and understand the Owner's Manual before operating the generator. Failure to do so could result in personal injury or equipment damage.



- Exhaust contains poisonous carbon monoxide, a colorless, odorless gas. Breathing carbon monoxide can cause loss of consciousness and may lead to death.
- If you run the generator in an area that is confined, or even partially enclosed area, the air you breathe could contain a dangerous amount of exhaust gas.
- Never run your generator inside a garage, house or near open windows or doors.



- Petrol is highly flammable and explosive.  
Turn the engine off and let it cool before refueling.

# GENERATOR SAFETY

---



- Do not connect to a building's electrical system unless an isolation switch has been installed by a qualified electrician.
- Connections for standby power to a building's electrical system must be made by a qualified electrician and must comply with all applicable laws and electrical codes. Improper connections can allow electrical current from the generator to backfeed into the utility lines. Such backfeed may electrocute utility company workers or others who contact the lines during a power outage, and when utility power is restored, the generator may explode, burn, or cause fires in the building's electrical system.



- A hot exhaust system can cause serious burns. Avoid contact if the engine has been running.

# CONTROLS & FEATURES

## COMPONENT & CONTROL LOCATIONS

Use the illustrations on these pages to locate and identify the most frequently used controls.

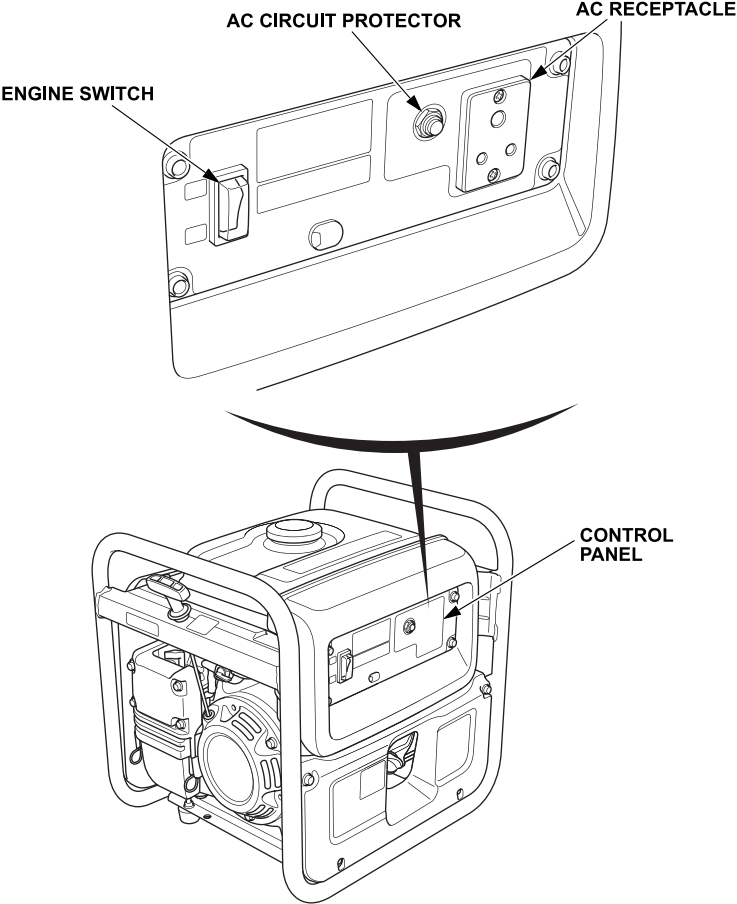

# CONTROLS & FEATURES

---

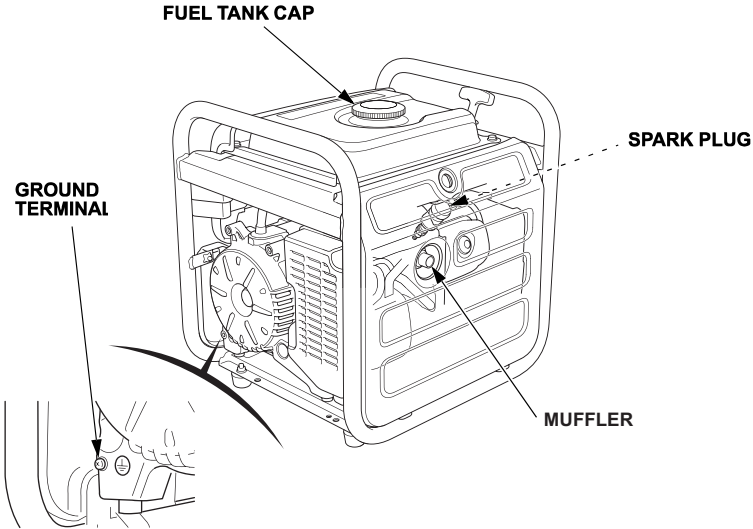
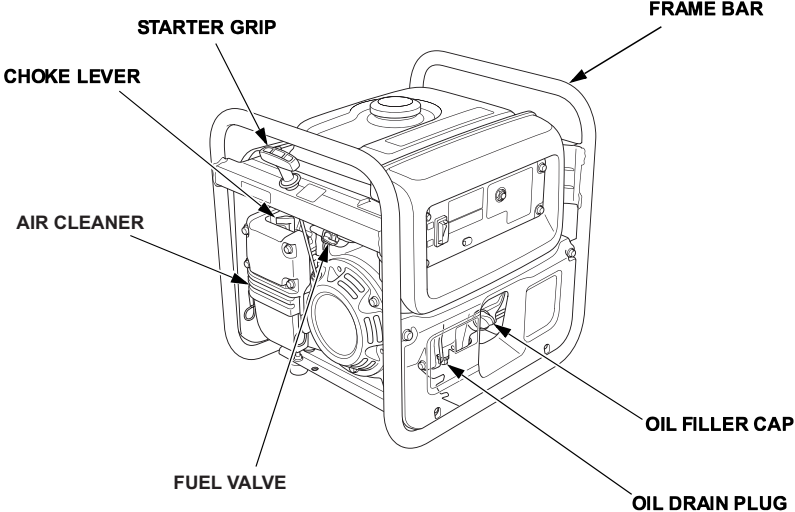

# CONTROLS & FEATURES

## CONTROLS

### Fuel Valve

The fuel valve is located between the fuel tank and carburetor.

The fuel valve must be in the ON position for the engine to run.

After stopping the engine, turn the fuel valve to the OFF position.

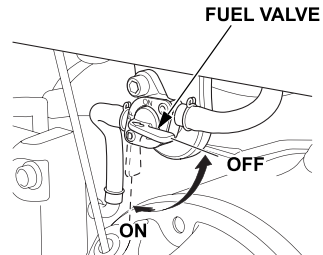

### Choke Lever

The choke lever opens and closes the choke valve in the carburetor.

The CLOSED position enriches the fuel mixture for starting a cold engine.

The OPEN position provides the correct fuel mixture for operation after starting, and for restarting a warm engine.

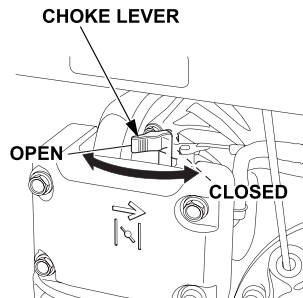

# CONTROLS & FEATURES

---

## Engine Switch

The engine switch controls the ignition system.

OFF – Stops the engine.

ON – Running position, and for starting.

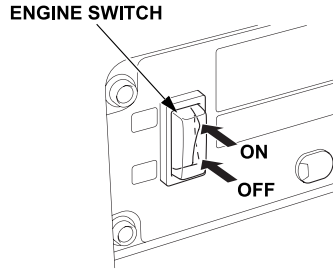

## Starter Grip

Pulling the starter grip operates the recoil starter to crank the engine for starting.

### NOTICE

- *Do not allow the starter grip to snap back against the generator. Return it gently to prevent damage to the starter.*
- *Do not let the starter rope rub against the generator body, or the rope will wear out prematurely.*

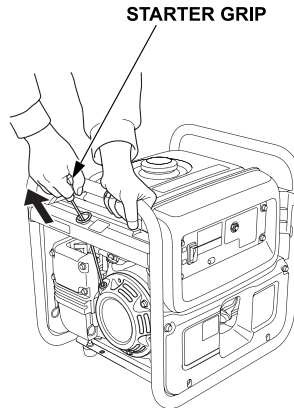

# CONTROLS & FEATURES

## AC Circuit Protector

The AC circuit protector will automatically switch OFF (push button comes out) if there is a short circuit or a significant overload of the generator at the receptacle.

If an AC circuit protector switch OFF automatically, check that the appliance is working properly and does not exceed the rated load capacity of the circuit before resetting the AC circuit protector ON (pushing the push button in).

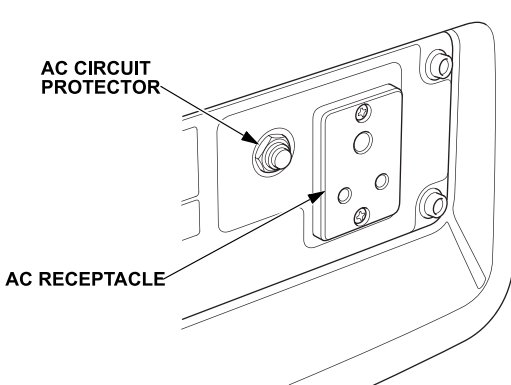

AC CIRCUIT PROTECTOR

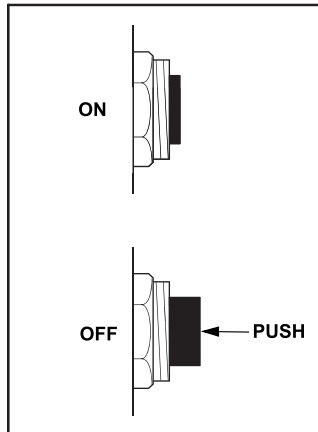

# CONTROLS & FEATURES

---

## FEATURES

### Oil Alert System

The Oil Alert system is designed to prevent engine damage caused by an insufficient amount of oil in the crankcase. Before the oil level in the crankcase can fall below a safe limit, the Oil Alert system will automatically stop the engine (the engine switch will remain in the ON position).

If the engine stops and will not restart, check the engine oil level (see page 32) before troubleshooting in other areas.

### Ground Terminal

The ground terminal is connected to the frame of the generator and the ground terminal of the receptacle.

Be sure to ground the generator when the connected appliance is grounded.

To ground the terminal of the generator, use a copper wire with same or larger diameter than the cord of the connected appliance.

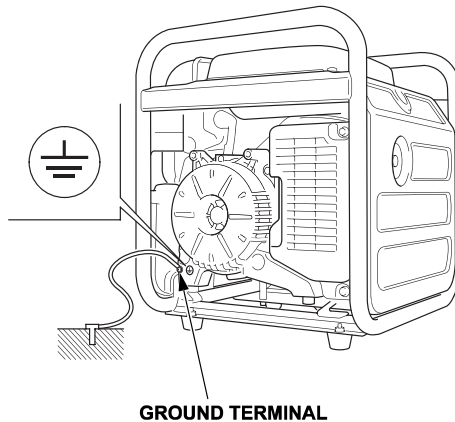

# BEFORE OPERATION

## ARE YOU READY TO GET STARTED?

Your safety is your responsibility. A little time spent in preparation will significantly reduce your risk of injury.

### Knowledge

Read and understand this manual. Know what the controls do and how to operate them.

Familiarize yourself with the generator and its operation before you begin using it. Know how to quickly shut off the generator in case of an emergency.

If the generator is being used to power appliances, be sure that they do not exceed the generator's load rating (see page 24).

## IS YOUR GENERATOR READY TO GO?

For your safety, to ensure compliance with environmental regulations, and to maximize the service life of your equipment, it is very important to take a few moments before you operate the generator to check its condition. Be sure to take care of any problem you find, or have your authorised Honda servicing dealer correct it, before you operate the generator.

### **WARNING**

Improperly maintaining this generator, or failing to correct a problem before operation, could cause a malfunction in which you could be seriously injured.

Always perform a pre-operation inspection before each operation, and correct any problem.

## BEFORE OPERATION

---

To prevent a possible fire, keep the generator at least 1 meter away from building walls and other equipment during operation. Do not place flammable objects close to the engine.

Before beginning your pre-operation checks, be sure the generator is on a level surface and the engine switch is in the OFF position.

### NOTICE

*Operating this generator less than 1 meter from a building or other obstruction can cause overheating and damage the generator. For proper cooling, allow at least 1 meter of empty space above and around the generator.*

### Check the Engine

- Before each use, look around and underneath the engine for signs of oil or petrol leaks.
- Check the oil level (see page 32). A low oil level will cause the Oil Alert system to shut down the engine.
- Check the air filter (see page 36). A dirty air filter will restrict air flow to the carburetor, reducing engine and generator performance.
- Check the fuel level (see page 30). Starting with a full tank will help to eliminate or reduce operating interruptions for refueling.

# OPERATION

## SAFE OPERATING PRECAUTIONS

Before operating the generator for the first time, review chapters *GENERATOR SAFETY* (see page 5) and *BEFORE OPERATION* (see page 17).

For your safety, do not operate the generator in an enclosed area such as a garage. Your generator's exhaust contains poisonous carbon monoxide gas that can collect rapidly in an enclosed area and cause illness or death.

<b>⚠ WARNING</b>
Exhaust contains poisonous carbon monoxide gas that can build up to dangerous levels in closed areas. Breathing carbon monoxide can cause unconsciousness or death.
Never run the generator in a closed, or even partly closed area where people may be present.

Before connecting an AC appliance or power cord to the generator:

- Use grounded 3 prong extension cords, tools, and appliances, or double insulated tools and appliances.
- Inspect cords and plugs, and replace if damaged.
- Make sure that the appliance is in good working order. Faulty appliances or power cords can create a potential for electric shock.
- Make sure the electrical rating of the tool or appliance does not exceed the rated power of the generator or the receptacle being used.
- Operate the generator at least 1 meter away from buildings and other equipment.
- Do not operate the generator in an enclosed structure.
- Do not place flammable objects close to the engine.

# OPERATION

---

## STARTING THE ENGINE

To prevent a possible fire, keep the generator at least 1 meter away from building walls and other equipment during operation. Do not place flammable objects close to the engine.

Refer to *SAFE OPERATING PRECAUTIONS* on page 19 and perform the *IS YOUR GENERATOR READY TO GO?* checks (see page 17). Refer to *AC OPERATION* (see page 23) for connecting loads to the generator.

1. Make sure that all appliances connected to the generator are turned off. The generator may be hard to start if a load is connected.

2. Turn the fuel valve to the ON position.

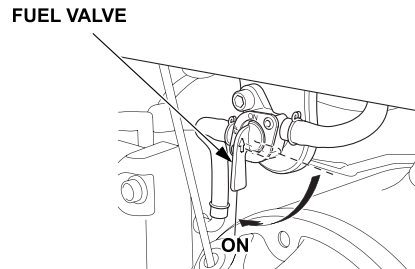

3. Move the choke lever to the CLOSED position to start a cold engine.

Leave the choke lever in the OPEN position to restart a warm engine.

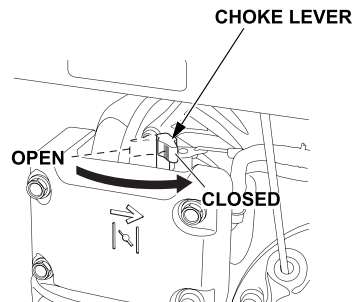

4. Turn the engine switch to the ON position.

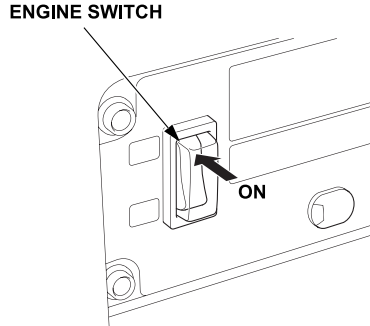

5. Pull the starter grip lightly until you feel resistance while holding the frame bars, then pull briskly in the direction of the arrow as shown.

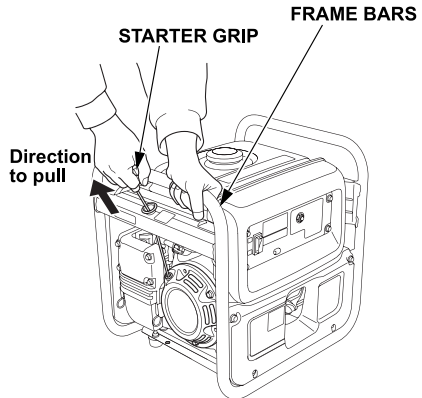

**NOTICE**

- Do not allow the starter grip to snap back against the generator. Return it gently to prevent damage to the starter.
  - Do not let the starter rope rub against the generator body, or the rope will wear out prematurely.
6. If the choke lever was moved to the CLOSED position to start the engine, gradually move it to the OPEN position as the engine warms up.

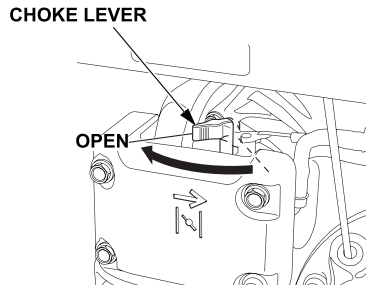

# OPERATION

---

## STOPPING THE ENGINE

To stop the engine in an emergency, simply turn the engine switch to the OFF position. Under normal conditions, use the following procedure.

1. Turn off or disconnect all appliances connected to the generator.
2. Turn the engine switch to the OFF position.

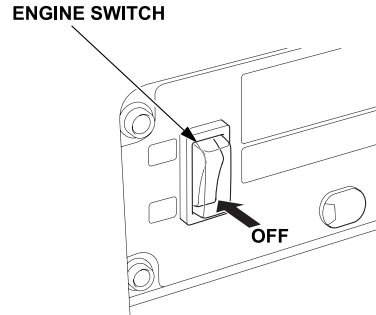

3. Turn the fuel valve to the OFF position.

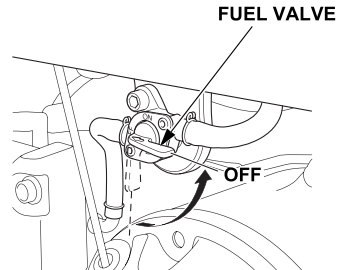

## AC OPERATION

Before connecting an appliance to the generator, make sure that it is in good working order and that its electrical rating does not exceed that of the generator.

### NOTICE

*Substantial overloading may damage the generator. Marginal overloading may shorten the service life of the generator.*

1. Start the engine (see page 20).
2. Plug an appliance into the appropriate AC receptacle.  
Most motorized appliances require more than their rated wattage for startup.

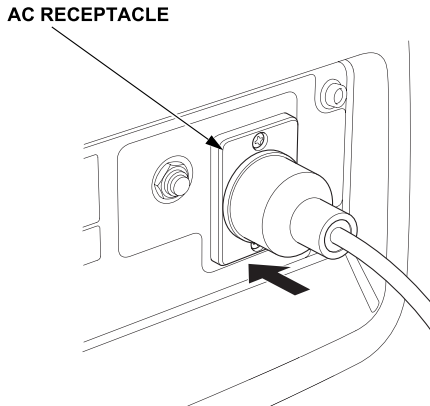

# OPERATION

---

## AC Applications

Before connecting an appliance or power cord to the generator:

- Make sure that it is in good working order. Faulty appliances or power cords can create a potential for electrical shock.
- If an appliance begins to operate abnormally, becomes sluggish, or stops suddenly, turn it off immediately. Disconnect the appliance, and determine whether the problem is the appliance or the rated load capacity of the generator has been exceeded.

Most appliance motors require more than their rated wattage for startup.

Make sure the electrical rating of the tool or appliance does not exceed the maximum power rating of the generator.

Maximum power is:

0.85 kVA

For continuous operation, do not exceed the rated power.

Rated power is:

0.75 kVA

In either case, the total power requirements (VA) of all appliances connected must be considered . Appliance and power tool manufacturers usually list rating information near the model number or serial number.

### NOTICE

*Substantial overloading will open the circuit protector. Slightly overloading the generator may not switch the circuit protector OFF, but will shorten the service life of the generator.*

## STANDBY POWER

### Connections to a Building's Electrical System

Connections for standby power to a building's electrical system must be made by a qualified electrician . The connection must isolate the generator power from utility power, and must comply with all applicable laws and electrical codes.

#### **⚠ WARNING**

Improper connections to a building's electrical system can allow current from the generator to backfeed into the utility lines.

Such backfeed may electrocute utility company workers or others who contact the lines during a power outage, and the generator may explode, burn, or cause fires when utility power is restored.

Consult the utility company or a qualified electrician prior to making any power connections.

In some areas, generators are required by law to be registered with local utility companies. Check local regulations for proper registration and use procedures.

### System Ground

This generator has a system ground that connects the generator frame components to the ground terminals in the AC output receptacles. The system ground is not connected to the AC neutral wire.

# OPERATION

---

## Special Requirements

**NOTICE**

*Do not lay the generator on its side when moving, storing, or operating it. Oil may leak and damage the engine or your property.*

There may be applicable laws, local codes, or ordinances that apply to the intended use of the generator. Please consult a qualified electrician, electrical inspector, or the local agency having jurisdiction.

- In some areas, generators are required to be registered with local utility companies.
- If the generator is used at a construction site, there may be additional regulations that must be observed.

# SERVICING YOUR GENERATOR

## THE IMPORTANCE OF MAINTENANCE

Good maintenance is essential for safe, economical, and trouble free operation. It will also help reduce air pollution.

To help you properly care for your generator, the following pages include a maintenance schedule, routine inspection procedures, and simple maintenance procedures using basic hand tools. Other service tasks that are more difficult or require special tools are best handled by professionals and are normally performed by a Honda technician or other qualified mechanic.

The maintenance schedule applies to normal operating conditions. If you operate your generator under unusual conditions, such as sustained high load or high temperature operation, or use it in dusty conditions, consult your authorised Honda servicing dealer for recommendations applicable to your individual needs and use.

### **⚠ WARNING**

Improper maintenance, or failure to correct a problem before operation, can cause a malfunction in which you can be seriously hurt or killed.

Always follow the inspection and maintenance recommendations and schedules in this owner's manual.

Remember that an authorized Honda servicing dealer knows your generator best and is fully equipped to maintain and repair it.

To ensure the best quality and reliability, use only new, Honda Genuine parts or their equivalents for repair and replacement.

# SERVICING YOUR GENERATOR

---

## MAINTENANCE SAFETY

Some of the most important safety precautions follow. However, we cannot warn you of every conceivable hazard that can arise in performing maintenance. Only you can decide whether or not you should perform a given task.

### **⚠ WARNING**

Failure to properly follow maintenance instructions and precautions can cause you to be seriously hurt or killed.

Always follow the procedures and precautions in the owner's manual.

## Safety Precautions

Make sure the engine is off before you begin any maintenance or repairs. This will eliminate several potential hazards:

- **Carbon monoxide poisoning from engine exhaust.**  
Operate outside away from open windows or doors.
- **Burns from hot parts.**  
Let the engine and exhaust system cool before touching.
- **Injury from moving parts.**  
Do not run the engine unless instructed to do so.
- Read the instructions before you begin, and make sure you have the tools and skills required.
- To reduce the possibility of fire or explosion, be careful when working around petrol. Use only a nonflammable solvent, not petrol, to clean parts. Keep cigarettes, sparks, and flames away from all fuel related parts.

# SERVICING YOUR GENERATOR

## MAINTENANCE SCHEDULE

REGULAR SERVICE PERIOD (3) Perform at every indicated month or operating hour interval, whichever comes first.		Each use	First month or 20 Hrs.	Every 3 months or 50 Hrs.	Every 6 months or 100 Hrs.	Every year or 300 Hrs.	Page
ITEM							
Engine oil	Check level	o					32
	Change		o		o		33
Air cleaner	Check	o					36
	Clean			o(1)			38
Spark plug	Check -adjust				o		39
	Replace					o	39
Valve clearance	Check -adjust					o(2)	-
A.I. air filter	Clean					o(2)	-
A.I. case drain	Drain					o(2)	-
Combustion chamber	Clean		After every 500 Hrs. (2)				-
Fuel tank and filter	Clean				o(2)		-
Fuel tube	Check		Every 2 years (Replace if necessary) (2)				-

(1) Service more frequently when used in dusty areas.

(2) These items should be serviced by your authorised servicing dealer, unless you have the proper tools and are mechanically proficient. Refer to the Honda shop manual for service procedures.

(3) For commercial use, log hours of operation to determine proper maintenance intervals.

This generator is equipped with a catalytic converter. If the engine is not properly maintained, the catalyst in the muffler may lose effectiveness.

# SERVICING YOUR GENERATOR

---

## REFUELING

With the engine stopped, remove the fuel tank cap and check the fuel level. Refill the fuel tank if the fuel level is low.

### **⚠ WARNING**

Petrol is highly flammable and explosive.

You can be burned or seriously injured when handling fuel.

- Stop the engine and keep heat, sparks, and flame away.
- Handle fuel only outdoors.
- Wipe up spills immediately.

### **NOTICE**

*Fuel can damage paint and plastic. Be careful not to spill fuel when filling your fuel tank. Damage caused by spilled fuel is not covered under warranty.*

Refuel in a well-ventilated area before starting the engine. If the engine has been running, allow it to cool. Refuel carefully to avoid spilling fuel. Do not fill the fuel tank above the upper limit mark on the fuel filter.

Never refuel the engine inside a building where petrol fumes may reach flames or sparks. Keep petrol away from appliance pilot lights, barbecues, electric appliances, power tools, etc. Spilled fuel is not only a fire hazard, it causes environmental damage. Wipe up spills immediately.

# SERVICING YOUR GENERATOR

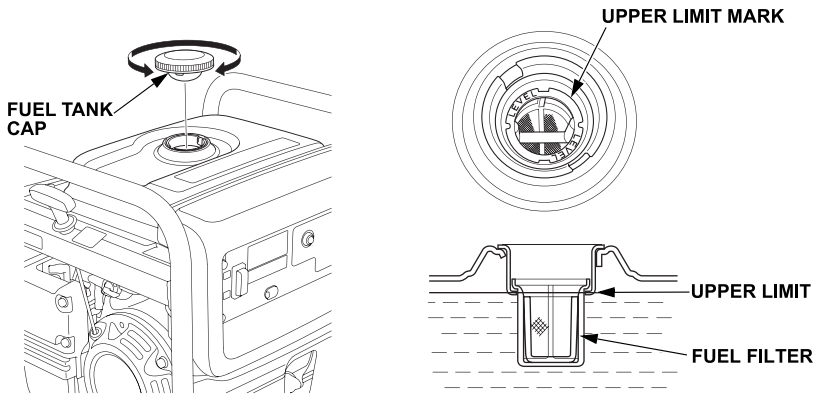

After refueling, reinstall the fuel tank cap securely.

## FUEL RECOMMENDATIONS

Use unleaded petrol with a Research Octane Number of 91 or higher.

Use unleaded petrol only, or the catalyzer will lose its effectiveness and negatively affect exhaust emissions.

Never use stale or contaminated petrol or an oil/petrol mixture. Avoid getting dirt or water in the fuel tank.

You may use regular unleaded petrol containing no more than 10% ethanol (E10) or 5% methanol by volume. In addition, methanol must contain cosolvents and corrosion inhibitors.

Use of fuels with content of ethanol or methanol greater than shown above may cause starting and/or performance problems. It may also damage metal, rubber, and plastic parts of the fuel system.

Engine damage or performance problems that result from using a fuel with percentages of ethanol or methanol greater than shown above and leaded petrol are not covered under warranty.

If your equipment will be used on an infrequent or intermittent basis, please refer to the fuel section of the *STORAGE* chapter (page 41) for additional information regarding fuel deterioration.

# SERVICING YOUR GENERATOR

---

## ENGINE OIL LEVEL CHECK

Check the engine oil level with the generator on a level surface and the engine stopped.

1. Remove the oil filler cap.

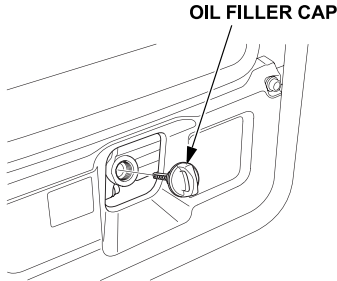

2. Check the oil level. If it is below the upper limit, fill with the recommended oil to the upper limit (see page 35).

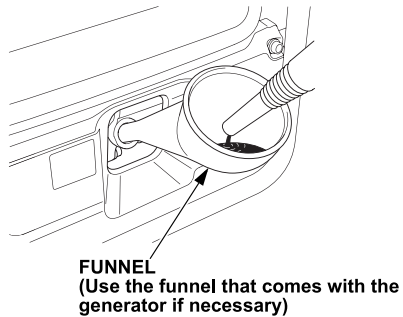
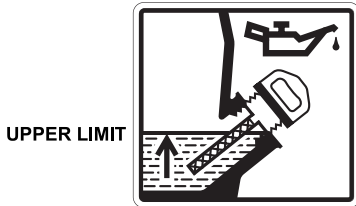

3. Reinstall the oil filler cap securely.

The Oil Alert system will automatically stop the engine before the oil level falls below safe limits. However, to avoid the inconvenience of an unexpected shutdown, check the oil level regularly.

# SERVICING YOUR GENERATOR

## ENGINE OIL CHANGE

Drain the oil while the engine is warm to assure rapid and complete draining.

1. Remove the two 6 x 18 mm bolts and washers, then remove the front cover.

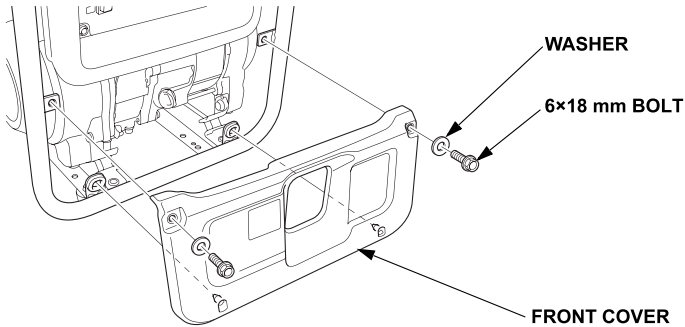

2. Place a suitable container below the engine to collect the used oil, and then remove the oil filler cap, oil drain plug, and sealing washer.

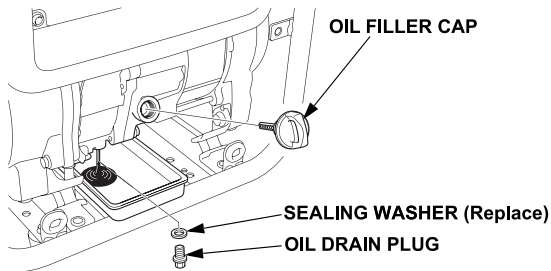

3. Allow the used oil to drain completely, and then reinstall the drain plug and a new sealing washer. Tighten the plug securely.

### NOTICE

*Improper disposal of engine oil can be harmful to the environment. If you change your own oil, please dispose of the used oil properly. Put it in a sealed container, and take it to a recycling center. Do not discard it in a trash bin, dump it on the ground, or pour it down the drain.*

# SERVICING YOUR GENERATOR

---

4. With the generator in a level surface, fill with the recommended oil to the upper limit (see page 35).

**Engine oil capacity:** 0.36 L

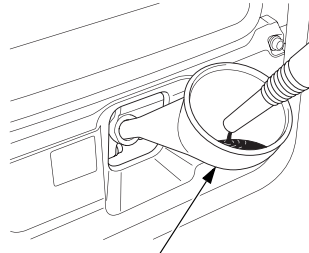
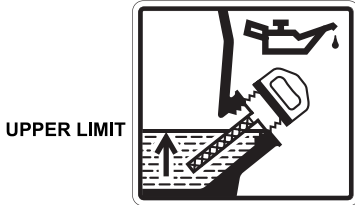

5. Reinstall the oil filler cap securely.
6. Reinstall the front cover in the reverse order of removal (see page 33).

Wash your hands with soap and water after handling used oil.

# SERVICING YOUR GENERATOR

## ENGINE OIL RECOMMENDATIONS

Oil is a major factor affecting engine performance and service life. Use PRO HONDA GENUINE 4-STROKE Engine oil.

Use 4-stroke motor oil that meets or exceeds the requirements for API service category SF or later (or equivalent). Always check the API SERVICE label on the oil container to be sure it includes the letters SF or later (or equivalent).

SAE 10W-30 is recommended for general use. Other viscosities shown in the chart may be used when the average temperature in your area is within the recommended range.

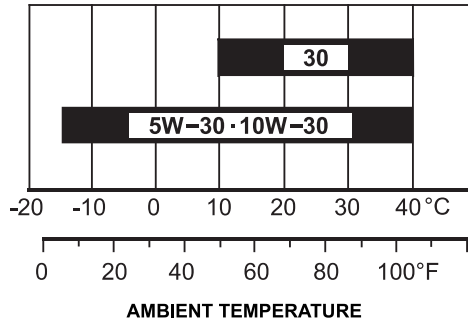

# SERVICING YOUR GENERATOR

---

## AIR CLEANER SERVICE

1. Pull the clips to unlock.
2. Remove the air cleaner case, then remove the air filter from the air cleaner case.
3. Check the air filter to be sure it is clean and in good condition.  
If the air filter is dirty, clean it as described on page 38.  
Replace the air filter if it is damaged.

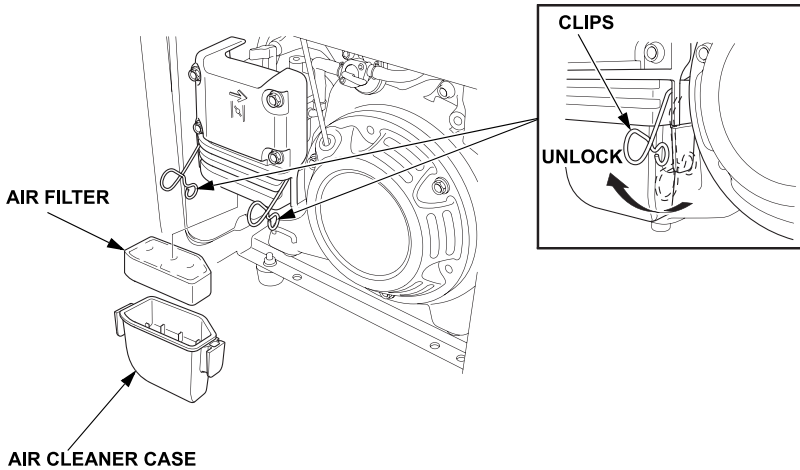

# SERVICING YOUR GENERATOR

4. Reinstall the air filter in the air cleaner case.  
Install the air filter so that it is not pinched between the air cleaner base and the air cleaner case.
5. Reinstall the air cleaner case, then push the clips to the lock position.

## NOTICE

*Operating the engine without an air filter, or with a damaged air filter, will allow dirt to enter the engine, causing rapid engine wear.*

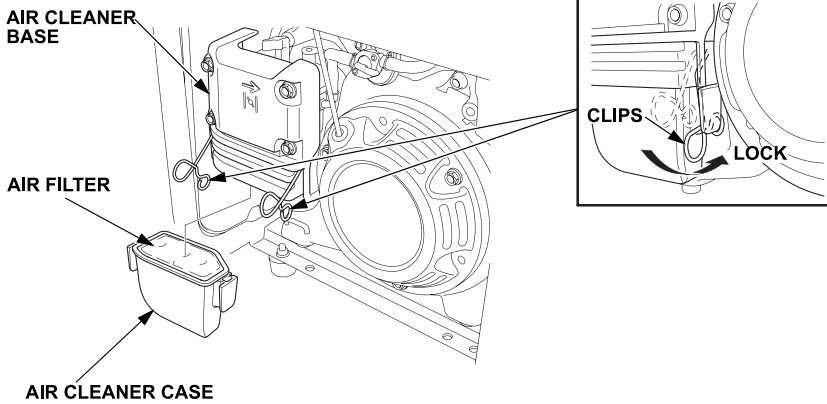

# SERVICING YOUR GENERATOR

---

## AIR FILTER CLEANING

A dirty air filter will restrict air flow to the carburetor, reducing engine performance. If you operate the generator in very dusty areas, clean the air filter more frequently than specified in the Maintenance Schedule.

1. Clean the air filter in warm soapy water, rinse, and allow to dry thoroughly, or clean in nonflammable solvent and allow to dry.
2. Dip the air filter in clean engine oil, then squeeze out all excess oil. The engine will smoke when started if too much oil is left in the air filter.

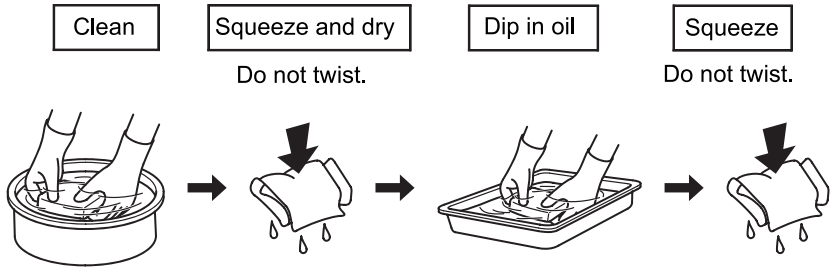

3. Wipe dirt from the air cleaner case and cover using a moist rag. Be careful to prevent dirt from entering the air duct that leads to the carburetor.

# SERVICING YOUR GENERATOR

## SPARK PLUG SERVICE

**Recommended spark plug:** LR4C-E (NGK)

**NOTICE**

*An incorrect spark plug can cause engine damage.*

1. Unlock the latch using a screwdriver or similar tool, and remove the rear cover.

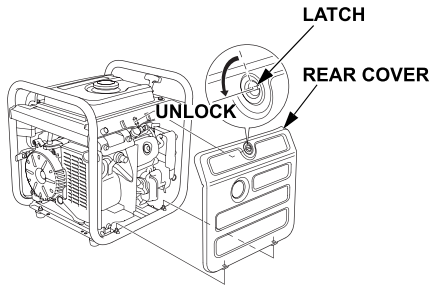

2. Disconnect the spark plug cap, and remove any dirt from around the spark plug area.
3. Remove the spark plug with a spark plug wrench.

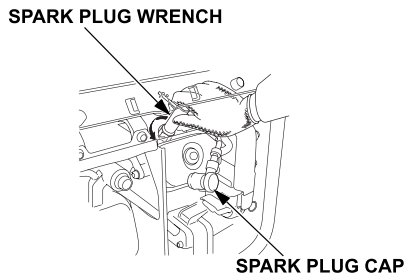

4. Inspect the spark plug. Replace it if the electrodes are worn or if the insulator is cracked, chipped, or fouled.
5. Measure the spark plug electrode gap with a wire type feeler gauge. Correct the gap, if necessary, by carefully bending the side electrode.

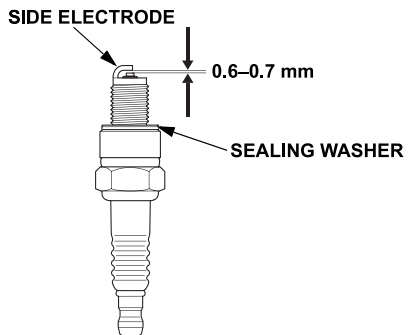

The gap should be:  
0.6–0.7 mm

# SERVICING YOUR GENERATOR

6. Make sure that the spark plug sealing washer is in good condition, and thread the spark plug in by hand to prevent cross threading.
7. After the spark plug seats, tighten with a spark plug wrench to compress the washer.

If reinstalling a used spark plug, tighten  $1/8$ – $1/4$  turn after the spark plug seats.

If installing a new spark plug, tighten  $1/2$  turn after the spark plug seats.

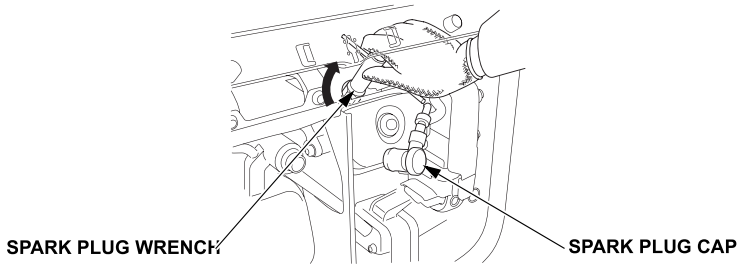

## NOTICE

*A loose spark plug can overheat and damage the engine. Overtightening the spark plug can damage the threads in the cylinder head.*

8. Attach the spark plug cap.
9. Reinstall the rear cover and turn the latch to the lock position.

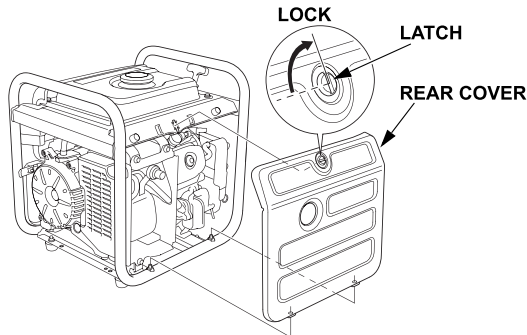

# STORAGE

## STORAGE PREPARATION

Proper storage preparation is essential for keeping your generator trouble free and looking good. The following steps will help to keep rust and corrosion from impairing your generator's function and appearance, and will make the engine easier to start when you use the generator again.

### Cleaning

Wipe the generator with a moist cloth. After the generator has dried, touch up any damaged paint, and coat other areas that may rust with a light film of oil.

### Fuel

#### NOTICE

*Depending on the region where you operate your equipment, fuel formulations may deteriorate and oxidize rapidly. Fuel deterioration and oxidation can occur in as little as 30 days and may cause damage to the carburetor and/or fuel system. Please check with your authorised Honda servicing dealer for local storage recommendations.*

Petrol will oxidize and deteriorate in storage. Old petrol will cause hard starting, and it leaves gum deposits that clog the fuel system. If the petrol in your generator deteriorates during storage, you may need to have the carburetor and other fuel system components serviced or replaced.

The length of time that petrol can be left in your fuel tank and carburetor without causing functional problems will vary with such factors as petrol blend, your storage temperatures, and whether the fuel tank is partially or completely filled. The air in a partially filled fuel tank promotes fuel deterioration. Very warm storage temperatures accelerate fuel deterioration. Fuel deterioration problems may occur after 30 days from keeping the fuel in the fuel tank, or even less depending on the petrol formulation in your area.

# STORAGE

---

## STORAGE PROCEDURE

1. Drain the fuel tank and carburetor.

<b>⚠ WARNING</b>
<p>Petrol is highly flammable and explosive.</p> <p>You can be burned or seriously injured when handling fuel.</p> <ul style="list-style-type: none"><li>• Stop the engine and keep heat, sparks, and flame away.</li><li>• Handle fuel only outdoors.</li><li>• Wipe up spills immediately.</li></ul>

- a. Unscrew the fuel tank cap and remove the fuel filter.
- b. Drain all petrol from the fuel tank into an approved petrol container. We recommend using a commercially available petrol hand pump. Do not use an electric pump.

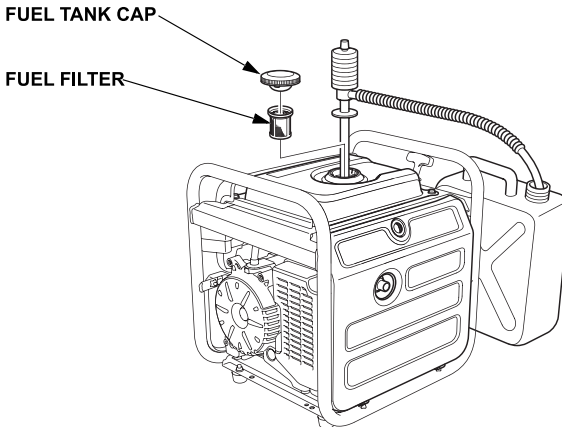

- c. Remove the rear cover (see page 39).

- d. Turn the fuel valve to the ON position (see page 20).
- e. Loosen the carburetor drain screw and drain the petrol from the carburetor into a suitable container.

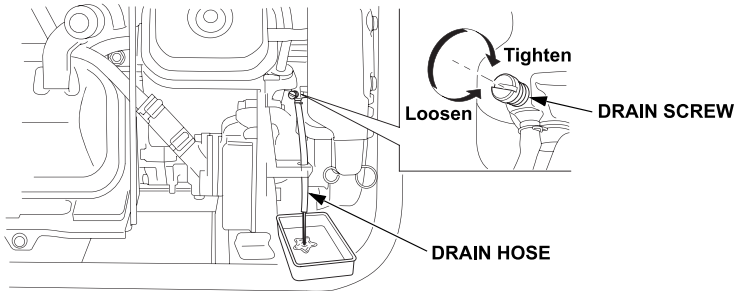

- f. After all fuel has drained into a suitable container, tighten the drain screw.
2. Change the engine oil (see page 33).
  3. Remove the spark plug (see page 39).
  4. Pour a teaspoon (5 cm<sup>3</sup>) of clean engine oil into the cylinder.
  5. Pull the starter rope several times to distribute the oil in the cylinder.
  6. Reinstall the spark plug (see page 40).
  7. Reinstall the rear cover (see page 40).
  8. Slowly pull the starter grip until resistance is felt. At this point, the piston is coming up on its compression stroke and both the intake and exhaust valves are closed. Storing the engine in this position will help to protect it from internal corrosion. Return the starter grip gently.

# STORAGE

---

## STORAGE PRECAUTIONS

If your generator will be stored with petrol in the fuel tank and carburetor, it is important to reduce the hazard of petrol vapor ignition.

Select a well-ventilated storage area away from any appliance that operates with a flame, such as a furnace, water heater, or clothes dryer. Also avoid any area with a spark-producing electric motor, or where power tools are operated.

If possible, avoid storage areas with high humidity, because that promotes rust and corrosion.

Unless all fuel has been drained from the fuel tank, leave the fuel valve in the OFF position to reduce the possibility of leakage.

Place the generator on a level surface. Tilting can cause fuel or oil leakage.

With the engine and exhaust system cool, cover the generator to keep out dust. A hot engine and exhaust system can ignite or melt some materials.

Do not use sheet plastic as a dust cover. A nonporous cover will trap moisture around the generator, promoting rust and corrosion.

## REMOVAL FROM STORAGE

Check your generator as described in the *BEFORE OPERATION* chapter of this manual (see page 17).

If the fuel was drained during storage preparation, fill the tank with Fresh petrol. If you keep a container of petrol for refueling, be sure that it contains only fresh petrol. Petrol oxidizes and deteriorates over time, causing hard starting.

If the cylinder was coated with oil during storage preparation, the engine may smoke briefly at startup. This is normal.

# TRANSPORTING

## BEFORE TRANSPORTING

1. Make sure the engine switch, fuel valve are OFF (see page 22).
2. Drain all petrol from the fuel tank, tighten the fuel tank cap securely (see page 42).

<b>⚠ WARNING</b>
<p>Petrol is highly flammable and explosive.</p> <p>You can be burned or seriously injured when handling fuel.</p> <ul style="list-style-type: none"><li>• Stop the engine and keep heat, sparks, and flame away.</li><li>• Handle fuel only outdoors.</li><li>• Wipe up spills immediately.</li></ul>

## WHEN TRANSPORTING THE GENERATOR

If the generator has been running, allow the engine to cool down before loading the generator on the vehicle.

A hot engine and exhaust system can burn you and can ignite some materials.

Do not load the generator on a vehicle to transport with the fuel filled. The fuel may leak due to vibration during transport.

When transporting the generator, turn the engine switch and the fuel valve lever OFF, and Keep the generator level to reduce the possibility of fuel leakage.

Avoid a place exposed to direct sunlight when putting the generator on a vehicle. If the generator is left in an enclosed vehicle for many hours, high temperature inside the vehicle could cause fuel to vaporize resulting in a possible explosion.

Do not drive on a rough road for an extended period with the generator on board.

# TRANSPORTING

---

## Transporting the Generator by Truck

Load the generator on a place where it will not drop off, tumble over or be damaged and tie it up with ropes or tie down straps.

When using ropes or tie down straps to secure the generator for transportation, only use the frame bars as attachment points, by protecting them with protective cloths or equivalent. Do not fasten ropes or straps to any other portions of the generator body.

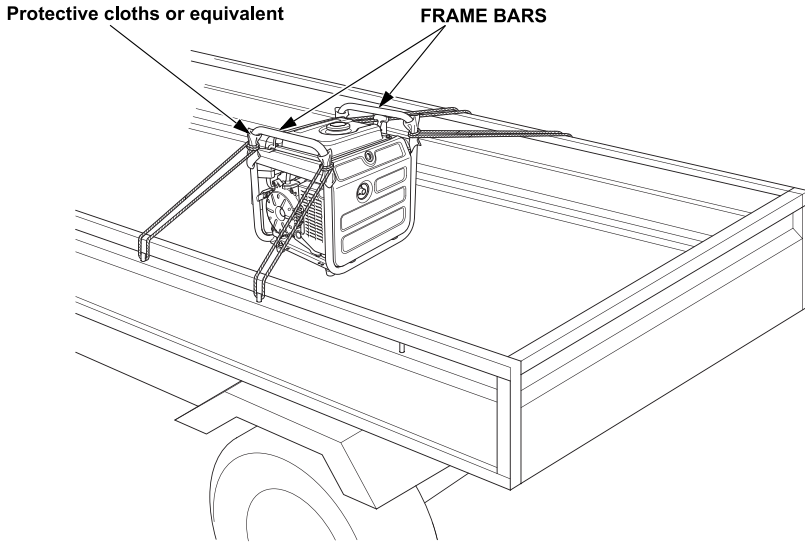

## Transporting the Generator by Hand

When you or with your assistant are to lift up your generator by hands, make sure to lift by the frame bars.

If there is "lifting weight limit" law or regulation in your country, please obey.

[Lifting by 2 people]

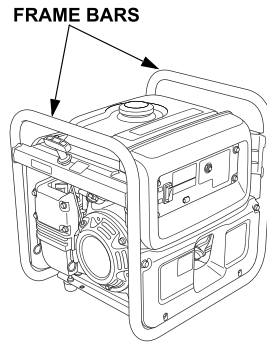
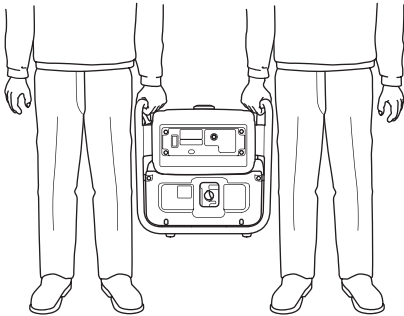

[Lifting by 1 person]

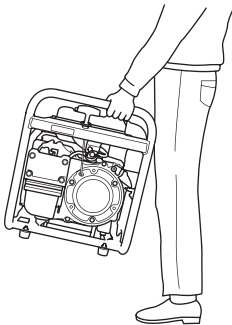

# TAKING CARE OF UNEXPECTED PROBLEMS

## ENGINE WILL NOT START

Possible Cause	Correction
Fuel valve OFF.	Turn valve ON (see page 13).
Choke OPEN.	Move to CLOSED unless engine is warm (see page 13).
Engine switch OFF.	Turn engine switch to ON (see page 14).
Out of fuel.	Refuel (see page 30).
Bad fuel; generator stored without treating or draining petrol, or refueled with bad petrol.	Drain fuel tank and carburetor (see page 42). Refuel with fresh Petrol (see page 30).
Low oil level caused Oil Alert to stop engine.	Add oil (see page 32). Restart the engine.
Spark plug faulty, fouled, or improperly gapped.	Gap, or replace spark plug (see page 39).
Spark plug wet with fuel (flooded engine).	Dry and reinstall spark plug.
Fuel filter restricted, carburetor malfunction, ignition malfunction, valves stuck, etc.	Take generator to your authorised Honda servicing dealer, or refer to shop manual.

## Engine Lacks Power

Possible cause	Correction
Air filter restricted.	Clean or replace air filter (see page 36 through 38).
Bad fuel; generator stored without treating or draining petrol, or refueled with bad petrol.	Drain fuel tank and carburetor (see page 42). Refuel with fresh Petrol (see page 30).
Fuel filter restricted, carburetor malfunction, ignition malfunction, valves stuck, etc.	Take generator to your authorised Honda servicing dealer, or refer to shop manual.

## **TAKING CARE OF UNEXPECTED PROBLEMS**

---

### **NO POWER AT THE AC RECEPTACLE**

<b>Possible Cause</b>	<b>Correction</b>
AC circuit protector tripped.	Check AC load and reset circuit protector (see page 15).
Faulty power tool or appliance.	Replace or repair power tool or appliance. Stop and restart the engine.
Faulty generator.	Take generator to your authorised Honda servicing dealer, or refer to shop manual.

# TECHNICAL INFORMATION

## SERIAL NUMBER LOCATIONS

FRAME SERIAL NUMBER

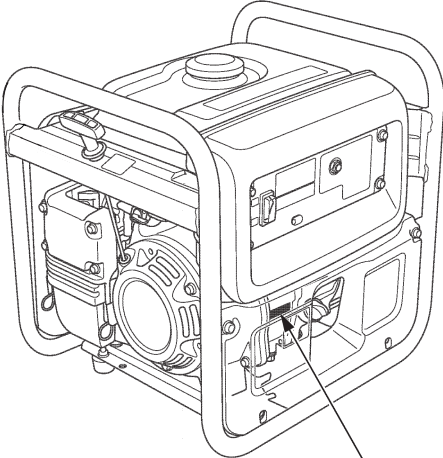
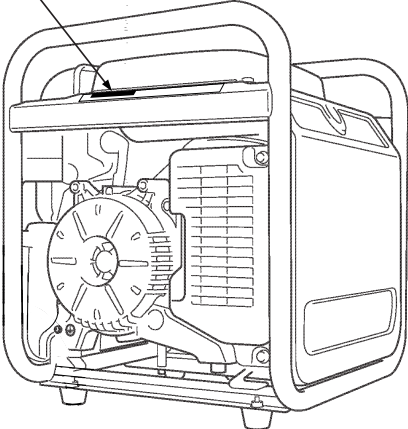

ENGINE SERIAL NUMBER

# TECHNICAL INFORMATION

---

## CARBURETOR MODIFICATION FOR HIGH ALTITUDE OPERATION

At high altitude, the standard carburetor air fuel mixture will be too rich. Performance will decrease, and fuel consumption will increase. A very rich mixture will also foul the spark plug and cause hard starting. Operation at an altitude that differs from that at which this engine was certified, for extended periods of time, may increase emissions.

High altitude performance can be improved by specific modifications to the carburetor. If you always operate your generator at altitudes above 610 meters, have your authorized Honda servicing dealer perform this carburetor modification.

Even with carburetor modification, engine horsepower will decrease about 3.5% for each 300 meter increase in altitude. The effect of altitude on horsepower will be greater than this if no carburetor modification is made.

### NOTICE

*When the carburetor has been modified for high altitude operation, the air/fuel mixture will be too lean for low altitude use. Operation at altitudes below 610 meters with a modified carburetor may cause the engine to overheat and result in serious engine damage. For use at low altitudes, have your authorised Honda servicing dealer return the carburetor to original factory specifications.*

# TECHNICAL INFORMATION

---

## SPECIFICATIONS

### Dimensions

Model	EP1000
Description code	EEHD
Length	404 mm
Width	352 mm
Height	431 mm
Dry mass (weight)	27.8 kg

### Engine

Model	GX80D
Engine Type	4-stroke, overhead valve, single cylinder
Displacement	79.7 cm <sup>3</sup>
Bore×Stroke	46.0×48.0 mm
Cooling System	Forced air
Ignition System	Transistorized magneto ignition
Oil Capacity	0.36 L
Fuel Tank Capacity	3.6 L
Spark Plug	LR4C-E (NGK)

### Generator

Model	EP 1000	
Type	RD	
AC output	Rated voltage	230 V
	Rated frequency	50 Hz
	Rated ampere	3.3 A
	Rated output	0.75 kVA
	Max output	0.85 kVA

Specifications are subject to change without notice.

# WARRANTY POLICY

## 1. INTRODUCTION

- Warranty is an assurance to the customer of a quality product. Honda warrants all its GENERATOR models to be free from any manufacturing defect. In the event of failure, any Honda authorised dealer will repair or replace, free of charge, any part of the set as per norms laid down by the company. The company's decision shall be final and binding.

## 2. WARRANTY PERIOD

### GENERATOR

- Two years from the date of purchase for Non-Commercial use by customer.
- Two years from the date of purchase for Commercial/Rental use by customer.

## 3. WARRANTY OBLIGATION

- Repair or replacement of defective part(s), at any authorised dealer, free of charge, if found defective by reasons of defective material or poor workmanship.

## 4. WARRANTY SERVICE

- To obtain warranty service the complete set must be presented to any of authorised dealer service point at customer's risk and expense.

## 5. TERMS AND CONDITIONS

- a. To qualify for warranty, Honda generator must be set-up and serviced by an authorised Honda dealer.
- b. Presentation of this warranty & free service coupon booklet.
- c. Warranty does not include :
  1. Normal/natural wear & tear and normal deterioration of paint or other appearances.
  2. Failures resulting from unauthorised modifications or repairs.
  3. Failures resulting due to not availing of free service within the stipulated time.
  4. Rubber parts, Hardware items like Nuts & Bolts, Element Air Cleaner, Filters, Electrical Wires, Spark Plug, Gaskets, Starter Rope, Oil and petrol.
  5. Damages or failures resulting from misuse, operational faults, negligence, abnormal use, insufficient care, over-loading, accident or fire from external source, theft, chemical fall out, stone chipping, industrial pollution, transportation.
  6. Failures due to usage of non recommended or adulterated engine oil and fuel. Failures due to usage of mixture of engine oil and fuel.
  7. Normal phenomena such as noise and vibrations.
  8. Incidental or consequential damages like inconvenience or commercial loss.
  9. Any part or labour incurred in normal maintenance services.
  10. Failures resulting from usage of non genuine spare part(s).

Note : All disputes are subject to jurisdiction of Delhi court only.

# INSTALLATION AND FREE SERVICES

## 1. PRE-INSTALLATION CHECK (P.I.C.)

- A pre delivery inspection is provided by Honda dealer so that you can enjoy longer trouble free Generator life.
- P.I.C. coupon is attached herewith.

**Note:**

To avoid transshipment damage, Bracket packing is installed with fasteners to arrest the movement of engine with alternator. These should be removed from Generator set by the selling dealer prior to sale.

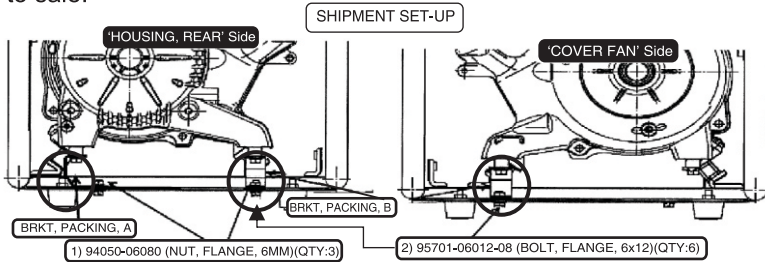

## 2. PERIODIC MAINTENANCE SERVICE

- To enhance trouble free Generator life, periodic maintenance must be carried out as per maintenance schedule given in the owner's manual.

## 3. FREE SERVICE

- Three free service coupons are attached.
- Customer is requested to bring the Generator to any authorised dealer/ service point alongwith this booklet for availing free service.
- Free service can be availed at any of the authorised dealer / service point.
- This offer is valid only for the free services as per the schedule given in the chart below.

Type of Service	Schedule (From date of P.I.C)		Other Details
	Days	Cum. operational hours	
Service I	30	20	Labour Free but consumables chargeable to the customer
Service II	90	50	
Service III	180	100	

# Honda India Power Products Limited

Head Office: Plot No. 5, Sector-41, Kasna, Greater Noida Industrial Development Area,  
Distt. Gautam Budh Nagar - 201310, Uttar Pradesh.

Tel.: 0120-2590100

## LIST OF AREA OFFICES

### AHMEDABAD

A-904, Siddhi Vinayak Tower,  
B/H DCP Office, Off S.G. Highway, Makarba,  
Ahmedabad - 380051, Gujarat.  
Tel. : 079-48000730,9978912986  
E-mail: ao.ahm@hipp.co.in

### BENGALURU

'Solus' D-07, 7<sup>th</sup> Floor, 1<sup>st</sup> Cross, J.C. Road,  
Opposite Bengaluru Stock Exchange,  
Bengaluru - 560027, Karnataka  
Tel. : 080-22217152  
E-mail: ao.blr@hipp.co.in

### BHOPAL

10, Sarnath Complex, 2nd Floor,  
Opp. M.P Board Office,  
Link Road No. 1, Shivaji Nagar,  
Bhopal - 462016, Madhya Pradesh.  
Tel. : 0755-4258515  
E-mail: ao.bho@hipp.co.in

### BHUBANESWAR

Plot No. 62 & 63, Ganganagar, Unit-6,  
Bhubaneswar - 751001, Odisha.  
Tel. : 0674-2397352, 2397477  
E-mail: ao.bhu@hipp.co.in

### CHANDIGARH

Metro Plaza City Market, 1st Floor,  
SCO-27, Lohgarh Road, Zirakpur,  
Dist. SAS Nagar - 140603, Punjab  
Tel. : 01762-531109  
E-mail: ao.chd@hipp.co.in

### CHENNAI

1st Floor of Old No.79, New No.13,  
Coundamani Flats, Bhaskar Colony,  
Virugambakkam,  
Chennai - 600092, Tamil Nadu  
Tel. : 044-23767091, 23767092  
E-mail: ao.mad@hipp.co.in

### COCHIN

Door No. 44/2214 D3, 2nd Floor,  
Holy Tuesday Shopping Mall, Kaloor,  
Kochi - 682017, Kerala.  
Tel. : 0484-2537753, 2537763  
E-mail: ao.coch@hipp.co.in

### RANCHI

Raghav Kunj, Lake Road,  
Opposite Goyal sanitary,  
Near Kishoreganj Chowk,  
Ranchi - 834001, Jharkhand.  
Tel. : 0651-2214230  
E-mail: ao.ranchi@hipp.co.in

### GUWAHATI

Space no.- 306-307, 3rd.Floor,  
Silver Oak Plaza, Near Sarusajai  
Stadium, Lokhra, NH-37,  
Guwahati - 781034, Assam.  
Tel. : 1800-11-2323  
E-mail: ao.guw@hipp.co.in

### HYDERABAD

Plot No.48, 2nd Floor,  
Above Indian Overseas Bank,  
West Marredpally,  
Secunderabad - 500026, Telangana.  
Tel. : 040-27803449, 27803450  
E-mail: ao.hyd@hipp.co.in

### JAMMU

Plot No. 50, Yard No.6, Near SRTC Yard,  
Transport Nagar, Narwal,  
Jammu - 180006, J&K(UT)  
Tel. : 0191-2490058  
E-mail: ao.jmu@hipp.co.in

### KOLKATA

15th Floor, Unit No 1503,  
Ergo Tower, Salt Lake, Sector - 5,  
Kolkata - 700091, West Bengal.  
Tel. : 033-48080030  
E-mail: ao.cal@hipp.co.in

### LUCKNOW

80, Chandralok Colony, Aliganj,  
Lucknow - 226204, Uttar Pradesh  
Tel. : 0522-4720076  
E-mail: ao.luk@hipp.co.in

### MUMBAI

A-212, 2nd Floor, Sagar Tech Plaza,  
Sakinaka, Andheri (E),  
Mumbai - 400072, Maharashtra.  
Tel. : 022-28511342, 28513874, 46043223  
E-mail: ao.mum@hipp.co.in

### DELHI

Plot No. 5, Sector - 41, Kasna,  
Greater Noida Industrial Development Area,  
Gautam Budh Nagar - 201310, Uttar Pradesh.  
Tel. : 0120-2590244  
E-mail: ao.del@hipp.co.in

**Pro Honda**  
Genuine Lubes & Chemicals

Fully Synthetic Engine Oil

4 STROKE

Honda developed PRO HONDA to maximize performance of every Honda engine.

Enhances Performance

Ensures Longer Engine Life

Meeting International Quality Standards

Available in  
20 L  
1.2 L  
600 ml  
350 ml

Best fit for your Power Products and Outboard motors

GENERATOR WATER PUMP LAWN MOWER BRUSH CUTTER TILLER ENGINE OUTBOARD MOTOR

## Disposal

To protect the environment, do not dispose off the used generator, engine oil, etc. carelessly by leaving them in the waste. Observe the local laws or regulations or consult your authorized Honda generator dealer to dispose off these parts.

Please dispose off used engine oil in a manner that is compatible with the environment. We suggest you take it in a sealed container to your local service station for reclamation. Do not throw it in the trash or pour it on the ground.

## निपटान

पर्यावरण की सुरक्षा के लिए प्रयुक्त जेनरेटर, इंजन ऑयल आदि को लापरवाही से अपशिष्ट में छोड़कर उनका निपटान न करें। इनका निपटान करने के लिए स्थानीय कानूनों व नियमों का निरीक्षण करें या अपने अधिकृत होण्डा जेनरेटर डीलर से परामर्श करें।

कृपया इस्तेमाल किए गए इंजन ऑयल को ऐसे तरीके से निपटान करें जो पर्यावरण के अनुकूल हो। हम आपको सुझाव देते हैं कि आप इसे सील बंद कंटेनर में संशोधन के लिए अपने स्थानिय सर्विस स्टेशन पर ले जाए। इसे कचरे में न फेंके और न ही जमीन पर बहायें।

# HONDA



## Honda India Power Products Limited

Regd. Off. : 409, DLF Tower B,  
Jasola Commercial Complex,  
New Delhi -110 025.

E-mail : [ho.mktg@hipp.co.in](mailto:ho.mktg@hipp.co.in)

Website : [www.hondaindiapower.com](http://www.hondaindiapower.com)

To access information about  
Operations, Maintenance &  
Troubleshooting, please visit:  
[www.hppsv.com/IND/](http://www.hppsv.com/IND/) or scan



4MZ36812  
00X4M-Z36-8123

© Honda India Power Products Ltd. 2026

(MP) XXX.XXXXXX

Printed in XXXXX