

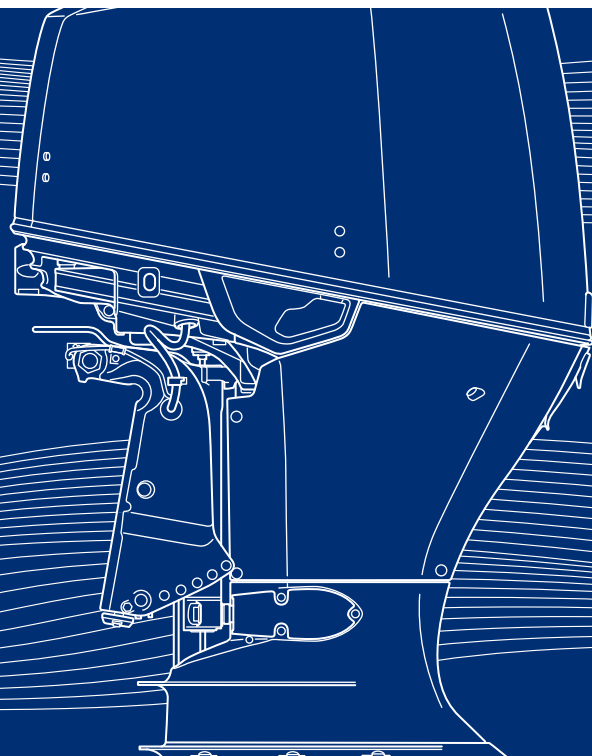

Owner's Manual
BF115J • BF135D •
BF150D



Original instructions

Thank you for purchasing a Honda Outboard Motor.

This manual covers operation and maintenance of the Honda BF115J/135D/150D Outboard Motor. All information in this publication is based on the latest product information available at the time of approval for printing. Honda Motor Co., Ltd. reserves the right to make changes at any time without notice and without incurring any obligation.

No part of this publication may be reproduced without written permission.

This manual should be considered a permanent part of the Outboard Motor and should remain with it if it is resold.

For information regarding the optional equipment, refer to the owner's manual that came with it.

Throughout this manual, you will see safety messages preceded by the following words and symbols. Here's what they mean:

DANGER

Indicates serious injury or death **WILL** result if instructions are not followed.

WARNING

Indicates a strong possibility that serious personal injury or death may result if instructions are not followed.

CAUTION

Indicates a possibility that personal injury or equipment damage could result if instructions are not followed.

NOTICE

Indicates that equipment or property damage could result if instructions are not followed.

NOTE: Gives helpful information.

If a problem should arise, or if you have any questions about the Outboard Motor, consult an authorized Honda Outboard Motor dealer.

WARNING

Honda Outboard Motors are designed to give safe and dependable service if operated according to instructions. Read and understand the Owner's Manual before operating the Outboard Motor. Failure to do so could result in personal injury or equipment damage.

Honda Motor Co., Ltd. 2021, All Rights Reserved

Control and Feature Identification Codes

Model		BF115J						BF135D						BF150D									
Type		LR□	LD□	XR□	XD□	XCR□	XCD□	LR□	LD□	XR□	XD□	XCR□	XCD□	LCR□	LCD□	LR□	LD□	XR□	XD□	XCR□	XCD□	LCR□	LCD□
Transom Height	508 mm (20.0 in)	•	•					•	•					•	•	•	•					•	•
	635 mm (25.0 in)			•	•	•	•			•	•	•	•					•	•	•	•		
Standard Rotating Propeller Shaft		•	•	•	•			•	•	•	•					•	•	•	•				
Counter-rotating Propeller Shaft						•	•					•	•	•	•					•	•	•	•
Mechanical wire		•		•		•		•		•		•		•		•		•		•		•	
Drive by Wire (DBW)			•		•		•		•		•		•		•		•		•		•		•

NOTE: Note that the types of the outboard motor differ according to the countries where they are sold.

BF115J/135D/150D is provided with the following types according to the shaft length and the rotating direction of the propeller shaft.

TYPE CODE

Example

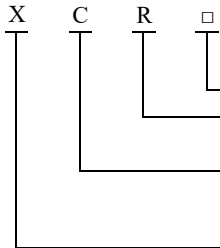

- Destination
- R: Remote Control
- R: Mechanical wire D: Drive by Wire (DBW)
- C: Rotating direction of propeller shaft
- C: Counter-rotating propeller shaft is equipped.
- None: Standard rotating propeller shaft is equipped.
- X: Transom Height
- L: 508 mm (20.0 in), X: 635 mm (25.0 in)

How To Determine Which Direction The Propeller Shaft Rotates

The direction the propeller shaft rotates can be determined based on whether or not the shaft has a groove.
With groove: Counter-rotating
Without groove: Standard rotating

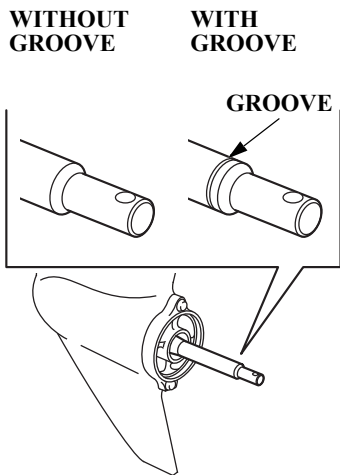

Remote Control Types

The remote control type is classified into the following three categories according to the control box position.

Flush-mount type

(DBW type): D1 type

Top-mount type

(DBW type): D2 type

Side-mount type: R1 type

Flush-mount type

(Mechanical wire type): R2 type

Top-mount type

(Mechanical wire type): R3 type

Check the type of your outboard motor and read this Owner's Manual thoroughly before operation. Texts with no type indication are the information and/or procedures common to all types.

Serial Number Locations

FRAME SERIAL NUMBER

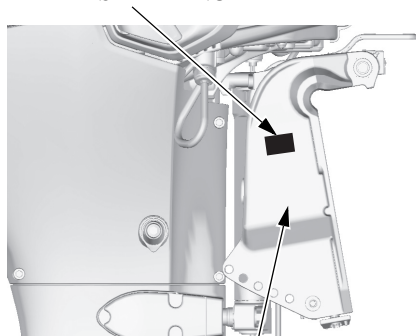

RIGHT STERN BRACKET

Record the frame and engine serial numbers for your reference. Refer to the serial numbers when ordering parts, and when making technical or warranty inquiries.

The frame serial number is stamped on a plate attached on the right side of the stern bracket.

Frame serial number:

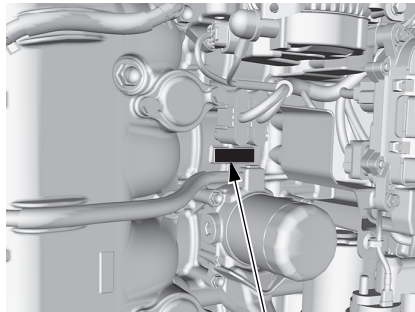

ENGINE SERIAL NUMBER

The engine serial number is stamped on the upper right side of the engine.

Engine serial number:

CONTENTS

1. SAFETY	8	Emergency Stop Switch Lanyard/ Clip	42
SAFETY INFORMATION	8	Spare Emergency Stop Switch Clip (optional equipment)	43
2. SAFETY LABEL LOCATIONS	10	Tilt Lock Lever	44
CE mark/UKCA mark location [European types]	11	Trim Tab	44
3. COMPONENT IDENTIFICATION	12	Anodes	44
4. CONTROLS AND FEATURES	22	Cooling Water Check Hole	45
Remote Control Lever (D1 type)	22	Cooling Water Intake Port	45
Remote Control Lever (D2 type)	23	Engine Cover Latches	45
Remote Control Lever (R1 type)	24	Tachometer (optional equipment)	46
Remote Control Lever (R2 type)	25	NMEA Interface Coupler	46
Remote Control Lever (R3 type)	26	Operating Hour Notification System	46
Neutral Release Lever	27	How to reset the Hour Counter	48
Ignition Switch	28	Battery Switch OFF Notification	48
Power Switch (Normal Key type)	29	5. INSTALLATION	49
Power Switch (Honda Smart Key type)	29	Transom Height	49
Honda Smart Key (optional equipment)	29	Location	50
START/STOP SWITCH	30	Installation Height	50
FUNCTION SWITCHES (D1 type)	31	Outboard Motor Installation	51
FUNCTION SWITCHES (D2 type)	32	Outboard Motor Angle Inspection (Cruising)	52
Fast Idle Lever (R1 type)/Fast Idle Button (R2, R3 types)	34	Battery Connections	53
PGM-FI Indicator/Buzzer	35	Remote Control Installation (optional equipment)	55
ACG Indicator/Buzzer	36	<Remote Control Box Location>	58
Oil Pressure Indicator/Buzzer	36	<Remote Control Cable Length>	58
Overheat Indicator/Buzzer	37	Propeller Selection	59
Water Separator Buzzer	37	Fuel Line Connection	59
Power Trim/Tilt Switch	38	6. PRE-OPERATION CHECKS	60
PTT SWITCH PANEL	39	Engine Cover Removal/Installation	60
Trim Meter (optional equipment)	40	Engine Oil	61
Power Tilt Switch (outboard motor pan)	40	Fuel	63
TRL (Trolling) Control Switch	41	GASOLINE CONTAINING ALCOHOL	64
Manual Relief Valve	41	Propeller and Cotter Pin Inspection	65
Emergency Stop Switch	42	Remote Control Lever Friction	66

CONTENTS

Fuel Filter with Water Separator	67	<Over-rev Limiter>	110
Battery	68	<Anodes>	110
Other Checks	69	<Power Reduction>	110
7. STARTING THE ENGINE	70	Shallow Water Operation	111
Fuel Priming	70	Multiple Outboard Motors	111
Starting the Engine	70	9. STOPPING THE ENGINE	112
(D1, D2 types)	70	Emergency Engine Stop	112
(R1 type)	75	Normal Engine Stop (D1, D2 types)	112
(R2, R3 types)	78	Normal Engine Stop (D1, D2 without START/STOP Switch type) (R1, R2, R3 types)	114
Station Select Mode	82	10. TRANSPORTING	116
8. OPERATION	83	Fuel Line Disconnection	116
Break-in Procedure	83	Transporting	116
Gear Shifting (D1 type)	84	Trailerage	117
Gear Shifting (D2 type)	85	11. CLEANING AND FLUSHING	118
Gear Shifting	86	12. MAINTENANCE	119
(R1 type)	86	Tool Kit and Owner's Manual	120
(R2 type)	87	<Spare Emergency Stop Switch Clip (optional equipment)>	120
(R3 type)	88	MAINTENANCE SCHEDULE	121
Cruising	89	Engine Oil	123
TRL (Trolling) Control Switch (Mechanical wire type)	92	Engine Oil Replacement	123
Trolling Mode (DBW type)	93	Spark Plugs	124
One-Lever Mode	94	Lubrication	129
Trimming the Outboard Motor	95	Fuel Filter with Water Separator	131
Trim Meter (optional equipment)	98	EMISSION CONTROL SYSTEM	134
Tilting the Outboard Motor	99	Battery	135
Moorage	101	Fuse	137
Power Tilt Switch (outboard motor pan)	102	Main Fuse	138
Manual Relief Valve	103	3 A Fuse	139
Trim Tab Adjustment	104	ACG Fuse	139
Engine Protection System	105		
<Engine Oil Pressure, Overheat, Water Contamination, PGM-FI and ACG Warning Systems>	105		

CONTENTS

Power Harness	139
Propeller	140
Inspect After Operating	141
Submerged Outboard Motor	141
13. STORAGE	143
Fuel	143
Vapor Separator Draining	143
Engine Oil	144
Battery Storage	145
Outboard Motor Position	146
14. DISPOSAL	147
15. TROUBLESHOOTING	148
Emergency Gear Shifting (for DBW type)	150
16. SPECIFICATIONS	151
17. MAJOR Honda DISTRIBUTOR ADDRESSES	155
18. “UK DECLARATION OF CONFORMITY” CONTENT	
OUTLINE	158
19. “EC DECLARATION OF CONFORMITY” CONTENT	
OUTLINE	159
20. INDEX	164

1. SAFETY

SAFETY INFORMATION

For your safety and the safety of others, pay special attention to these precautions.

Operator Responsibility



- **Honda outboard motor is designed to give safe and dependable service if operated according to instructions. Read and understand the Owner's Manual before operating the outboard motor. Failure to do so could result in personal injury or equipment damage.**



Shift to the neutral position and then shift to the reverse position at low engine speed. Do not shift to the reverse position suddenly at high engine speed.

- Gasoline is harmful or fatal if swallowed. Keep the fuel tank out of reach of children.
- Gasoline is extremely flammable and is explosive under certain conditions. Refuel in a well-ventilated area with the engine stopped.
- Do not smoke or allow flames or sparks where the engine is refueled or where gasoline is stored.
- Do not overfill the fuel tank. After refueling make sure that the fuel tank cap is closed properly and securely.

- Be careful not to spill any fuel while refueling. Spilled fuel or fuel vapor may ignite. If any fuel is spilled make sure that the area is dry before starting the engine.
- Know how to stop the engine quickly in case of emergency. Understand the use of all controls.
- Do not exceed the boat manufacturer's power recommendation, and be sure that the outboard motor is properly mounted.
- Never permit anyone to operate the outboard motor without proper instruction.
- Stop the engine immediately if anyone falls overboard.
- Do not run the engine while the boat is near anyone in the water.
- Attach the emergency stop switch lanyard securely to the operator.
- Before operating the outboard motor, familiarize yourself with all laws and regulations relating to boating and the use of outboard motors.

- Do not attempt to modify the outboard motor.
- Always wear a life-jacket when on board.
- Do not operate the outboard motor without the engine cover. Exposed moving parts can cause injury.
- Do not remove any guards, labels, shields, covers or safety devices; they are installed for your safety.

Burn Hazards

The engine and exhaust system become very hot during operation and remain hot for a while after stopping. Contact with hot engine components can cause burns and may ignite some materials.

- Avoid touching a hot engine or exhaust system.
- Allow the engine to cool before performing maintenance or transporting.

Carbon Monoxide Poisoning Hazard

Exhaust contains poisonous carbon monoxide, a colorless and odorless gas. Breathing exhaust can cause loss of consciousness and may lead to death.

- If you run the engine in an area that is confined, or even partially enclosed, the air can become contaminated with a dangerous amount of exhaust gas. To keep exhaust gas from building up, provide adequate ventilation.

2. SAFETY LABEL LOCATIONS

These labels are in the locations shown.

They warn you of potential hazards that can cause serious injury.

The label is considered permanent part of your outboard motor.

Read the labels and safety notes and precautions described in this manual carefully.

If a label comes off or becomes hard to read, contact your Honda outboard motor dealer for a replacement.

READ OWNER'S MANUAL GEAR SHIFTING

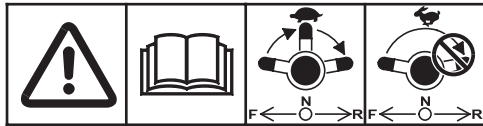

SAFETY LABEL LOCATIONS

CE mark/UKCA mark location [European types]

CE MARK/UKCA MARK

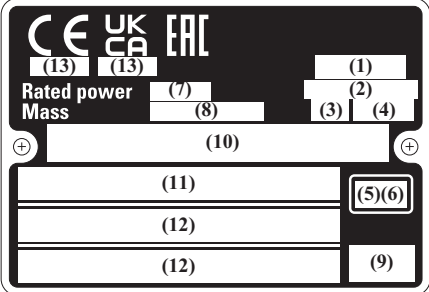

(1) Model name
 (2) Engine family name
 (3) Minor model change code
 (4) Type name
 (5) Year code
 (6) Month code
 (7) Rated power
 (8) Dry mass (weight) (with propeller)
 (9) Country of manufacture
 (10) Frame serial number (Type and serial number of Declaration of Conformity)
 (11) Manufacture and address
 (12) Name and address of authorized representative
 (13) The identification number of the notified body

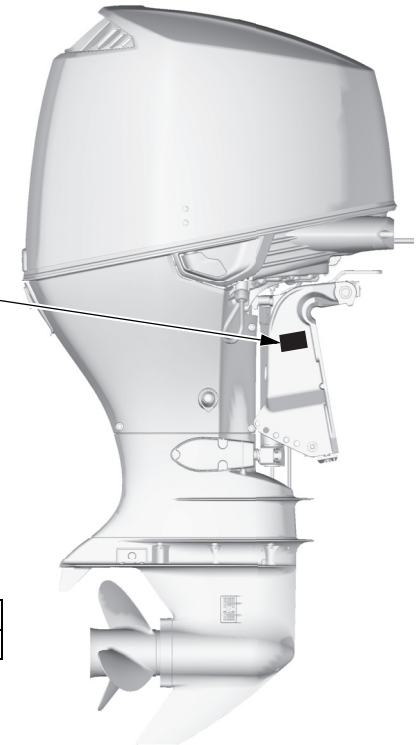

Year code	M	N	P	R	S	T	U	V	W	X
Year of manufacture	2021	2022	2023	2024	2025	2026	2027	2028	2029	2030

Month code	A	B	C	D	E	F	G	H	J	K	L	M
Month of manufacture	1	2	3	4	5	6	7	8	9	10	11	12

Name and address of manufacturer and authorized representative and importer are written in the “Declaration of Conformity” CONTENT OUTLINE in this Owner’s Manual.

3. COMPONENT IDENTIFICATION

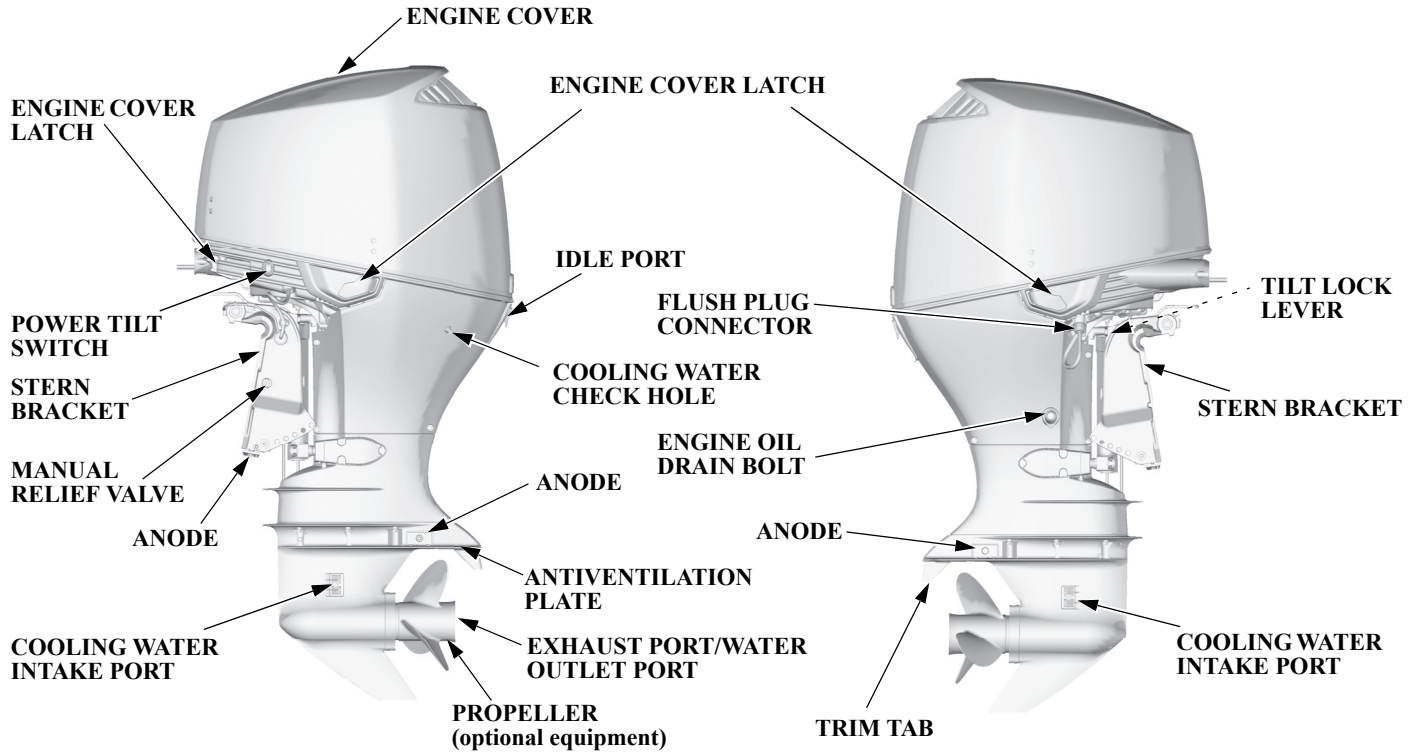

COMPONENT IDENTIFICATION

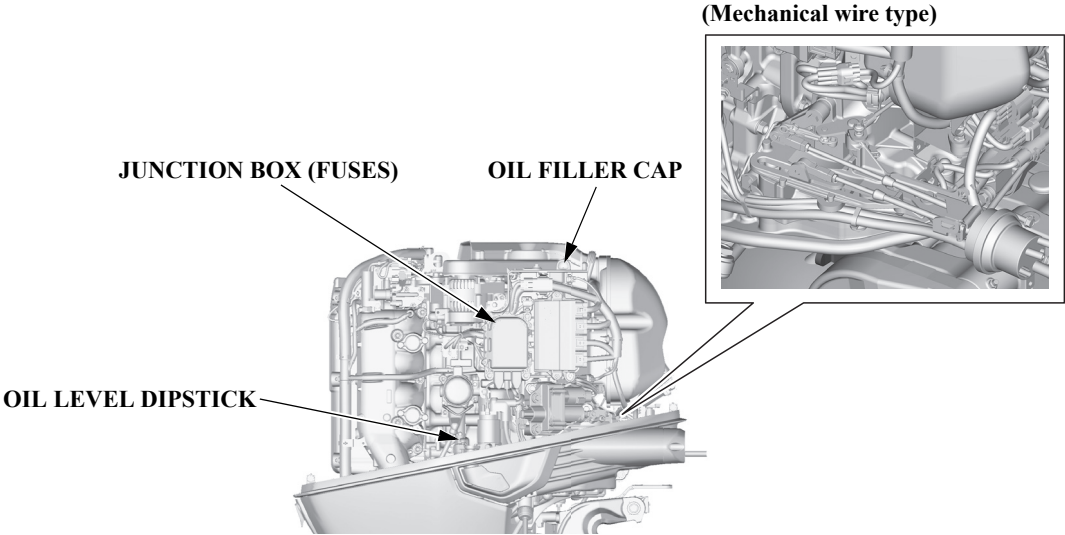

COMPONENT IDENTIFICATION

(Mechanical wire type)

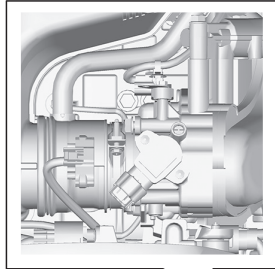

FUEL FILTER WITH WATER SEPARATOR

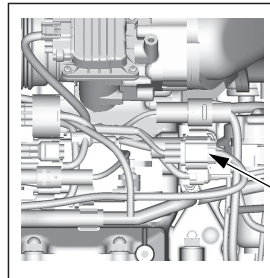

NMEA INTERFACE COUPLER

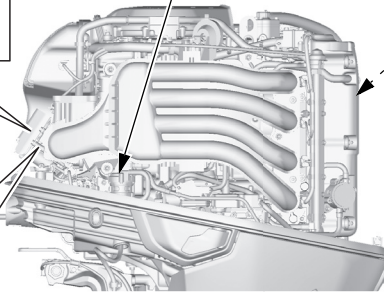

**SPARK PLUG
(under coil)**

COMPONENT IDENTIFICATION

DBW REMOTE CONTROL BOX (optional equipment)

FLUSH-MOUNT TYPE (D1 type)

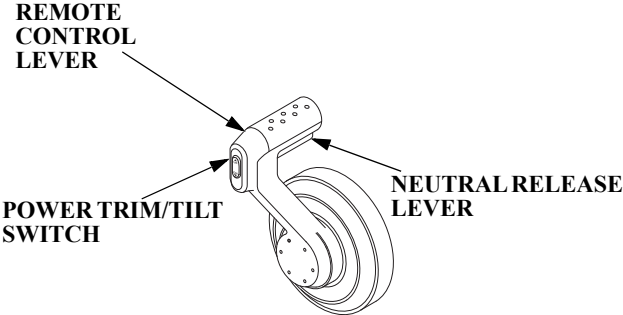

TOP-MOUNT TYPE (D2 type) (SINGLE OUTBOARD MOTOR TYPE)

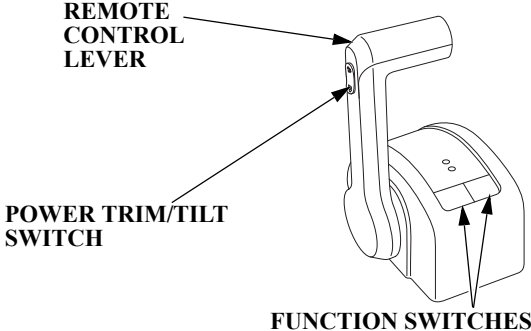

(DUAL OUTBOARD MOTOR TYPE)

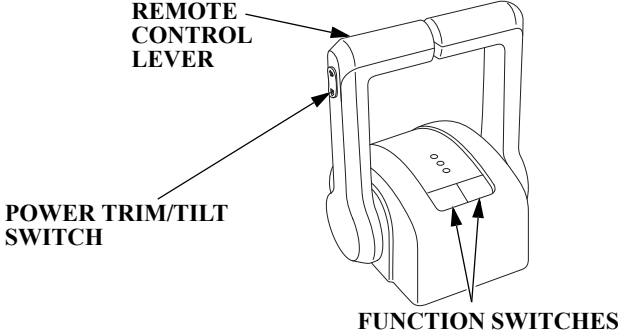

COMPONENT IDENTIFICATION

KEY SWITCH PANEL (optional equipment)

(Normal Key with START/STOP switch type)
(Horizontal type)

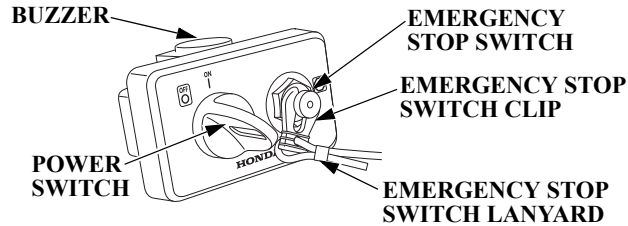

(Normal Key without START/STOP switch type)
(Horizontal type)

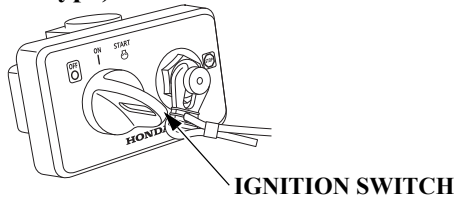

(Honda Smart Key type)
(Horizontal type)

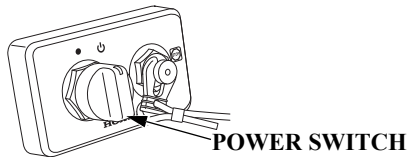

START/STOP SWITCH PANEL (optional equipment)

START/STOP SWITCH

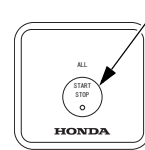

ALL ENGINE START
FOR MULTIPLE
OUTBOARD MOTORS

START/STOP SWITCH

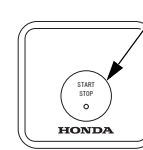

SINGLE TYPE
OUTBOARD MOTOR

START/STOP SWITCH

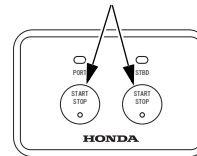

DUAL TYPE
OUTBOARD MOTOR

START/STOP SWITCH

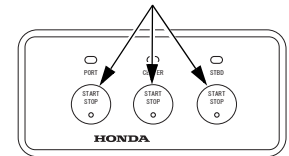

TRIPLE TYPE
OUTBOARD MOTOR

PORT: Port side engine
CENTER: Center engine
STBD: Starboard side engine

COMPONENT IDENTIFICATION

PTT SWITCH PANEL (optional equipment)

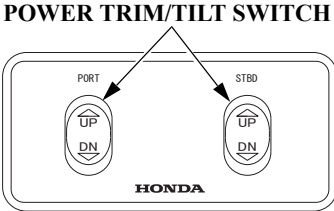

DUAL TYPE

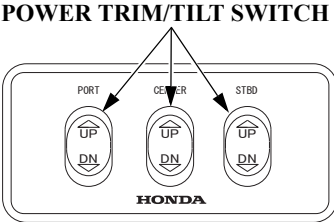

TRIPLE TYPE

PORT: Port side engine
CENTER: Center engine
STBD: Starboard side engine

FUNCTION SWITCH PANEL (optional equipment) (for FLUSH-MOUNT type)

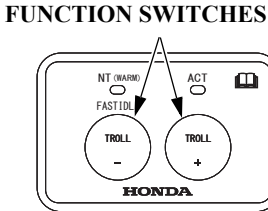

EMERGENCY STOP SWITCH PANEL (optional equipment)

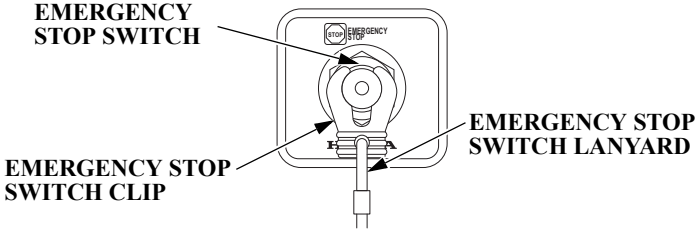

DISPLAY ASSY (optional equipment)



COMPONENT IDENTIFICATION

REMOTE CONTROL BOX (optional equipment)

SIDE-MOUNT TYPE (R1 type)

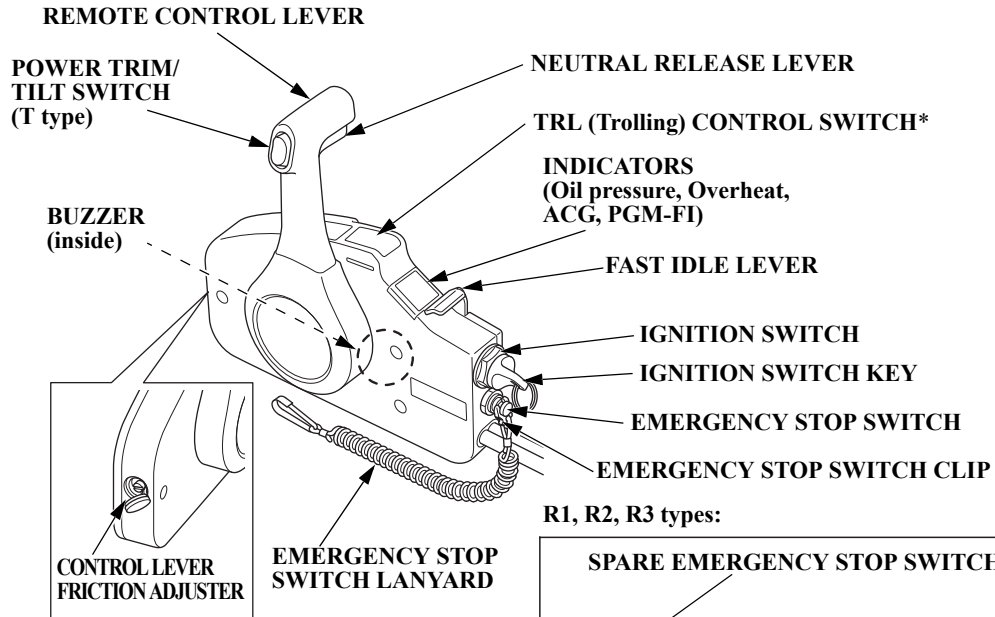

* For TRL (Trolling) control switch equipped type.

COMPONENT IDENTIFICATION

FLUSH-MOUNT TYPE (R2 type)

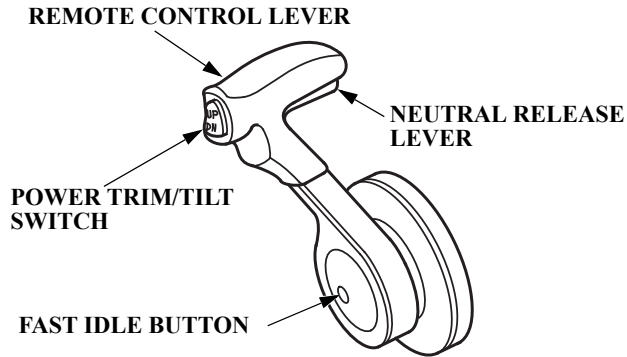

TOP-MOUNT TYPE (R3 type) (SINGLE OUTBOARD MOTOR TYPE)

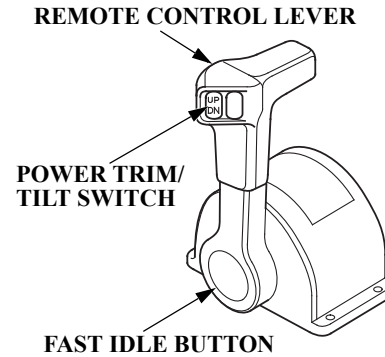

(DUAL OUTBOARD MOTOR TYPE)

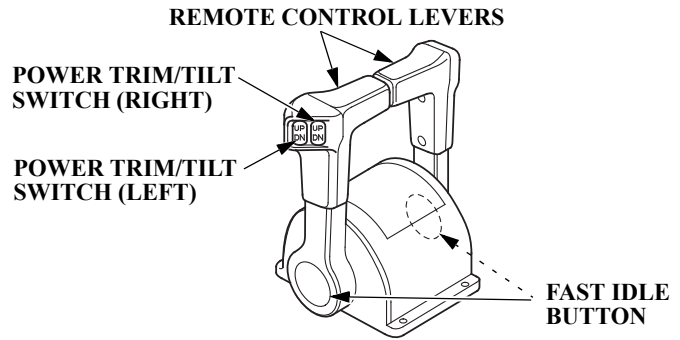

COMPONENT IDENTIFICATION

SWITCH PANEL (optional equipment) (FLUSH-MOUNT, TOP-MOUNT)

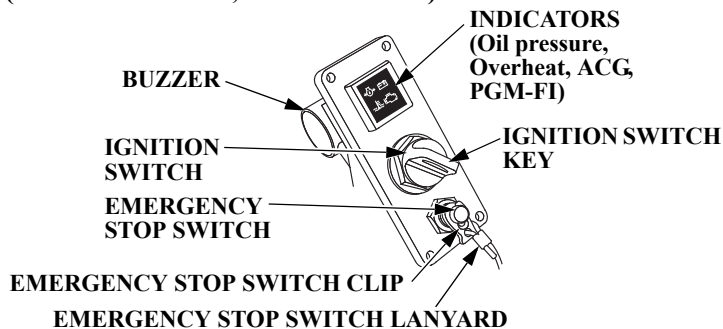

SWITCH PANEL without indicators type (optional equipment) (FLUSH-MOUNT, TOP-MOUNT SINGLE)

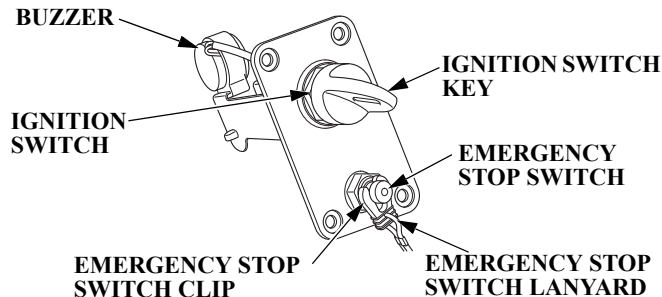

(for DUAL OUTBOARD MOTORS type)

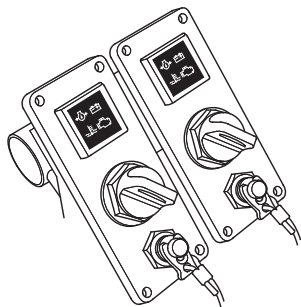

(for DUAL OUTBOARD MOTORS type)

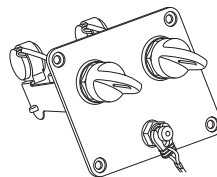

(for TRIPLE OUTBOARD MOTORS type)

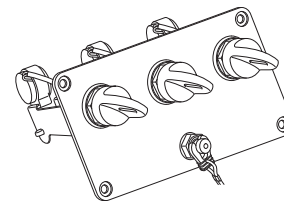

For the switch panel without indicators type, use it along with the NMEA2000-compatible device.

COMPONENT IDENTIFICATION

(Common)

TACHOMETER
(optional equipment)

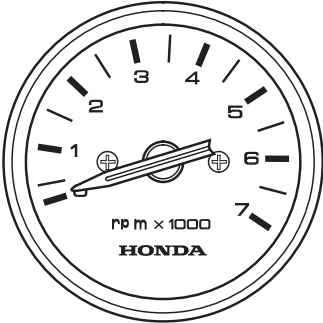

TRIM METER
(optional equipment)

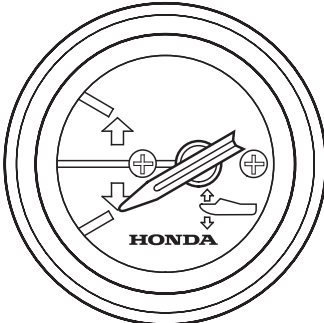

TRL (Trolling) CONTROL SWITCH PANEL
(optional equipment)

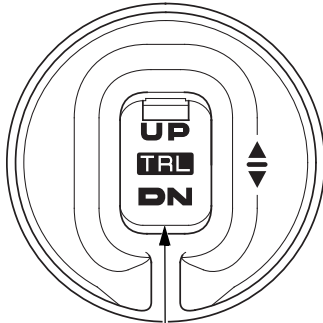

TRL (Trolling) CONTROL SWITCH

4. CONTROLS AND FEATURES

Remote Control Lever (D1 type)

REMOTE CONTROL LEVER

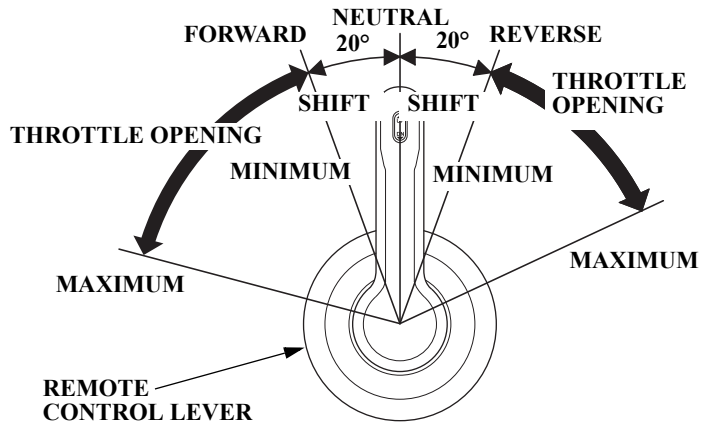
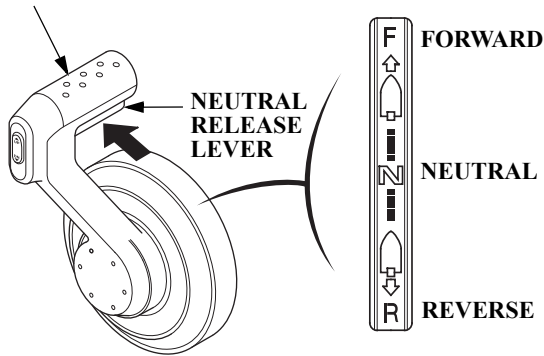

Shifting gear into forward, reverse, or neutral and the engine speed adjustment can be performed with the remote control lever.

It is necessary to pull up the neutral release lever to operate the remote control lever.

FORWARD:

Moving the lever to the FORWARD position (i.e. approximately 20° from the NEUTRAL position) engages the gear into forward. Moving the lever further from the FORWARD position will increase the throttle opening and the boat forward speed.

NEUTRAL:

Engine power is cut off from the propeller.

REVERSE:

Moving the lever to the REVERSE position (i.e. approximately 20° from the NEUTRAL position) engages the gear into reverse. Moving the lever further from the REVERSE position will increase the throttle opening and the boat reverse speed.

CONTROLS AND FEATURES

Remote Control Lever (D2 type)

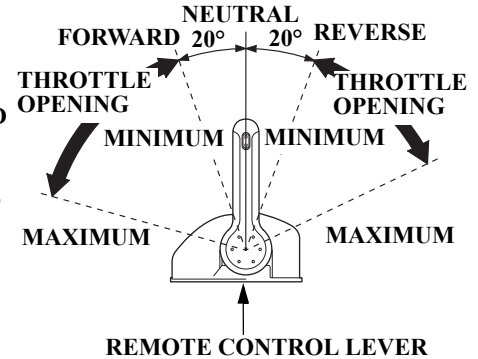
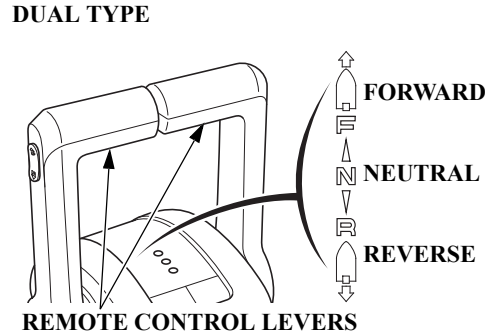
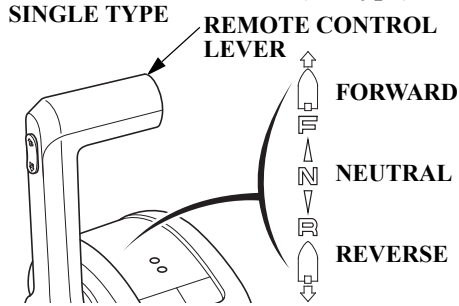

Shifting gear into forward, reverse, or neutral and the engine speed adjustment can be performed with the remote control lever.

FORWARD:
Moving the lever to the FORWARD position (i.e. approximately 20° from the NEUTRAL position) engages the gear into forward. Moving the lever further from the FORWARD position will increase the throttle opening and the boat forward speed.

NEUTRAL:
Engine power is cut off from the propeller.

REVERSE:
Moving the lever to the REVERSE position (i.e. approximately 20° from the NEUTRAL position) engages the gear into reverse. Moving the lever further from the REVERSE position will increase the throttle opening and the boat reverse speed.

CONTROLS AND FEATURES

Remote Control Lever (R1 type)

REMOTE CONTROL LEVER

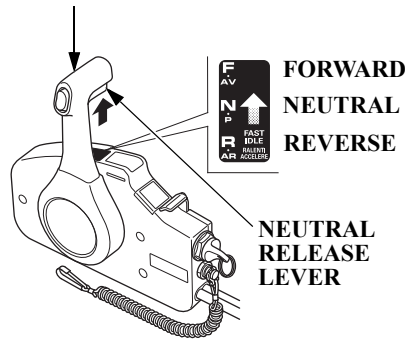

Shifting gear into forward, reverse, or neutral and the engine speed adjustment can be performed with the remote control lever.

It is necessary to pull up the neutral release lever to operate the remote control lever.

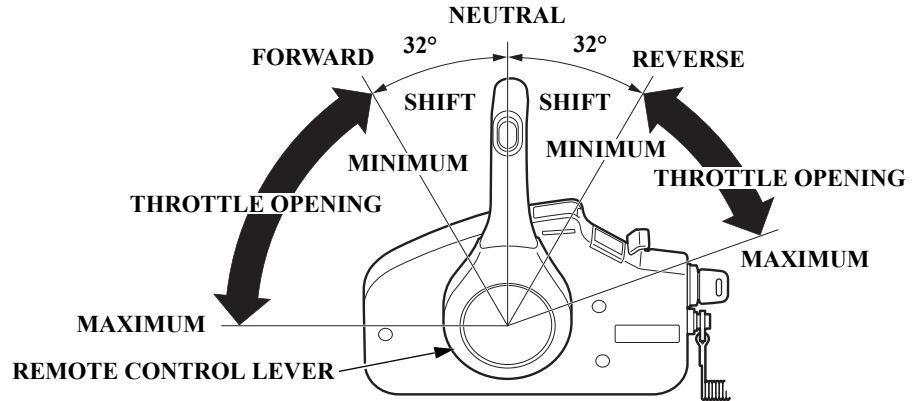

FORWARD:

Moving the lever to the FORWARD position (i.e. approximately 32° from the NEUTRAL position) engages the gear into forward. Moving the lever further from the FORWARD position will increase the throttle opening and the boat forward speed.

NEUTRAL:

Engine power is cut off from the propeller.

REVERSE:

Moving the lever to the REVERSE position (i.e. approximately 32° from the NEUTRAL position) engages the gear into reverse. Moving the lever further from the REVERSE position will increase the throttle opening and the boat reverse speed.

CONTROLS AND FEATURES

Remote Control Lever (R2 type)

REMOTE CONTROL LEVER

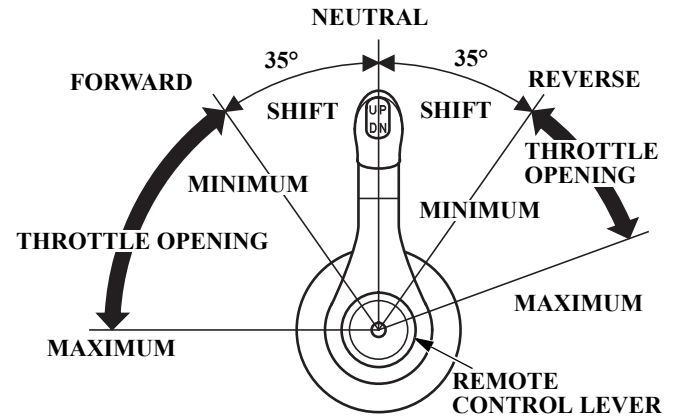
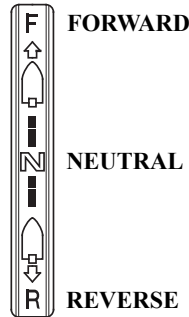
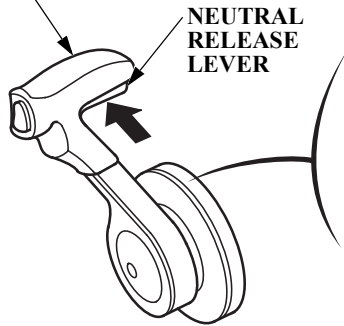

Shifting gear into forward, reverse, or neutral and the engine speed adjustment can be performed with the remote control lever.

It is necessary to pull up the neutral release lever to operate the remote control lever.

FORWARD:

Moving the lever to the FORWARD position (i.e. approximately 35° from the NEUTRAL position) engages the gear into forward. Moving the lever further from the FORWARD position will increase the throttle opening and the boat forward speed.

NEUTRAL:

Engine power is cut off from the propeller.

REVERSE:

Moving the lever to the REVERSE position (i.e. approximately 35° from the NEUTRAL position) engages the gear into reverse. Moving the lever further from the REVERSE position will increase the throttle opening and the boat reverse speed.

CONTROLS AND FEATURES

Remote Control Lever (R3 type)

SINGLE TYPE

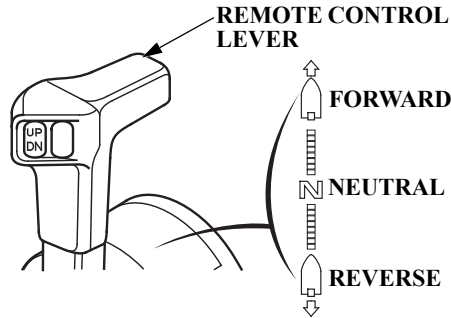

DUAL TYPE

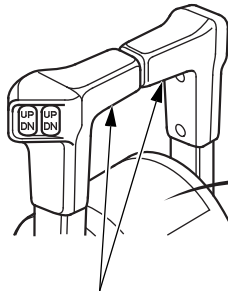

FORWARD

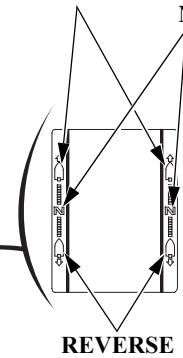

NEUTRAL

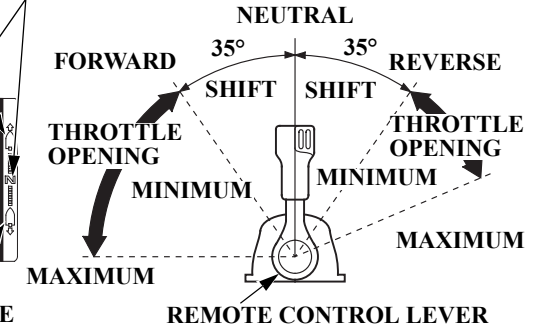

REMOTE CONTROL LEVERS

Shifting gear into forward, reverse, or neutral and the engine speed adjustment can be performed with the remote control lever.

FORWARD:

Moving the lever to the FORWARD position (i.e. approximately 35° from the NEUTRAL position) engages the gear into forward. Moving the lever further from the FORWARD position will increase the throttle opening and the boat forward speed.

NEUTRAL:

Engine power is cut off from the propeller.

REVERSE:

Moving the lever to the REVERSE position (i.e. approximately 35° from the NEUTRAL position) engages the gear into reverse. Moving the lever further from the REVERSE position will increase the throttle opening and the boat reverse speed.

CONTROLS AND FEATURES

Neutral Release Lever

(D1 type)

REMOTE CONTROL LEVER

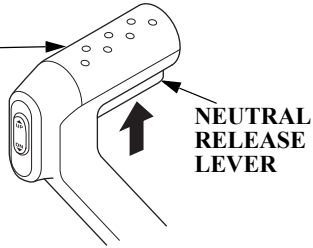

(R1 type)

REMOTE CONTROL LEVER

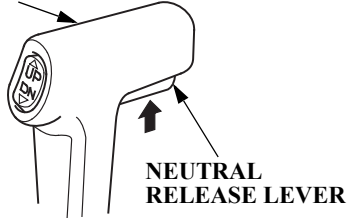

(R2 type)

REMOTE CONTROL LEVER

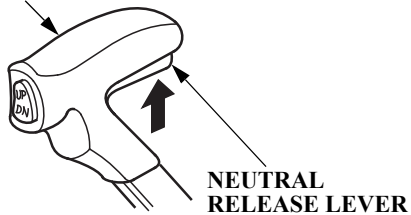

The neutral release lever is set on the remote control lever to prevent an accidental operation of the remote control lever.

The remote control lever does not operate unless it is moved while pulling the neutral release lever up.

CONTROLS AND FEATURES

Ignition Switch (R1 type)

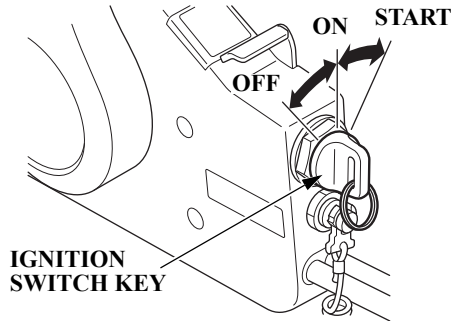

This remote control is equipped with an automotive type ignition switch. On the flush-mount type (D1 type), the top-mount type (D2 type), the engine switch locates on the key switch panel.

(D1, D2 without START/STOP Switch types) (R2, R3 types)

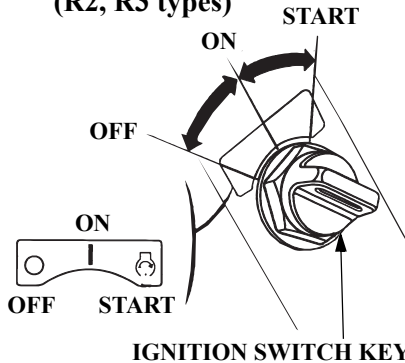

On the side-mount type (R1 type), the ignition switch locates on your side near the remote control box. On the flush-mount type (R2 type) and the top-mount type (R3 type), the ignition switch locates at the center of the switch panel.

Key positions:

- START: to start the engine.
- ON: to run the engine after starting.
- OFF: to stop the engine (IGNITION OFF).

NOTICE

Do not leave the ignition switch (ignition switch) ON (key in ON position) when the engine is not running as the battery will discharge.

NOTE:

The starter motor will not work unless the remote control lever is in the NEUTRAL position, and the clip is in the emergency stop switch.

Power Switch (Normal Key type)

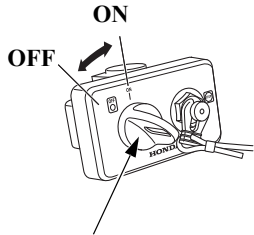

POWER SWITCH

Power Switch (Honda Smart Key type)

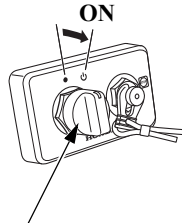

POWER SWITCH

This remote control is equipped with a start/stop switch.

<Normal Key Type>

ON: This position allows the engine to start and run.

OFF: This position stops the engine (Ignition OFF).

<Honda Smart Key Type>

Turn the power switch clockwise and then release to turn the power ON.

Turn and release the power switch again to turn the power OFF.

NOTICE

Turn the power off after the engine is stopped. If the power is not turned off after the engine is stopped, the battery will continue to drain until it is depleted.

NOTE:

For the Honda Smart Key type, electrical power cannot be supplied to the boat unless the Smart Key and remote control are properly paired (authenticated).

Honda Smart Key (optional equipment)

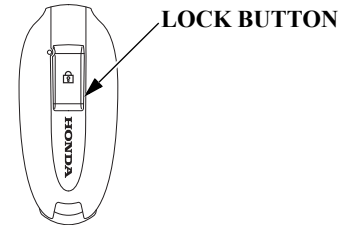

The Honda Smart Key has an immobilizer system. The immobilizer system helps to protect against boat theft. Refer to the Honda Smart Key Owner's Manual for complete information on the Smart Key system.

The Honda Smart Key is available in certain areas.

CONTROLS AND FEATURES

START/STOP SWITCH

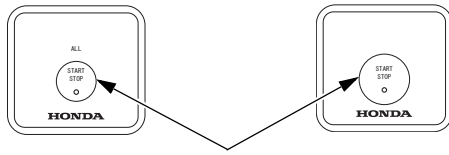

START/STOP SWITCH

**ALL ENGINE START
FOR MULTIPLE
OUTBOARD MOTORS**

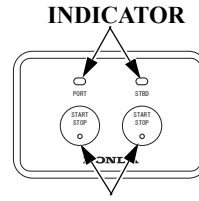

START/STOP SWITCH

**DUAL TYPE
OUTBOARD MOTORS**

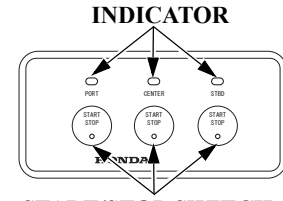

START/STOP SWITCH

**TRIPLE TYPE
OUTBOARD MOTORS**

To start the engine, be sure the power switch is in the ON position, and then press the start/stop switch button.

For boats with multiple outboard motors and equipped with the All Engine Start key switch, all motors can be started at the same time at the press of one button.

For boats equipped with multiple outboard motors and either the Dual Type or Triple Type key switches, each outboard on the boat may be started individually and the corresponding indicator light will turn on after the engine has started.

NOTE:

The starter motor will not work unless the remote control lever is in the NEUTRAL position, and the clip is in the emergency stop switch.

FUNCTION SWITCHES (D1 type)

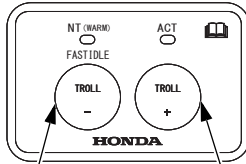

[-] SWITCH

[+] SWITCH

Function switches are used for operations in the fast idle mode and trolling mode.

NT (WARM)

Lights: The shift is in neutral.

Blinks: It is in the fast idle mode.

ACT

Lights: The shift and throttle operations are possible.

Off: The shift and throttle operations are not possible.

<Fast Idle Mode>

The fast idle mode is only needed for starting carbureted outboard models. The BF115J/135D/150D models use programmed fuel injection so, this mode will not be needed for starting.

After the engine starts and if the outside temperature is below 5°C (41°F), the fast idle mode can be used to accelerate engine warm up.

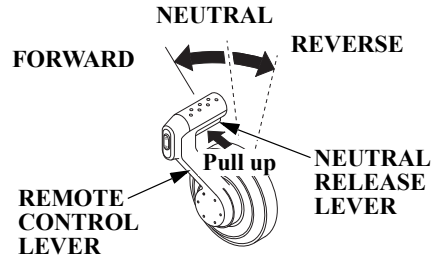

Use the [-] switch and the remote control lever to adjust the engine speed without gearshift when warming up the engine. Keeping the [-] switch pressed when the remote control lever is in the NEUTRAL position, turn the lever forward. Keep turning the lever forward. The throttle opens and the engine speed increases after the lever passed the shift point.

Note that the gearshift mechanism does not function when the [-] switch is pushed once and then released after the remote control lever is moved. The control lever does not operate unless the neutral release lever is pulled.

To release the fast idle mode, press and hold the [-] switch.

CONTROLS AND FEATURES

<Trolling Mode>

The engine speed can be adjusted with the [-] switch and [+] switch when in trolling mode.

If you press and hold the [+] switch while cruising with the throttle closed, the mode changes to trolling mode.

Engine speed adjusting range:

650 min⁻¹ (rpm) – 900 min⁻¹ (rpm)
(every 50 min⁻¹ (rpm))

To release the trolling mode, press and hold the [+] switch.

FUNCTION SWITCHES (D2 type)

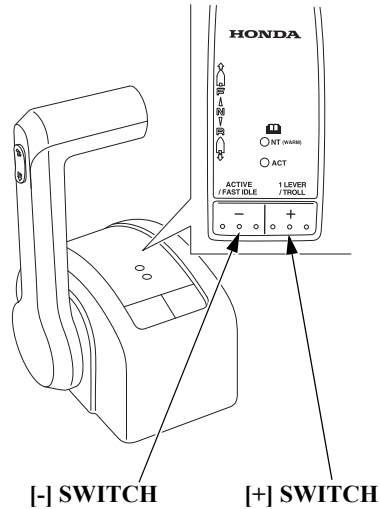

Function switches are used for operations in the fast idle mode, trolling mode, one-lever mode and station select mode.

NT (WARM)

Lights: The shift is in neutral.

Blinks: It is in the fast idle mode.

ACT

Lights: The shift and throttle operations are possible.

Off: The shift and throttle operations are not possible.

<Fast Idle Mode>

The fast idle mode is only needed for starting carbureted outboard models. The BF115J/135D/150D models use programmed fuel injection so, this mode will not be needed for starting.

After the engine starts and if the outside temperature is below 5°C (41°F), the fast idle mode can be used to accelerate engine warm up.

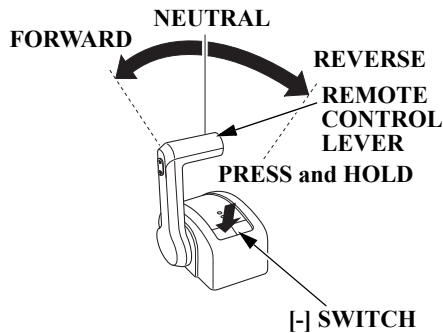

Use the [-] switch and the remote control lever to adjust the engine speed without gearshift when warming up the engine. Keeping the [-] switch pressed when the remote control lever is in the NEUTRAL position, turn the lever forward. Keep turning the lever forward. The throttle opens and the engine speed increases after the lever passed the shift point. Note that the gearshift mechanism does not function when the [-] switch is pushed once and then released after the remote control lever is moved.

To release the fast idle mode, press and hold the [-] switch.

<Trolling Mode>

The engine speed can be adjusted with the [-] switch and [+] switch when in trolling mode. If you press and hold the [+] switch while cruising with the throttle closed, the mode changes to trolling mode.

Engine speed adjusting range:

650 min⁻¹ (rpm) – 900 min⁻¹ (rpm)
(every 50 min⁻¹ (rpm))

To release the trolling mode, press and hold the [+] switch.

<One-Lever Mode>

(For multiple outboard motors type)
Shifting gear and the engine speed adjustment of the all outboard motors can be performed with one remote control lever when in one-lever mode.

If you press and hold the [+] switch when all remote control lever is in the NEUTRAL position, the mode changes to one-lever mode. To release one-lever mode, press and hold the [+] switch.

<Station Select Mode>

For multiple station type, use the [-] switch to change the operating station.

If you press and hold the [-] switch of the inactive station when all remote control lever is in the NEUTRAL position, you can operate the outboard motors using this station.

CONTROLS AND FEATURES

Fast Idle Lever (R1 type)/Fast Idle Button (R2, R3 types)

The fast idle lever/fast idle button is only needed for starting carbureted outboard model. The BF115J/135D/150D models use programmed fuel injection so, this lever will not be needed for starting.

After the engine starts and if the outside temperature is below 5°C (41°F), the fast idle lever/fast idle button can be used to accelerate engine warm up.

<Fast Idle Lever> (R1 type)

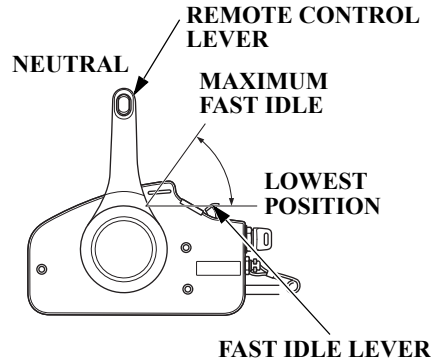

The fast idle lever will not move unless the remote control lever is in the NEUTRAL position. Conversely, the remote control lever will not move unless the fast idle lever is in the lowest position.

Lower the fast idle lever to the lowest position to decrease the fast idle.

<Fast Idle Button> (R2 type)

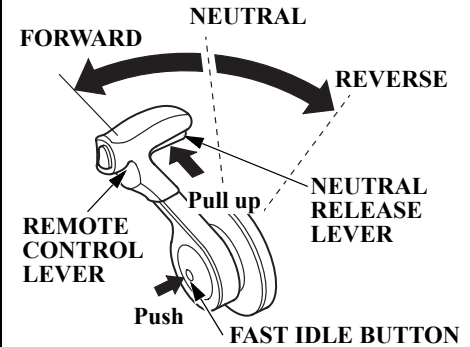

Pushing the fast idle button, turn the remote control lever forward. Keep turning the lever forward. The throttle opens and the engine speed increases after the lever passed the shift point. Note that the gearshift mechanism does not function when the fast idle button is pushed once and then released after the remote control lever is moved.

The control lever does not operate unless the neutral release lever is pulled.

<Fast Idle Button> (R3 type)

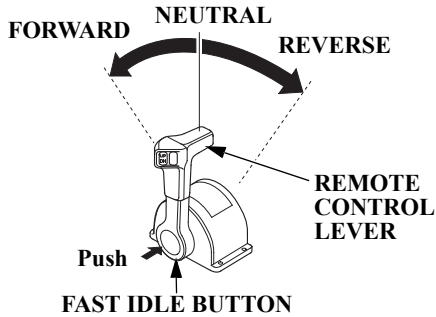

Use the fast idle button and the remote control lever to adjust the engine speed without gearshift when warming up the engine. Pushing the fast idle button, turn the remote control lever forward. Keep turning the lever forward. The throttle opens and the engine speed increases after the lever passed the shift point. Note that the gearshift mechanism does not function when the fast idle button is pushed once and then released after the remote control lever is moved.

PGM-FI Indicator/Buzzer (R1 type)

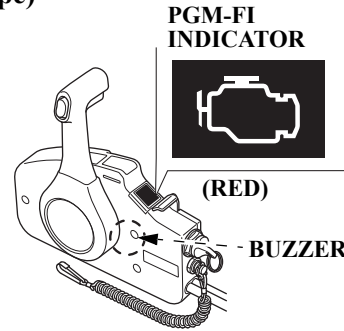

(R2, R3 types)

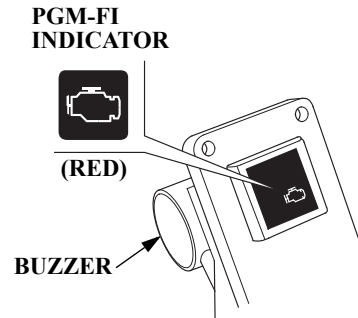

(optional equipment)

Display assy

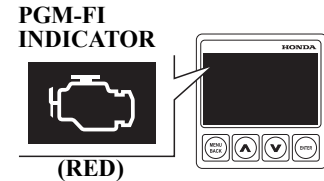

The PGM-FI indicator turns on and the buzzer sounds when the engine control system is faulty. If using a flush-mount or top-mount switch panel without indicators, check the indicators displayed on an NMEA2000-compatible device. For information about NMEA2000-compatible device displays, refer to the display device's manual.

CONTROLS AND FEATURES

ACG Indicator/Buzzer (R1 type)

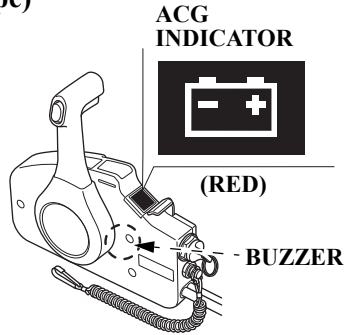

(R2, R3 types)

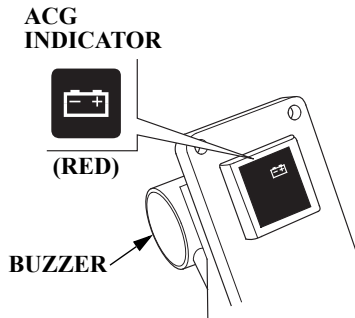

(optional equipment)

Display assy

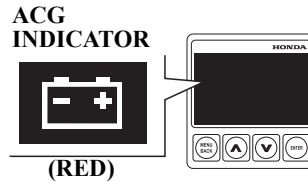

The ACG indicator turns on and the buzzer sounds when the charging system is faulty.
If using a flush-mount or top-mount switch panel without indicators, check the indicators displayed on an NMEA2000-compatible device.
For information about NMEA2000-compatible device displays, refer to the display device's manual.

Oil Pressure Indicator/Buzzer (R1 type)

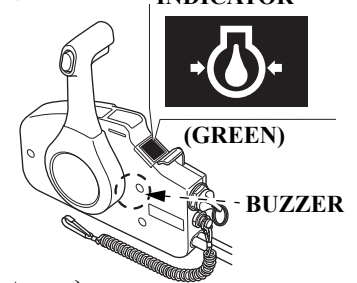

(R2, R3 types) OIL PRESSURE INDICATOR

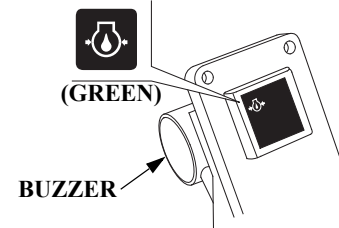

(optional equipment)

Display assy

OIL PRESSURE INDICATOR

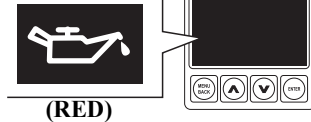

The oil pressure indicator turns off and the buzzer sounds when the oil level is low and/or the engine lubrication system is faulty.

The engine speed slows down gradually this time.

If using a flush-mount or top-mount switch panel without indicators, check the indicators displayed on an NMEA2000-compatible device.

For information about NMEA2000-compatible device displays, refer to the display device's manual.

Overheat Indicator/Buzzer

(R1 type)

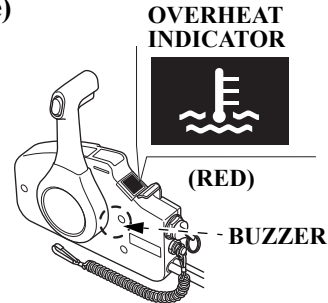

(R2, R3 types)

OVERHEAT INDICATOR

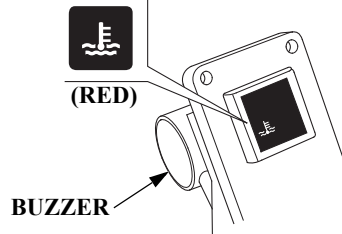

(optional equipment)

Display assy

OVERHEAT INDICATOR



The overheat indicator turns on and the buzzer sounds when the engine cooling circuit is faulty. The engine speed slows down this time.

If using a flush-mount or top-mount switch panel without indicators, check the indicators displayed on an NMEA2000-compatible device.

For information about NMEA2000-compatible device displays, refer to the display device's manual.

Water Separator Buzzer

The water separator buzzer sounds when water has accumulated in the water separator.

CONTROLS AND FEATURES

Power Trim/Tilt Switch

Power Trim

Press the power trim/tilt switch on the remote control lever to adjust the outboard motor trim angle of -4° to 16° to maintain proper boat trim. The power trim/tilt switch can be operated while the boat is under way or while stopped.

By using the power trim/tilt switch the operator can change the trim angle of the outboard motor to achieve maximum boat acceleration, speed, stability and maintain optimum fuel consumption.

NOTE:

The outboard motor trim angle of -4° to 16° is the angle when the outboard motor is installed on the boat at 12° .

(R1 type)

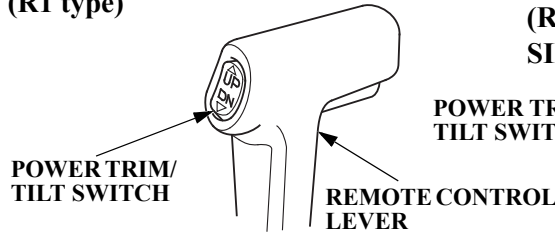

(R3 type)
SINGLE TYPE

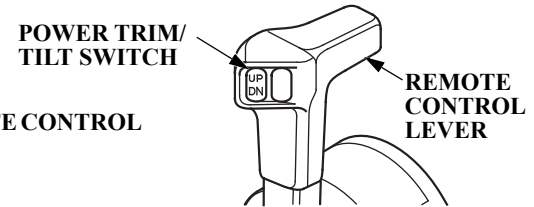

(R2 type)

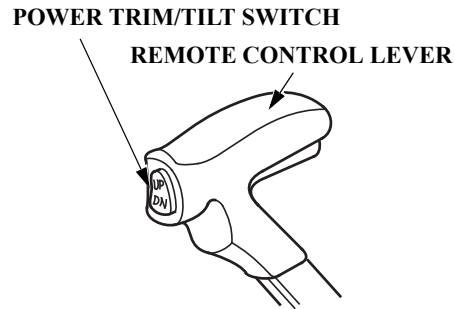

DUAL TYPE
POWER TRIM/TILT SWITCH
(LEFT) (RIGHT)

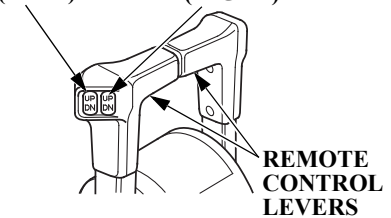

NOTICE

Excessive trim/tilt angle during operation can cause the propeller to raise out of the water and cause propeller ventilation and engine over-revving. Excessive trim/tilt angle can also damage the water pump.

CONTROLS AND FEATURES

(D1 type)

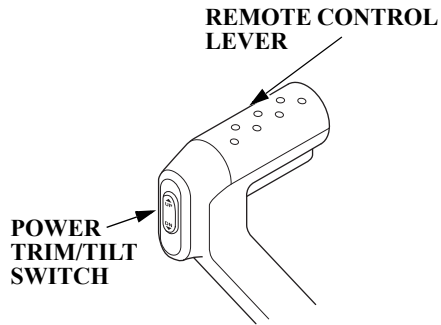

(D2 type)

SINGLE TYPE

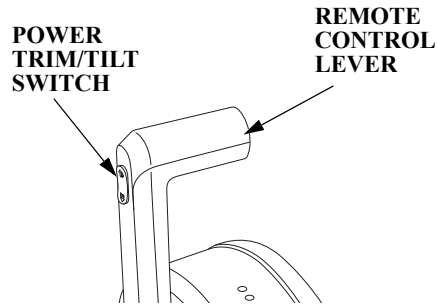

DUAL TYPE

POWER TRIM/TILT SWITCH

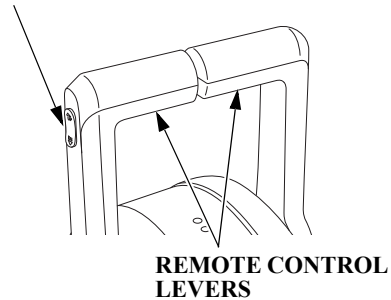

PTT SWITCH PANEL

DUAL TYPE

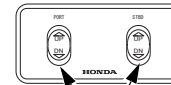

TRIPLE TYPE

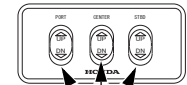

POWER TRIM/TILT SWITCH

NOTE:

For multiple outboard motors, the trim/tilt angle of all outboard motors is adjusted at the same time by using the power trim/tilt switch on the remote control lever and the trim/tilt angle of each outboard motor is adjusted by using each power trim/tilt switch on the panel.

CONTROLS AND FEATURES

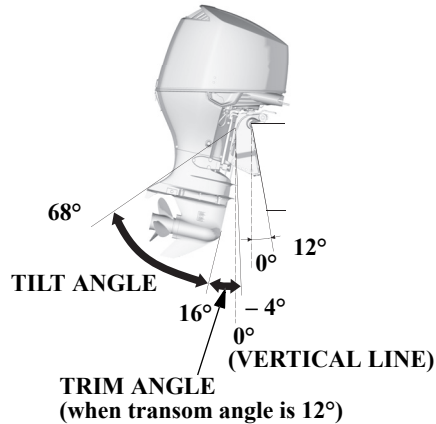

Power Tilt

Press the power trim/tilt switch to adjust the outboard motor tilt angle of 16° to 68°.

By using the power trim/tilt switch the operator can change the tilt angle of the outboard motor for shallow water operation, beaching, launching from a trailer, or mooring. Please tilt up simultaneously, when you mount the dual type outboard motor.

Trim Meter (optional equipment)

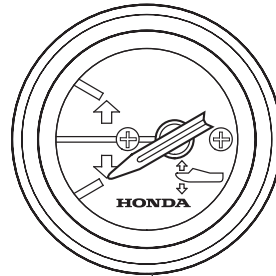

TRIM METER

The trim meter has a range of -4° to 16° and indicates the trim angle of the outboard motor. Refer to the trim meter when using the power trim/tilt switch to achieve proper boat performance.

NOTE:

The outboard motor trim angle of -4° to 16° is the angle when the outboard motor is installed on the boat at 12°.

Power Tilt Switch (outboard motor pan)

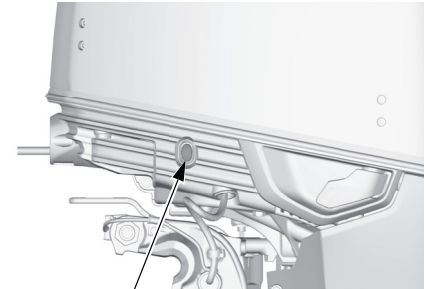

POWER TILT SWITCH

The power tilt switch located on the outboard motor pan is a convenience switch for tilting the outboard motor for trailering, or performing outboard maintenance. This power tilt switch should only be operated with the boat being stopped and engine off.

TRL (Trolling) Control Switch

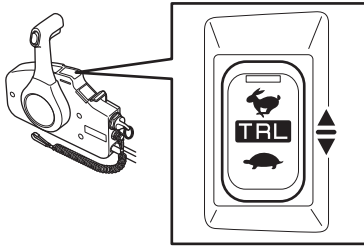

TRL (Trolling)
CONTROL SWITCH

Remote Control Box (Side-mount type)

For TRL (Trolling) control switch equipped type.

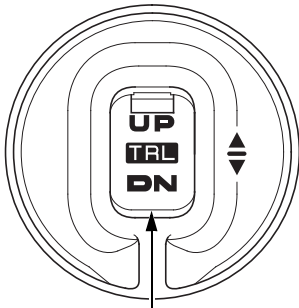

TRL (Trolling) CONTROL SWITCH

TRL (Trolling) Control Switch Panel (optional equipment)

The engine speed can be adjusted with the trolling control switch when in trolling mode.

If you press and hold the TRL control switch while cruising with the throttle closed, the mode changes to trolling mode.

Manual Relief Valve

MANUAL RELIEF VALVE

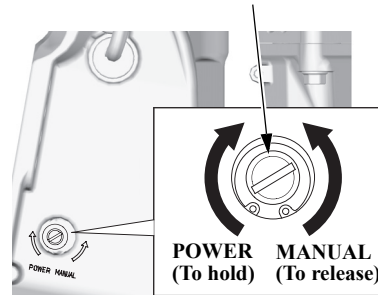

If the power trim/tilt switch will not tilt the outboard motor, the outboard motor can be manually tilted up or down by opening the manual relief valve. To tilt the outboard motor manually, turn the manual relief valve under the left stern bracket no more than 1 or 2 turns counterclockwise using a screwdriver.

After tilting the outboard motor, turn the manual relief valve clockwise securely.

Check that no person is under the outboard motor before carrying out this position because if the manual relief valve is loosened (turned counterclockwise) when the outboard motor is tilted up, the outboard motor will suddenly tilt down.

The manual relief valve must be tightened securely before operating the outboard motor or the outboard motor could tilt up when operating in reverse.

CONTROLS AND FEATURES

Emergency Stop Switch

The emergency stop switch lanyard is provided to stop the engine immediately in the event the operator should fall overboard or away from the controls.

When using the switch panel without indicators type, pull the emergency stop switch clip out of the emergency stop switch (see page 112).

(D1, D2 types)

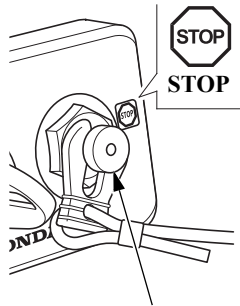

EMERGENCY STOP SWITCH

(R1 type)

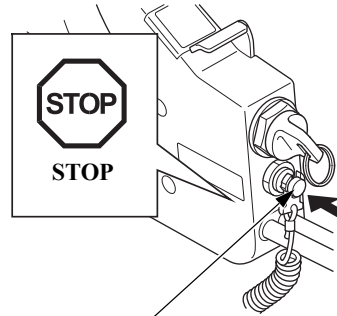

EMERGENCY STOP SWITCH

(R2, R3 types)

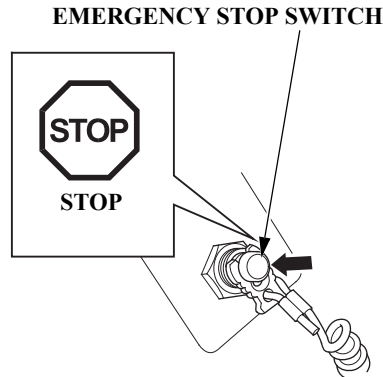

EMERGENCY STOP SWITCH

Emergency Stop Switch Lanyard/Clip

EMERGENCY STOP SWITCH LANYARD

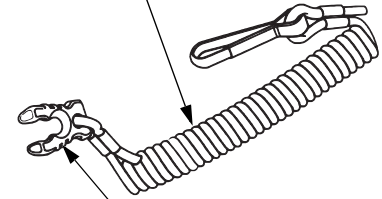

EMERGENCY STOP SWITCH CLIP

The emergency stop switch clip must be engaged with the engine stop switch or the engine will not start. When the emergency stop switch clip becomes disengaged with the emergency stop switch the engine will stop immediately.

⚠ WARNING

If the emergency stop switch lanyard is not set, the boat might run out of control when the operator, for example, falls overboard and is not able to operate the outboard motor.

For the sake of the operator's and the passenger's safety, be sure to set the emergency stop switch clip located at one end of the emergency stop switch lanyard with the emergency stop switch. Attach the other end of the emergency stop switch lanyard securely to the operator.

(D1, D2 types)

EMERGENCY STOP SWITCH

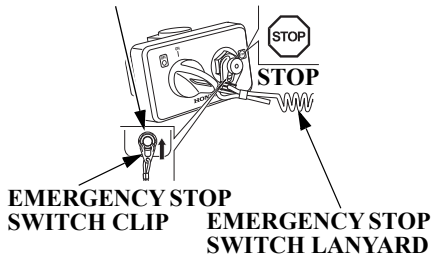

(R1 type)

EMERGENCY STOP SWITCH

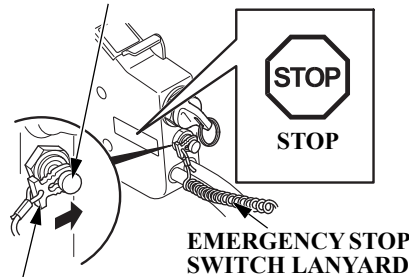

EMERGENCY STOP SWITCH CLIP

(R2, R3 types)

EMERGENCY STOP SWITCH

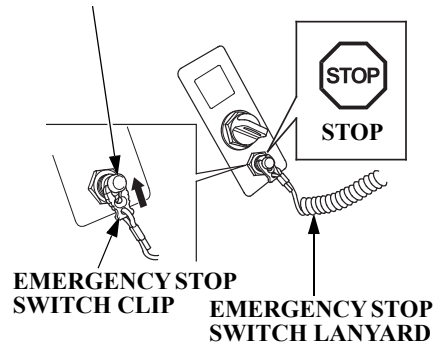

Spare Emergency Stop Switch Clip (optional equipment)

A spare emergency stop switch clip is available from your outboard motor dealer.

A spare emergency stop switch clip can be stored in the tool bag (see page 120).

CONTROLS AND FEATURES

Tilt Lock Lever

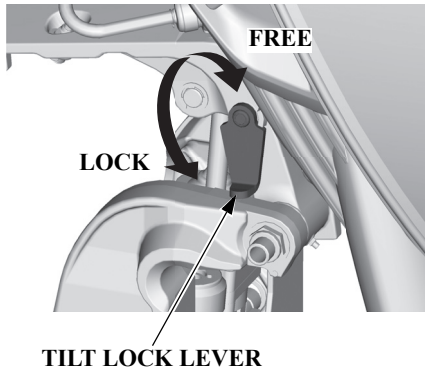

Use the tilt lock lever to raise the outboard motor and lock it in the position when the boat is moored or anchored for a long time.

Tilt the outboard motor as far as it goes and move the lock lever in the locking direction.

Trim Tab

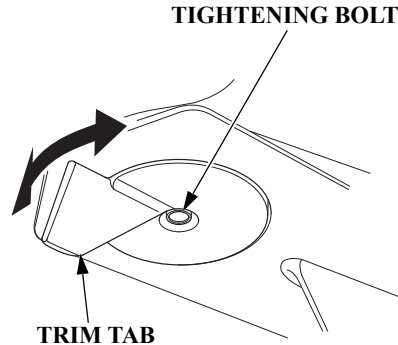

If the steering wheel is pulled to the side while running at full speed, adjust the trim tab so that the boat runs straight ahead.

Loosen the tightening bolt and turn the trim tab right or left to adjust (see page 104).

Anodes

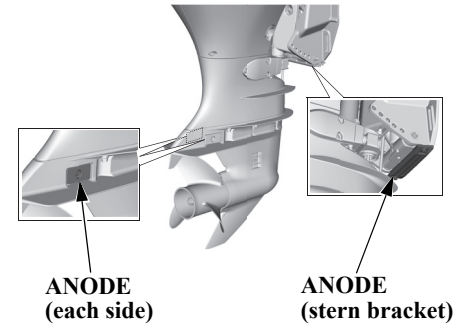

The anodes are a sacrificial material which helps to protect the outboard motor from corrosion.

NOTICE

Do not paint the anode. It deteriorates the function of the anode metal, which can lead to rust and corrosion damage to the outboard motor.

Cooling Water Check Hole

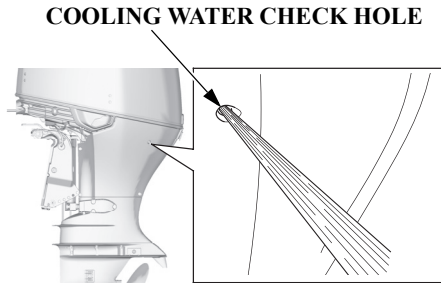

The cooling water is checked here to see whether it is circulating inside the engine properly.

After starting the engine, check at the cooling water check hole whether the cooling water is circulating through the engine.

Cooling Water Intake Port

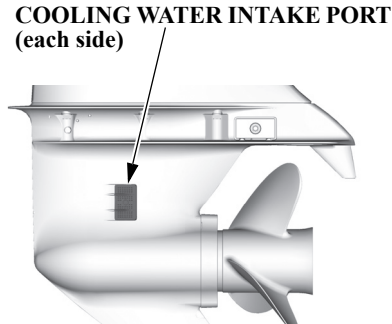

The engine cooling water is drawn into the engine through this port.

Engine Cover Latches

Front



Side

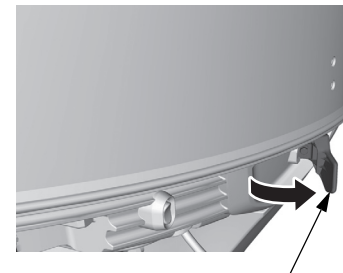

ENGINE COVER LATCH (each side)

Pull the engine cover latches to remove the engine cover.

CONTROLS AND FEATURES

Tachometer (optional equipment)

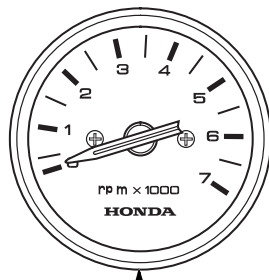

TACHOMETER

The tachometer shows the engine speed in revolutions per minute.

NMEA Interface Coupler

The NMEA2000 interface coupler can provide information regarding engine speed, fuel consumption, and various warnings to an existing NMEA2000 network via an optional interface cable. Contact your dealer for more information.

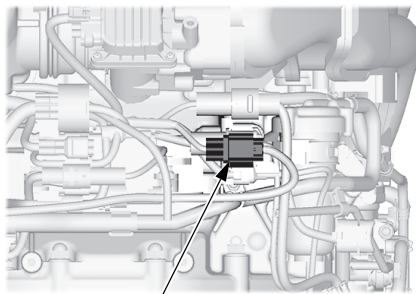

NMEA INTERFACE COUPLER

Operating Hour Notification System

This outboard motor engine counts the number of operating hours since the last periodic maintenance. When the next periodic maintenance is due, the engine notifies the NMEA2000 network, and a maintenance indication is displayed on an NMEA2000-compatible device.

After periodic maintenance is performed, reset the hour counter by:

DBW type:

1. Turning ON the power switch or ignition switch. (The buzzer will sound twice.)
 - Wait at least 1 second.
2. With the control lever of the outboard motor, shifting to the "F" (forward) or "R" (reverse) gear.
3. Turning OFF the power switch or ignition switch.
4. Turning ON the power switch or ignition switch. (The buzzer will sound twice.)
5. Inserting and removing the emergency stop switch clip five times within 20 seconds.
 - When reset, the buzzer will sound once.

Mechanical wire type:

1. Stopping the engine.
2. Setting the gearshift at F or R.
3. Turning the ignition switch ON.
The buzzer will sound once.
4. Pressing the emergency stop switch 5 times within 20 seconds.
When using the switch panel without indicators type, within 20 seconds, pull and insert the emergency stop switch clip, or remove the clip and pull the emergency stop switch 5 times.
The buzzer will sound once when the hour counter is reset.

Periodic maintenance is required when either the operating hours or the time since last maintenance reaches the prescribed limit. Therefore, periodic maintenance may be required based on the number of months since the last maintenance before the alert based on engine operating hours displays (see Maintenance Schedule on page 121). Reset the hour counter whenever maintenance is performed, whether based on the time interval or the number of operating hours.

<Operating hour notification timing>

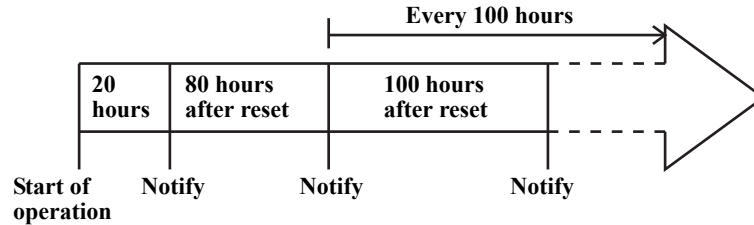

<Display>

Steps	1	2	3	4
Outboard motor	—	Ignition switch ON	Start engine	Gear at F or R
Display	Switch ON	—	—	—
Maintenance indication on display	Not shown Maintenance indication	Shown Maintenance indication	Shown Maintenance indication	Not shown Maintenance indication

CONTROLS AND FEATURES

NMEA2000-compatible display:

- Follow instructions for the display.
- If the display allows selection of notification to be preset, select “Notify” (or equivalent).
- Turn on the power supply to the display before turning on the ignition switch of the outboard motor.
- The indication may differ, depending on the type of display.

When “Periodic Maintenance” is indicated:

1. Have the periodic maintenance performed without delay after returning to port.
2. Reset the hour counter.
If not reset, the maintenance indication will remain in the display, and the hour count until the next maintenance will be in error.

When the periodic maintenance is conducted before “Periodic Maintenance” is indicated, reset the hour counter.

If not reset, the hour count until the next maintenance will be in error.

How to reset the Hour Counter

1. Be sure to turn OFF the engine before beginning the reset procedure. Pull the emergency stop switch clip out of the emergency stop switch by pulling the emergency stop switch lanyard.
2. Put the shift lever in “F” (Forward) or “R” (Reverse).
3. Turn the ignition switch ON. Do not start the engine. The buzzer will sound once.
4. Press the emergency stop switch 5 times within 20 seconds.
When using the switch panel without indicators type, within 20 seconds, pull and insert the emergency stop switch clip, or remove the clip and pull the emergency stop switch 5 times.

The buzzer will sound once indicating the hour counter is reset.

Battery Switch OFF Notification

This function alerts the operator that the battery switch is OFF and must be turned to the ON position. If the battery switch is OFF, a buzzer will sound three times during the following situations.

- When starting the engine
- When using the power trim/tilt switch
- When turning the battery switch OFF while the ignition switch or power switch is ON

5. INSTALLATION

NOTICE

Improperly installed outboard motor can result in the outboard motor dropped into the water, boat not able to cruise straight ahead, engine speed not increase, and much fuel consumption.

We recommend that the outboard motor be installed by an authorized Honda outboard motor dealer. Consult the authorized Honda dealer in your area for the Y-OP (User Optional Parts)/equipments installation and operation.

Applicable Boat
Select the boat suitable for the engine power.

Engine power:
BF115J: 84.6 kW (115 PS)
BF135D: 99.3 kW (135 PS)
BF150D: 110.3 kW (150 PS)

Power recommendation is indicated on most of the boats.

⚠ WARNING

Do not exceed the boat manufacturer’s power recommendation. Damage and injury may result.

Transom Height

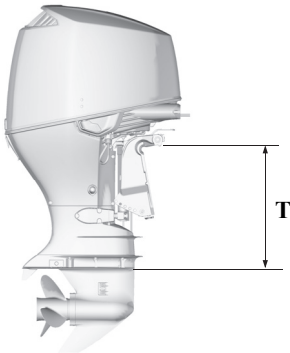

Type:	T (Outboard Motor Transom Height) <when transom angle is 12°>
L:	508 mm (20.0 in)
X:	635 mm (25.0 in)

Select the outboard motor which is correct for the boat transom height of your boat.

INSTALLATION

Location

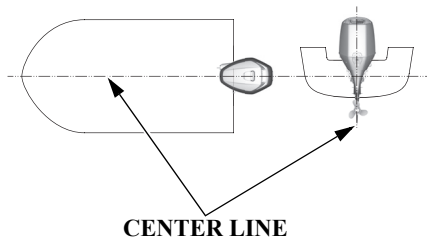

Install the outboard motor at the stern, at the center line of the boat.

Installation Height

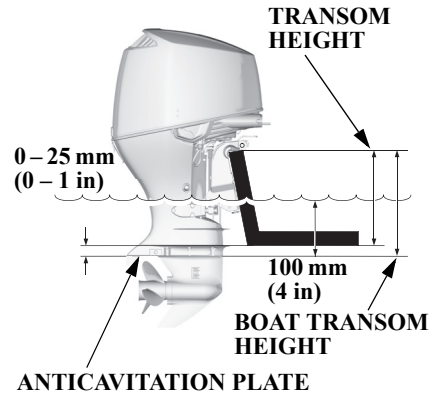

The anticavitation plate of the outboard motor should be 0 – 25 mm (0 – 1 in) below the bottom of the boat.

The correct dimensions differ according to the type of boat and the configuration of the bottom of the boat. Follow the manufacturer's recommended installation height.

NOTICE

- The water level must be at least 100 mm (4 in) above the anticavitation plate, otherwise the water pump may not receive sufficient cooling water, and the engine will overheat.

Outboard Motor Installation

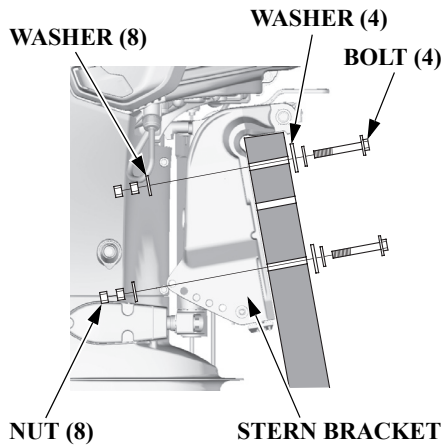

1. Apply the silicone sealant (Three Bond 1216 or equivalent) to the outboard motor mounting holes.
2. Set the outboard motor on the boat and secure with the bolts, washers, and lock nuts.

NOTE:

Standard torque:

55 N·m (5.6 kgf·m, 41 lbf·ft)

The standard torque is given just as a guideline. Torque of the nut can be different according to the material of the boat. Consult with an authorized Honda outboard motor dealer.

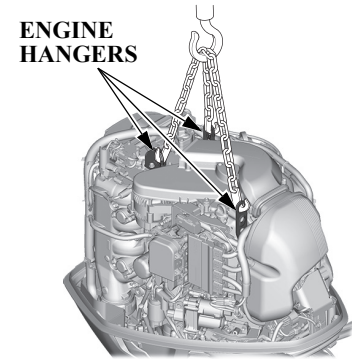

⚠ CAUTION

Install the outboard motor securely. Loosely mounted outboard motor can result in accidental loss of the outboard motor and damage and injury to the equipment and personnel.

Before installing the outboard motor on the boat, hang the outboard motor with the hoist or equivalent device by attaching the three engine hangers to the outboard motor.

Use the hoist which allowable load is 250 kg (551 lbs) or above.

INSTALLATION

Outboard Motor Angle Inspection (Cruising)

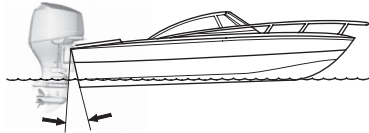

**INCORRECT
CAUSES BOAT TO “SQUAT”**

Install the outboard motor at the best trim angle for stable cruising and maximum power.
Trim angle too large: Incorrect causes boat to “squat.”

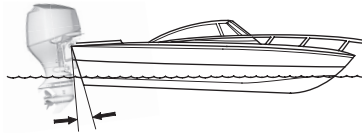

**INCORRECT
CAUSES BOAT TO “PLOW”**

Trim angle too small: Incorrect causes boat to “plow.”

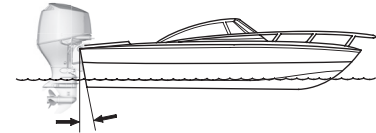

**CORRECT
GIVES MAXIMUM PERFORMANCE**

The trim angle differs according to the combination of the boat, outboard motor, and propeller, and the operating conditions.

Adjust the outboard motor so that it is perpendicular to the water surface (i.e. axis of the propeller is parallel with the water surface).

Battery Connections

Use a battery which has CCA 622A at -18°C (0°F) and a reserve capacity 229 minutes (12V-64Ah/5HR or 80Ah/20HR) or more specifications.

The battery is an optional part (i.e. part to be purchased separately from the outboard motor).

⚠ WARNING

Batteries produce explosive gases: If ignited, an explosion can cause serious injury or blindness. Provide adequate ventilation when charging.

- **CHEMICAL HAZARD:**

Battery electrolyte contains sulfuric acid. Contact with eyes or skin, even through clothing, may cause severe burns. Wear a faceshield and protective clothing.

- Keep flames and sparks away, and do not smoke in the area.
- ANTIDOTE: If electrolyte gets into your eyes, flush thoroughly with warm water for at least 15 minutes and call a physician immediately.

- **POISON:** Electrolyte is poison.
- ANTIDOTE:
- External: Flush thoroughly with water.
 - Internal: Drink large quantities of water or milk. Follow with milk of magnesia or vegetable oil, and call a physician immediately.
- **KEEP OUT OF REACH OF CHILDREN.**

To protect the battery from mechanical damage and to prevent the battery from falling or tipping over, the battery must be:

- Installed in the correct size corrosion-resistant battery box.
- Properly secured in the boat.
- Secured in a location free from direct sunlight and water spray.
- Secured away from the fuel tank to avoid potential sparks near the fuel tank.

INSTALLATION

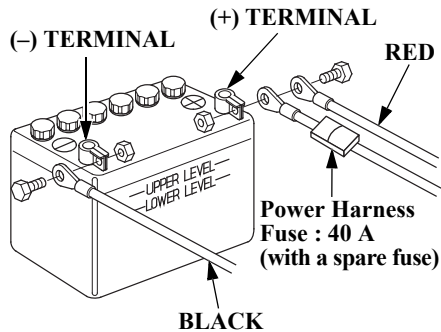

Connect the battery cables:

1. Connect the cable with the red terminal cover to the positive (+) terminal of the battery.
2. Connect the cable with the black terminal cover to the negative (-) terminal of the battery.

NOTE:

When more than one outboard motor is mounted on a boat, connect a battery to each respective outboard motors.

NOTICE

- Be sure to connect the (+) side battery cable first. When disconnecting the cables, disconnect the (-) side first then the (+) side.
- Unless the cables are properly connected to the terminals, the starter motor may fail to operate normally.
- Be careful to avoid connecting the battery in reverse polarity, as this will damage the battery-charging system in the outboard motor.
- Do not disconnect the battery cables while the engine is running. Disconnecting the cables while the engine is running, will damage the outboard motor's electrical system.
- Do not place the fuel tank near the battery.

- **Battery cable extension:**
Extending the original battery cable will cause the battery voltage to drop due to the increased length of the cable and number of connections. This voltage drop may cause the buzzer to sound momentarily when engaging the starter motor and may prevent the outboard from starting. If the outboard starts and the buzzer sounds momentarily, there may be barely sufficient voltage reaching the engine.

Battery posts, terminals, and related accessories contain lead and lead compounds.

Wash your hands after handling.

Remote Control Installation (optional equipment)

NOTICE

Improperly installed steering system, remote control box, and remote control cable, or installing those of the different types could cause unpredictable accident. Consult an authorized Honda outboard motor dealer for proper installation.

The control box is available in types as shown.

Select the most suitable control box for your outboard motor considering the installation position, operationability, etc. of the control box.

See an authorized Honda outboard motor dealer for further information.

INSTALLATION

DBW type:

REMOTE CONTROL BOX

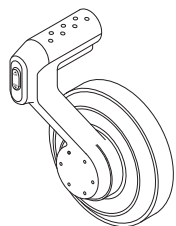

**FLUSH-MOUNT TYPE
CONTROL BOX**

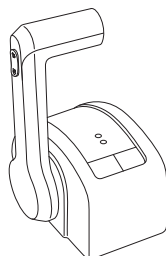

**TOP-MOUNT TYPE
CONTROL BOX
(FOR SINGLE
OUTBOARD
MOTOR TYPE)**

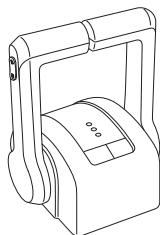

**TOP-MOUNT TYPE
CONTROL BOX
(FOR DUAL OUTBOARD
MOTOR TYPE)**

KEY SWITCH PANEL



**NORMAL KEY WITH
START/STOP SWITCH TYPE**



**NORMAL KEY WITHOUT
START/STOP SWITCH TYPE**

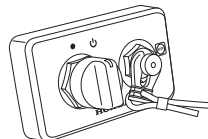

HONDA SMART KEY TYPE

START/STOP SWITCH PANEL

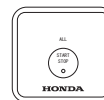

**ALL ENGINE START
FOR MULTIPLE
OUTBOARD MOTORS**

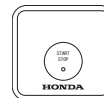

**SINGLE TYPE/
OUTBOARD MOTOR**

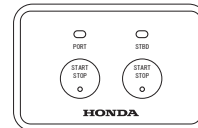

**DUAL TYPE
OUTBOARD MOTOR**

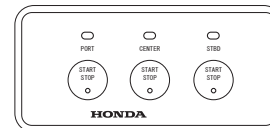

**TRIPLE TYPE
OUTBOARD MOTOR**

Mechanical wire type:

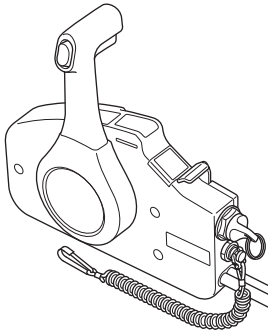

SIDE-MOUNT TYPE CONTROL BOX

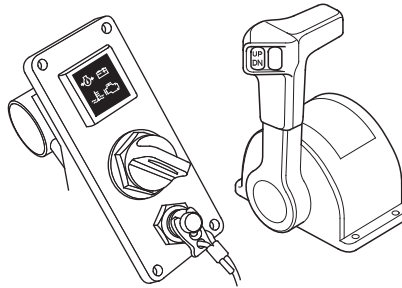

**TOP-MOUNT TYPE CONTROL BOX
AND SWITCH PANEL
(FOR SINGLE OUTBOARD MOTOR TYPE)**

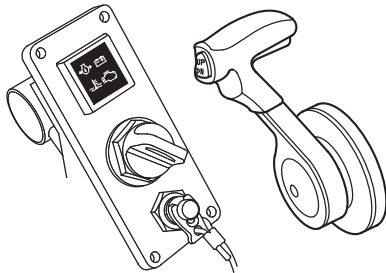

**FLUSH-MOUNT TYPE CONTROL BOX
AND SWITCH PANEL**

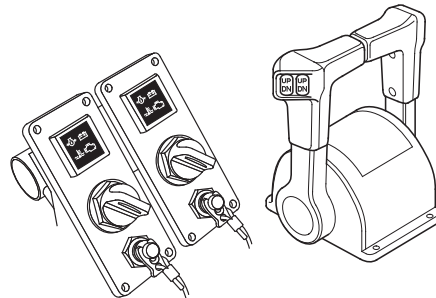

**TOP-MOUNT TYPE CONTROL BOX
AND SWITCH PANELS
(FOR DUAL OUTBOARD MOTOR TYPE)**

INSTALLATION

<Remote Control Box Location>

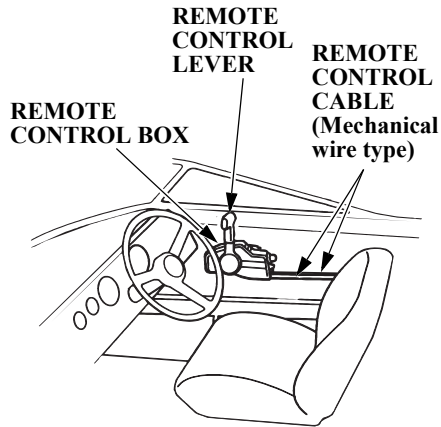

Install the remote control box in the position where is easy to operate the remote control lever and switches.

Mechanical wire type:

Be sure that there are no obstacles on the route of the control cable.

The control box position of the D1 type, D2 type, R2 type and the R3 type should be determined in the same manner.

<Remote Control Cable Length> (Mechanical wire type)

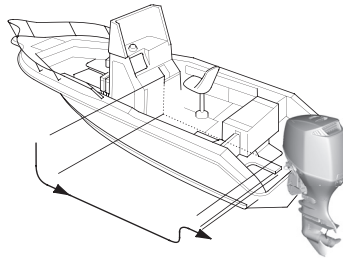

Measure the distance from the control box to the outboard motor along the cable routing.

Recommended cable length is 300 – 450 mm (11.8 – 17.7 in) longer than the measured distance.

Set the cable along the predetermined route and be sure that it is long enough to the route.

Connect the cable to the engine and be sure it is not kinked, bent sharp, pulled taut, or interfered while steering.

NOTICE

Do not bend the remote control cable as sharp as its route diameter is 300 mm (11.8 in) or less, or it affects the service life of the cable and the remote control lever operation.

Propeller Selection

Select the adequate propeller so that the engine speed at full throttle is BF115J: 4,500 min⁻¹ (rpm) to 6,000 min⁻¹ (rpm). BF135D/150D: 5,000 min⁻¹ (rpm) to 6,000 min⁻¹ (rpm) when the boat is loaded.

Engine speed varies according to the propeller size and the boat condition. Use of the outboard motor outside the full throttle speed range will adversely affect the engine and cause serious problem. Use of the correct propeller assures powerful acceleration, top speed, excellency in terms of economy and cruising comfort, and it assures longer engine life as well.

Consult with your authorized Honda outboard motor dealer for proper propeller selection.

Fuel Line Connection

Connect the fuel line to the tank and the outboard motor. Follow the boat manufacturer's instructions.

WARNING

Gasoline is extremely flammable, and gasoline vapor can explode, causing serious injury or death.

- Be careful not to spill fuel.
Spilled fuel or fuel vapor may ignite. If any fuel is spilled, make sure the area is dry before starting the engine.
- Keep heat, sparks, and flame away.

6. PRE-OPERATION CHECKS

BF115J/135D/150D is 4-stroke, water cooled outboard motor which uses unleaded regular gasoline for fuel. It also requires the engine oil. Check the following before operating the outboard motor.

⚠ CAUTION

Perform the following pre-operation checks with the engine stopped.

Before each use, look around and underneath the engine for signs of oil or gasoline leaks.

Engine Cover Removal/Installation



1. Pull all the engine cover latches.
2. Remove the engine cover by taking it up.

<Installation>

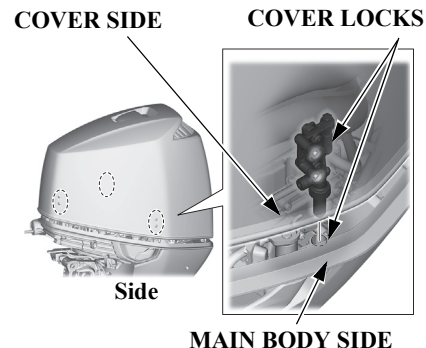

1. Place the engine cover on the main body.
2. Slide the engine cover so that the cover lock on the cover is mated with the lock in the main body.

PRE-OPERATION CHECKS

Front

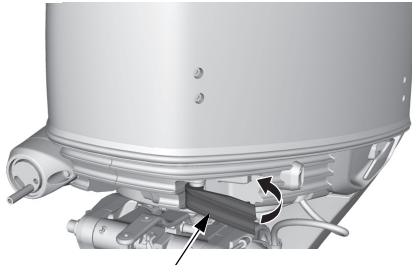

ENGINE COVER LATCH

Side

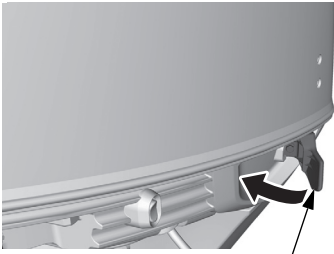

ENGINE COVER LATCH (each side)

3. Push the engine cover until any gap between the engine cover and main body is eliminated.
4. Push all the engine cover latches to lock them.

⚠ WARNING

Do not operate the outboard motor without the engine cover. Exposed moving parts can cause injury.

Engine Oil

NOTICE

- **Engine oil is a major factor affecting engine performance and service life. Nondetergent and low quality oils are not recommended, because they have inadequate lubricating properties.**
- **Running the engine with insufficient oil can cause serious engine damage.**

<Recommended oil>

Use Honda 4-stroke oil or an equivalent high detergent, premium quality motor oil certified to meet or exceed U.S. automobile manufacturer's requirements for API Service category SG, SH, SJ or SL. Motor oils classified SG, SH, SJ or SL will show this designation on the container.

PRE-OPERATION CHECKS

SAE 10W-30 is recommended for general use.

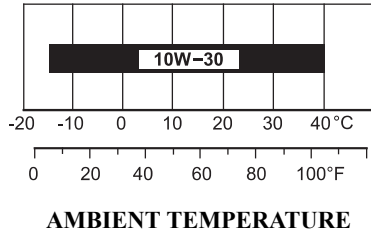

<Inspection and Refilling>

OIL LEVEL DIPSTICK

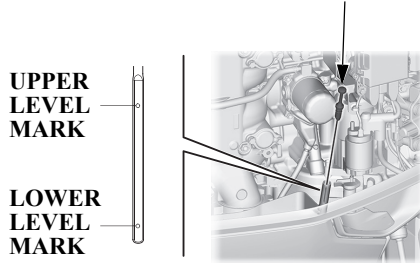

Check the engine oil level with the engine stopped and the outboard motor in the vertical position.

1. Unlock and remove the engine cover (see page 60).
2. Remove the oil level dipstick by pulling it. Wipe the oil level dipstick clean.
3. Insert the dipstick all the way in, then remove it and check the oil level shown on the dipstick.
4. If the oil level is near or below the lower level mark on the dipstick, remove the oil filler cap, and add oil to reach the upper level mark shown on the dipstick. Use the oil recommended on p. 61.
5. Insert the dipstick all the way in. Install the oil filler cap and tighten it securely. Do not overtighten.

OIL FILLER CAP

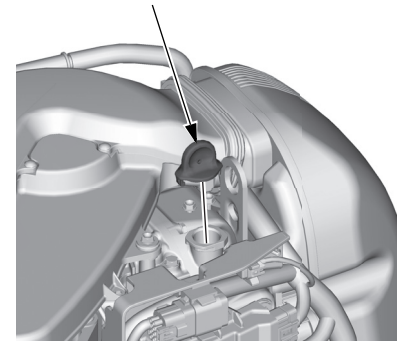

When the engine oil is contaminated or discolored, replace with the fresh engine oil (see page 123 for replacement interval and procedure).

6. Install the engine cover and lock it securely.

NOTICE

Do not overfill the engine oil. Check the engine oil after refilling. Excessive engine oil as well as the insufficient oil could cause damage to the engine.

PRE-OPERATION CHECKS

When you check the oil level with the dipstick, you might notice the engine oil appears milky or the oil level has increased. If you notice either condition, change the engine oil. See the following table for an explanation of these conditions.

Operating Method	Result	Effect
Running the engine below 3,000 min ⁻¹ (rpm) for more than 30% of the time so the engine does not warm up.	<ul style="list-style-type: none">• Water condenses in the engine and mixes with the oil, resulting in a milky appearance.• Unburned fuel mixes with the oil, increasing the volume of oil.	The engine oil deteriorates, becomes less efficient as a lubricant, and causes an engine malfunction.
Frequent starting and stopping without allowing the engine to warm up.		

Fuel

Check the fuel level and refill if necessary. Do not fill the fuel tank above the UPPER LIMIT.

Refer to the boat manufacturer's instructions.

Use unleaded gasoline with a Research Octane Number of 91 or higher (a Pump Octane Number of 86 or higher). Use of leaded gasoline may cause damage to the engine. Never use gasoline that is stale, contaminated, or mixed with oil. Avoid getting dirt, dust or water in the fuel tank.

PRE-OPERATION CHECKS

⚠ WARNING

Gasoline is extremely flammable and is explosive under certain conditions.

- Refuel in a well-ventilated area with the engine stopped.
- Do not smoke or allow flames or sparks in the area where the engine is refueled or where gasoline is stored.
- Do not overfill the fuel tank (there should be no fuel in the filler neck). After refueling, make sure the fuel filler cap is closed properly and securely.
- Be careful not to spill fuel when refueling. Spilled fuel or fuel vapor may ignite. If any fuel is spilled, make sure the area is dry before starting the engine.
- Avoid repeated or prolonged contact with skin or breathing of vapor.
- **KEEP OUT OF REACH OF CHILDREN.**

GASOLINE CONTAINING ALCOHOL

If you decide to use a gasoline containing alcohol (gasohol), be sure its octane rating is at least as high as that recommended by Honda. There are two types of “gasohol”: one containing ethanol, and the other containing methanol.

Do not use gasohol that contains more than 10% ethanol.

Do not use gasoline containing more than 5% methanol (methyl or wood alcohol) and that does not also contain co-solvents and corrosion inhibitors for methanol.

NOTE:

- Fuel system damage or engine performance problems resulting from the use of gasoline that contains more alcohol than recommended is not covered under the warranty.
- Before buying gasoline from an unfamiliar station, first determine if the gasoline contains alcohol, if it does, find out the type and percentage of alcohol used. If you notice any undesirable operating symptoms while using a particular gasoline. Switch to a gasoline that you know contains less than the recommended amount of alcohol.

Propeller and Cotter Pin Inspection

▲ WARNING

The propeller blades are thin and sharp. Careless handling of the propeller can result in injury.

When checking the propeller:

- Remove the emergency stop switch clip to prevent an accidental start of the engine.
- Wear heavy gloves.

Propeller rotates rapidly while cruising. Before starting the engine, check the propeller blades for damage and deformation and replace if necessary.

Obtain a spare propeller for the event of an unpredictable accident while cruising. If no spare propeller is available, return to the pier at low speed and replace (see page 140). Consult an authorized Honda outboard motor dealer for propeller selection.

Keep the spare washer, castle nut and cotter pin with you on your boat.

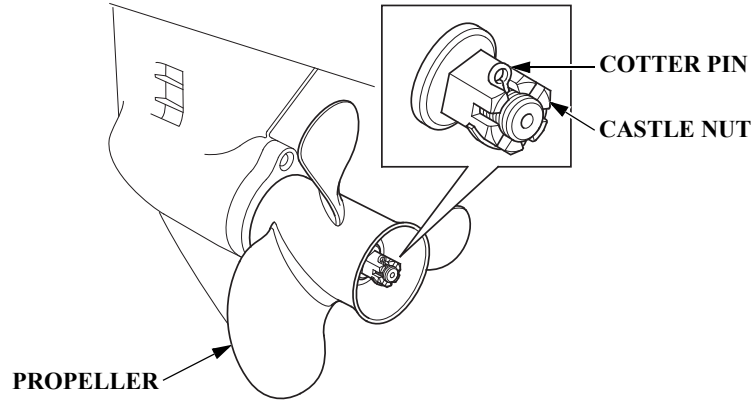

Engine speed varies according to the propeller size and the boat condition. Use of the outboard motor outside the full throttle speed range will adversely affect the engine and cause a serious problem. Use of the correct propeller assures powerful acceleration, top speed, excellency in terms of economy and cruising comfort, and it assures longer engine life as well.

Consult with your authorized Honda outboard motor dealer for proper propeller selection.

1. Check the propeller for damage, wear, or deformation. Replace whenever the propeller is faulty (see page 140).
2. Check whether the propeller is installed properly.
3. Check the cotter pin for damage.

PRE-OPERATION CHECKS

Remote Control Lever Friction (D1 type)

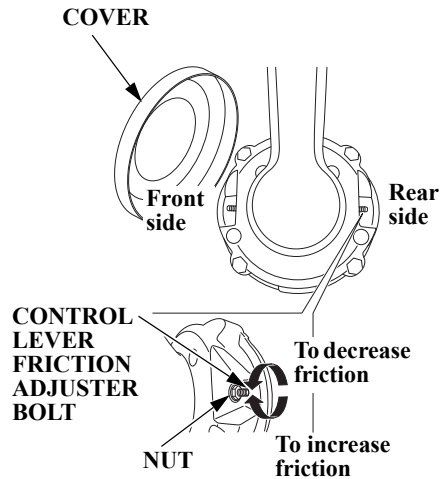

(D2 type)

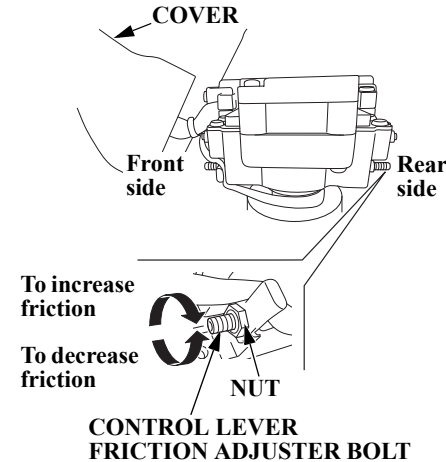

Check whether the remote control lever moves smoothly.

1. Remove the cover of the remote control lever.
2. Loosen the nut.
3. Adjust the lever friction when increasing throttle opening and boat speed by turning the control lever friction adjuster bolt right or left.
4. Tighten the nut to lock the lever friction.
5. Reinstall the cover of the remote control lever.

PRE-OPERATION CHECKS

(R1 type)

CONTROL LEVER FRICTION ADJUSTER

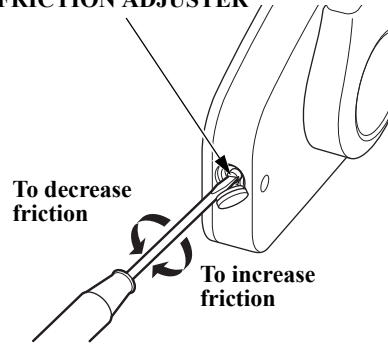

Check whether the remote control lever moves smoothly. Friction of the remote control lever can be adjusted by turning the control lever friction adjuster right or left.

(R2 type)

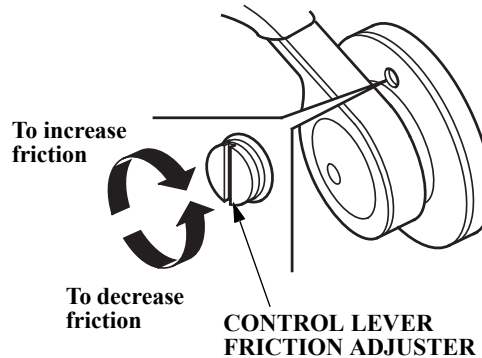

(R3 type)

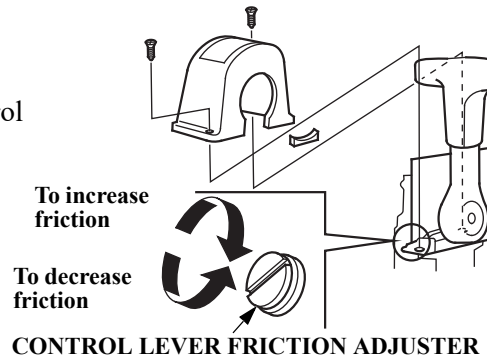

Fuel Filter with Water Separator

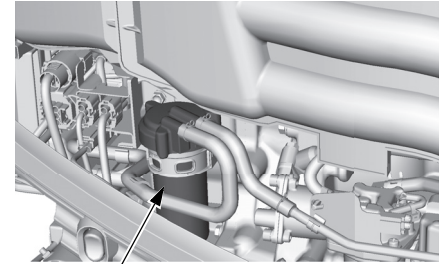

FUEL FILTER with WATER SEPARATOR

The fuel filter with water separator is located below the intake manifold. Check the fuel filter with water separator for water accumulation. If water is accumulated, drain them (see page 132).

PRE-OPERATION CHECKS

Battery

NOTICE

Battery handling differs according to the type of the battery and the instructions described below might not be applicable to the battery of your outboard. Refer to the battery manufacturer's instructions.

Battery Inspection

Check whether the battery fluid is between the upper and lower levels, and check the vent hole in the battery caps for clogging.

If the battery fluid is near or below the lower level, add the distilled water to the upper level (see page 135).

Check that the battery cables are connected securely. If the battery terminals are contaminated or corroded, remove the battery and clean the terminals (see page 136).

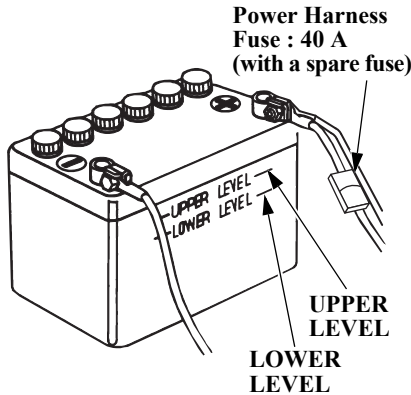

⚠ WARNING

Batteries produce explosive gases: If ignited, an explosion can cause serious injury or blindness. Provide adequate ventilation when charging.

- **CHEMICAL HAZARD:** Battery electrolyte contains sulfuric acid. Contact with eyes or skin, even through clothing, may cause severe burns. Wear a faceshield and protective clothing.

- Keep flames and sparks away, and do not smoke in the area. **ANTIDOTE:** If electrolyte gets into your eyes, flush thoroughly with warm water for at least 15 minutes and call a physician immediately.
- **POISON:** Electrolyte is poison. **ANTIDOTE:**
 - External: Flush thoroughly with water.
 - Internal: Drink large quantities of water or milk. Follow with milk of magnesia or vegetable oil, and call a physician immediately.
- **KEEP OUT OF REACH OF CHILDREN.**

Battery posts, terminals, and related accessories contain lead and lead compounds. Wash your hands after handling.

Other Checks

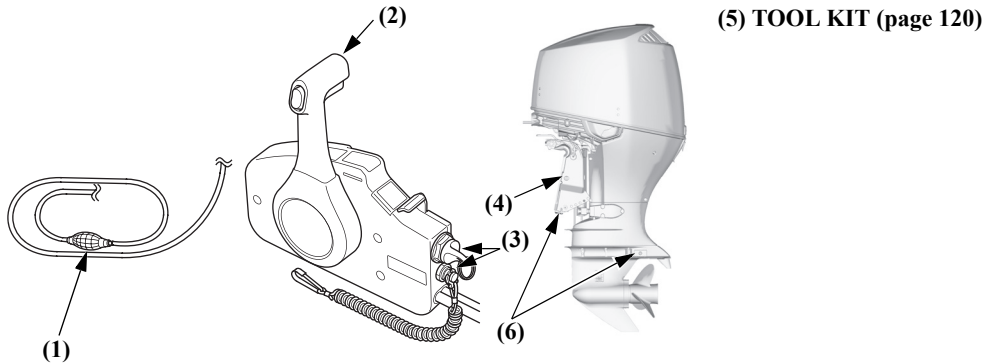

Check the following items:

- (1) The fuel hose for kinking, collapsing or a loose connection.
- (2) The remote control lever for smooth operation.
- (3) The switches for correct operation.
- (4) The stern bracket for damage.
- (5) The tool kit for missing spare parts and tools (page 120).
- (6) The anode metal for damage, looseness or excessive corrosion.

The anode (sacrificed metal) helps to protect the outboard motor from corrosion damage; it must be exposed directly to the water whenever the outboard motor is in use. Replace the anodes when they have been reduced to about two-thirds of their original size, or if they are crumbling.

NOTICE

The possibility of corrosion damage is increased if the anode is painted over or allowed to deteriorate.

Parts/materials which should be installed on board:

- Owner's Manual
- Tool kit
- Spare parts: spark plugs, engine oil, spare propeller, castle nut, washer and cotter pin.
- Spare emergency stop switch clip.
- Other parts/materials required by laws/regulations.

7. STARTING THE ENGINE

NOTICE

- Make sure the battery switch is **ON** before turning **ON** the ignition switch or power switch. If the battery switch is **OFF** while attempting to start the engine, the buzzer will sound three times.

Fuel Priming

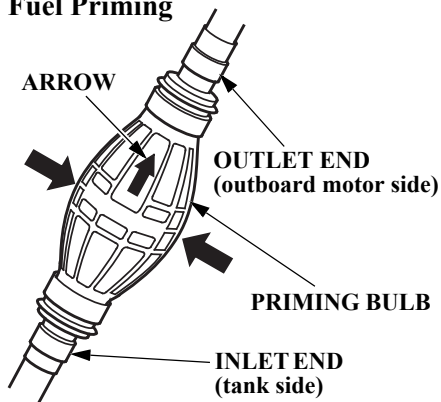

Hold the priming bulb so that the outlet end is higher than the inlet (so that the arrow on the priming bulb points up), and squeeze it until it feels firm, indicating that fuel has reached the outboard motor. Check for leaks.

⚠ WARNING

Be careful not to spill any fuel. Spilled fuel vapor may ignite. If any fuel is spilled, make sure the area is dry before starting the engine.

NOTICE

Do not touch the priming bulb with the engine running or when tilting up the outboard motor. The vapor separator could overflow.

Starting the Engine (D1, D2 types)

EMERGENCY STOP SWITCH

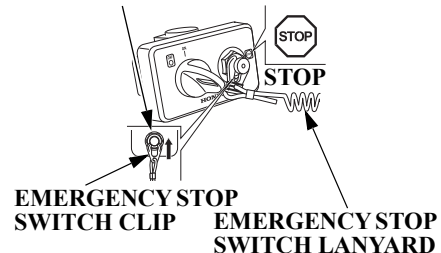

⚠ WARNING

Exhaust contains poisonous carbon monoxide which can cause unconsciousness and may lead to death. Never run the outboard motor in a boat house or other confined area.

NOTICE

To prevent damage to the outboard from overheating, never run the engine with the propeller out of water.

NOTE:

When the boat is mounted with the two outboard motors, perform the following on the right and left engines respectively.

1. Insert the emergency stop switch clip at one end of the emergency stop switch lanyard into the emergency stop switch. Attach the other end of the lanyard securely to the operator.

⚠ WARNING

If the operator does not attach the emergency stop switch lanyard, and is thrown from the seat or out of the boat, the out-of-control boat can seriously injure the operator, passengers, or bystanders. Always properly attach the lanyard before starting the engine.

**EMERGENCY STOP
SWITCH CLIP**

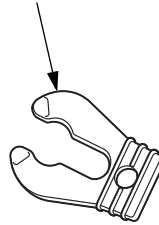

NOTE:

The engine does not start unless the emergency stop switch clip is set on the emergency stop switch.

A spare emergency stop switch clip can be stored in the tool bag (see page 120).

STARTING THE ENGINE

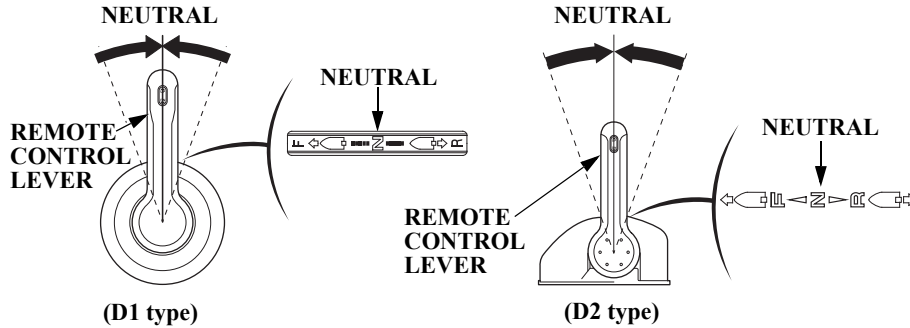

2. Set the control lever in the NEUTRAL position.
The engine does not start unless the control lever is set in the NEUTRAL position.

(Normal Key without START/STOP switch type)

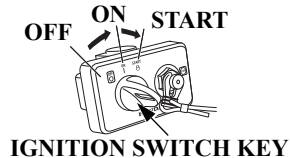

3. Turn the ignition switch key to the START position until the engine starts.
When the engine starts, release the key, allowing it to return to the ON position.
Go to step 5.

NOTICE

- Do not turn the ignition switch key to the START position while the engine is running.

(Normal Key with START/STOP switch type)

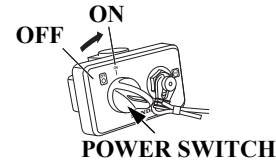

3. Insert the key to the power switch and turn it to the ON position.
4. Push the start/stop switch.

START/STOP SWITCH

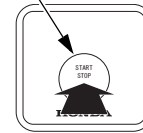

(Honda Smart Key type)

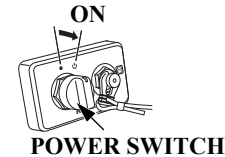

3. Turn the power switch to the right.

STARTING THE ENGINE

NOTE:

The power will not be turned ON unless the Honda Smart Key is authenticated.

4. Push the start/stop switch.

NOTE:

When the boat is mounted with the two outboard motors, push the all engine start switch.

NOTICE

- **The starter motor consumes a large amount of current. Do not therefore run it continuously for more than 5 seconds at a time. If the engine does not start within 5 seconds, wait at least 10 seconds before running the starter motor again.**

COOLING WATER CHECK HOLE



COOLING WATER INTAKE PORT (each side)

5. After starting, check whether the cooling water is flowing out of the cooling water check hole. Amount of water flowing out of the check hole might vary due to the thermostat operation, but this is normal.

NOTICE

If water does not flow out, or if steam comes out, stop the engine. Check to see if the screen in the cooling water intake port is obstructed and remove foreign materials if necessary. Check the cooling water check hole for clogging. If water still does not flow out, have your outboard motor checked by an authorized outboard motor dealer. Do not operate the engine until the problem has been corrected.

STARTING THE ENGINE

ENGINE OIL PRESSURE INDICATOR

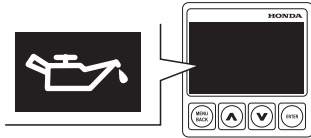

NORMAL: OFF
ABNORMAL: ON

6. Check to see if the oil pressure indicator turns ON.

If it does not turn on, stop the engine and perform the following inspections.

- 1) Check the oil level (see page 62).
- 2) If the oil level is normal and the oil pressure indicator does not turn ON, consult with an authorized Honda outboard motor dealer.

7. Warm up the engine as follows:
Above 5°C (41°F) – run the engine for 2 or 3 minutes.
Below 5°C (41°F) – run the engine for at least 5 minutes at 2,000 min⁻¹ (rpm).
Failure to completely warm up the engine will result in poor engine performance.

NOTICE

If the engine is not properly warmed-up before raising the engine speed, the warning buzzer and overheat indicator may activate and the engine speed will be automatically reduced.

NOTE:

Before leaving the dock, check the operation of the emergency stop switch.

STARTING THE ENGINE

(R1 type)

EMERGENCY STOP SWITCH

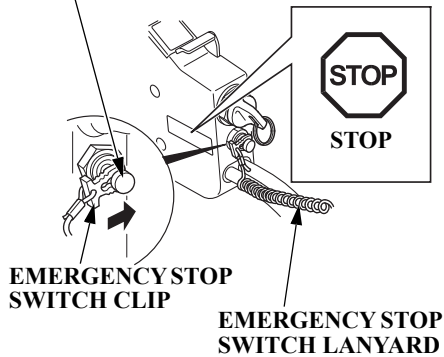

⚠ WARNING

Exhaust contains poisonous carbon monoxide which can cause unconsciousness and may lead to death. Never run the outboard motor in a boat house or other confined area.

NOTICE

To prevent damage to the outboard from overheating, never run the engine with the propeller out of water.

1. Insert the emergency stop switch clip at one end of the emergency stop switch lanyard into the emergency stop switch. Attach the other end of the emergency stop switch lanyard securely to the operator.

⚠ WARNING

If the operator does not attach the emergency stop switch lanyard, and is thrown from the seat or out of the boat, the out-of-control boat can seriously injure the operator, passengers, or bystanders. Always properly attach the lanyard before starting the engine.

NOTE:

The engine will not start unless the emergency stop switch clip is engaged with the emergency stop switch.

SPARE EMERGENCY STOP SWITCH CLIP (optional equipment)

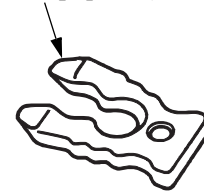

A spare emergency stop switch clip (optional equipment) can be stored in the tool bag (see page 120).

STARTING THE ENGINE

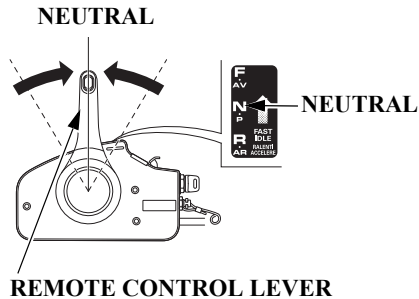

2. Set the remote control lever in the NEUTRAL position.
The engine does not start unless the remote control lever is set in the NEUTRAL position.
3. Leave the fast idle lever in the OFF (fully lowered) position.

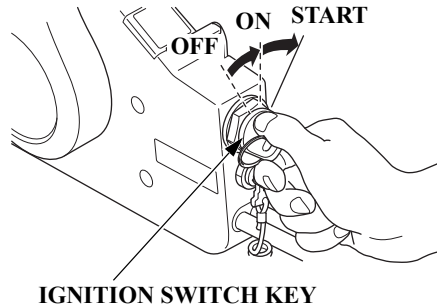

4. Turn the ignition switch key to the START position until the engine starts.
When the engine starts, release the key, allowing it to return to the ON position.

NOTICE

- The starter motor consumes a large amount of current. Do not therefore run it continuously for more than 5 seconds at a time. If the engine does not start within 5 seconds, wait at least 10 seconds before running the starter motor again.
- Do not turn the ignition switch key to the START position while the engine is running.

NOTE:

The “Neutral Starting System” prevents the engine from being started unless the control lever is set in the N (neutral) position even though the engine is cranked by the starting engine.

STARTING THE ENGINE

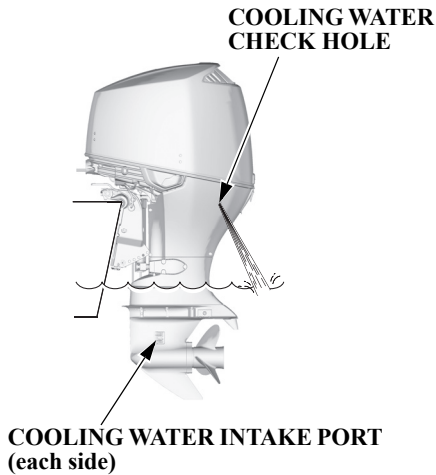

5. After starting, check whether the cooling water is flowing out of the cooling water check hole. Amount of water flowing out of the check hole might vary due to the thermostat operation, but this is normal.

NOTICE

If water does not flow out, or if steam comes out, stop the engine. Check to see if the screen in the cooling water intake port is obstructed and remove foreign materials if necessary. Check the cooling water check hole for clogging. If water still does not flow out, have your outboard motor checked by an authorized Honda outboard motor dealer. Do not operate the engine until the problem has been corrected.

6. Check to see if the oil pressure indicator turns ON.

If it does not turn on, stop the engine and perform the following inspections.

- 1) Check the oil level (see page 61).
- 2) If the oil level is normal and the oil pressure indicator light does not turn ON, consult with an authorized Honda outboard motor dealer.

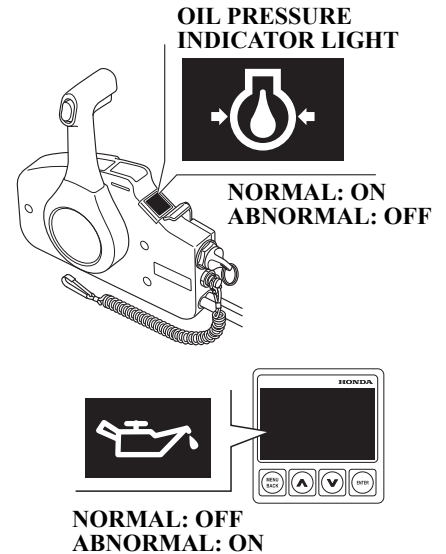

7. Warm up the engine as follows:
Above 5°C (41°F) – run the engine for at least 3 minutes.
Below 5°C (41°F) – run the engine for at least 5 minutes at approx. 2,000 min⁻¹ (rpm).
Failure to completely warm up the engine will result in poor engine performance.

STARTING THE ENGINE

NOTICE

- If the engine is not properly warmed-up before raising the engine speed, the warning buzzer and overheat indicator may activate and the engine speed will be automatically reduced.
- The cooling system may freeze in areas where the temperature reaches 0°C (32°F) or below. Cruising at high speed without warming the engine up may cause engine damage.

NOTE:

Before leaving the dock, check the operation of the emergency stop switch.

(R2, R3 types)

⚠ WARNING

Exhaust contains poisonous carbon monoxide which can cause unconsciousness and may lead to death. Never run the outboard motor in a boat house or other confined area.

NOTICE

To prevent damage to the outboard from overheating, never run the engine with the propeller out of water.

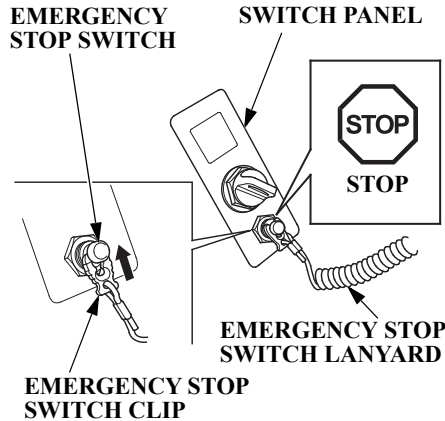

NOTE:

When the boat is mounted with the two outboard motors, perform the following on the right and left engines respectively.

1. Insert the clip at one end of the emergency stop switch lanyard into the emergency stop switch. Attach the other end of the emergency stop switch lanyard securely to the operator.

Be sure to install the emergency stop switch clip to the emergency stop switch on the remote control box as well as on the switch panel.

⚠ WARNING

If the operator does not attach the emergency stop switch lanyard, and is thrown from the seat or out of the boat, the out-of-control boat can seriously injure the operator, passengers, or bystanders. Always properly attach the lanyard before starting the engine.

STARTING THE ENGINE

NOTE:

The engine does not start unless the emergency stop switch clip is set on the emergency stop switch.

SPARE EMERGENCY STOP SWITCH CLIP (optional equipment)

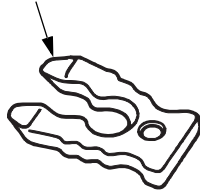

A spare emergency stop switch clip (optional equipment) can be stored in the tool bag (see page 120).

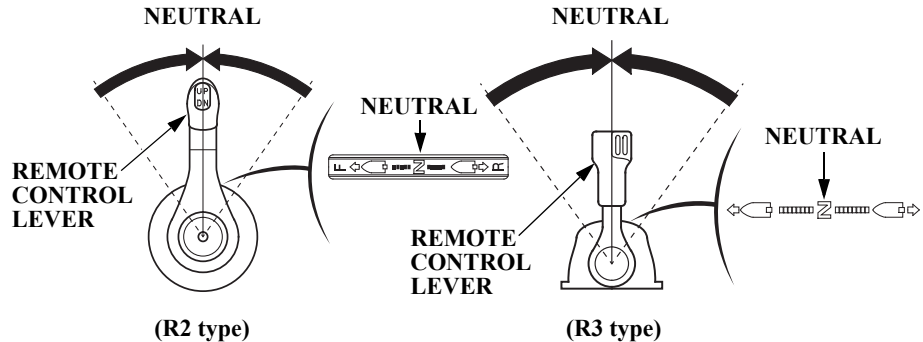

2. Set the remote control lever in the NEUTRAL position.
The engine does not start unless the remote control lever is set in the NEUTRAL position.

STARTING THE ENGINE

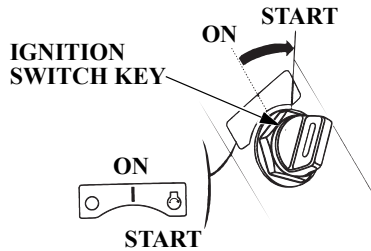

3. Turn the ignition switch key to the START position until the engine starts.

When the engine starts, release the key, allowing it to return to the ON position.

NOTICE

- **The starter motor consumes a large amount of current. Do not therefore run it continuously for more than 5 seconds at a time. If the engine does not start within 5 seconds, wait at least 10 seconds before running the starter motor again.**
- **Do not turn the ignition switch key to the START position while the engine is running.**

NOTE:

- When the boat is mounted with the two outboard motors, perform the above procedure on the right and left outboard motors respectively.
- The “Neutral Starting System” prevents the engine from being started unless the control lever is set in the N (neutral) position even though the engine is cranked by the starting engine.

COOLING WATER CHECK HOLE

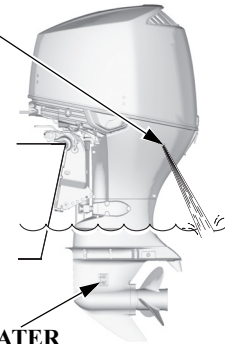

COOLING WATER INTAKE PORT (each side)

4. After starting, check whether the cooling water is flowing out of the cooling water check hole. Amount of water flowing out of the check hole might vary due to the thermostat operation, but this is normal.

STARTING THE ENGINE

NOTICE

If water does not flow out, or if steam comes out, stop the engine. Check to see if the screen in the cooling water intake port is obstructed and remove foreign materials if necessary. Check the cooling water check hole for clogging. If water still does not flow out, have your outboard motor checked by an authorized Honda outboard motor dealer. Do not operate the engine until the problem has been corrected.

ENGINE OIL PRESSURE INDICATOR

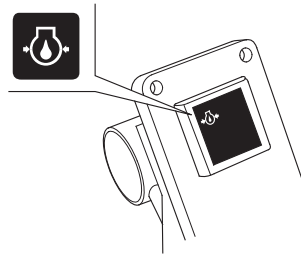

NORMAL: ON
ABNORMAL: OFF



NORMAL: OFF
ABNORMAL: ON

5. Check to see if the oil pressure indicator turns ON.

If it does not turn on, stop the engine and perform the following inspections.

- 1) Check the oil level (see page 61).
- 2) If the oil level is normal and the oil pressure indicator light does not turn ON, consult with an authorized Honda outboard motor dealer.

If using a flush-mount or top-mount switch panel without indicators, check the indicators displayed on an NMEA2000-compatible device.

6. Warm up the engine as follows:
Above 5°C (41°F) – run the engine for at least 3 minutes.
Below 5°C (41°F) – run the engine for at least 5 minutes at approx. 2,000 min⁻¹ (rpm).
Failure to completely warm up the engine will result in poor engine performance.

STARTING THE ENGINE

NOTICE

- If the engine is not properly warmed-up before raising the engine speed, the warning buzzer and overheat indicator may activate and the engine speed will be automatically reduced.
- The cooling system may freeze in areas where the temperature reaches 0°C (32°F) or below. Cruising at high speed without warming the engine up may cause engine damage.

NOTE:

Before leaving the dock, check the operation of the emergency stop switch.

Station Select Mode

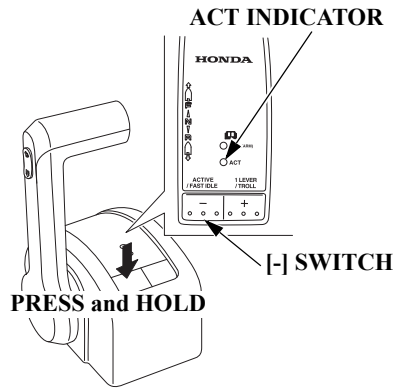

For multiple station type, use the [-] switch to change the operating station.

If you press and hold the [-] switch of the inactive station when all remote control lever is in the NEUTRAL position, you can operate the outboard motors using this station. A long buzz sounds once and the ACT indicator comes on when the station can be operated.

Break-in Procedure

Break-in period: 10 hours

Break-in operation allows the mating surfaces of the moving parts to wear evenly and thus ensures proper performance and longer outboard motor life.

Break-in your new outboard motor as follows.

First 15 minutes:

Run the outboard motor at trolling speed. Use the minimum amount of throttle opening necessary to operate the boat at a safe trolling speed.

Next 45 minutes:

Run the outboard motor up to a maximum of 2,000 to 3,000 min^{-1} (rpm) or 10% to 30% throttle opening.

Next 60 minutes:

Run the outboard motor up to maximum of 4,000 to 5,000 min^{-1} (rpm) or 50% to 80% throttle opening. Short bursts of full throttle are acceptable but do not operate the outboard motor continuously at full throttle.

Next 8 hours:

Avoid continuous full throttle operation (100% throttle opening). Do not run the outboard motor at full throttle for more than 5 minutes at a time.

For boats that plane easily, bring the boat up on plane then reduce the throttle opening to the specified break-in settings called out above.

OPERATION

Gear Shifting (D1 type)

REMOTE CONTROL LEVER

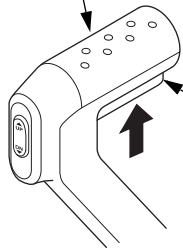

NEUTRAL RELEASE LEVER

FORWARD NEUTRAL REVERSE

REMOTE CONTROL LEVER

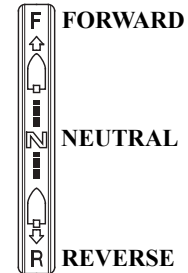
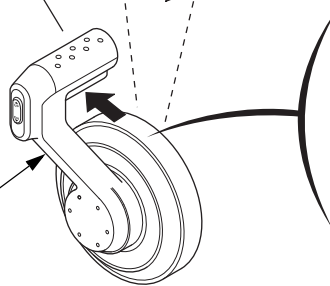

⚠ CAUTION

Avoid sharp and abrupt operation of the control lever. Operate it moderately. Operate the control lever and raise the engine speed after making sure that the gear was shifted securely.

While pulling the neutral release lever, move the control lever approximately 20° toward the FORWARD or REVERSE position to engage the desired gear.

Moving the control lever further from approximately 20° will increase throttle opening and boat speed.

The control lever will not move unless the neutral release lever is pulled up.

Gear Shifting (D2 type)

SINGLE TYPE

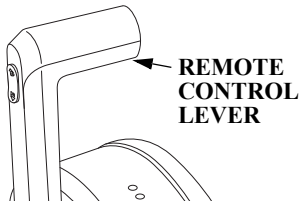

DUAL TYPE

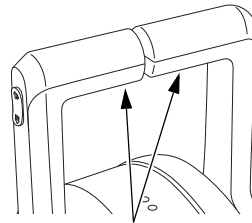

REMOTE CONTROL LEVERS

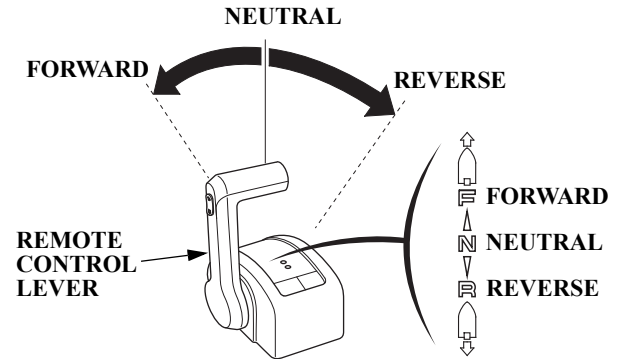

⚠ CAUTION

Avoid sharp and abrupt operation of the control lever. Operate it moderately. Operate the control lever and raise the engine speed after making sure that the gear was shifted securely.

Move the control lever(s) approximately 20° toward the FORWARD or REVERSE position to engage the desired gear.

When the boat is mounted with the two outboard motors, hold the control lever in the center as shown, and operate the right and left levers simultaneously.

Moving the control lever(s) further from approximately 20° will increase throttle opening and boat speed.

OPERATION

Gear Shifting (R1 type)

REMOTE CONTROL
LEVER

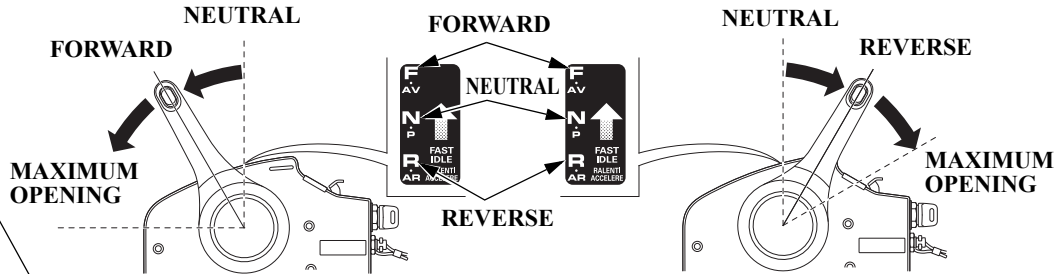
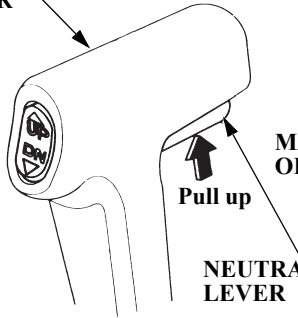

⚠ CAUTION

Avoid sharp and abrupt operation of the remote control lever. Operate it moderately. Operate the remote control lever and raise the engine speed after making sure that the gear was shifted securely.

While pulling the neutral release lever, move the remote control lever approximately 32° toward the FORWARD or REVERSE position to engage the desired gear.

Moving the remote control lever further from approximately 32° will increase throttle opening and boat speed.

The remote control lever will not move unless the neutral release lever is pulled up.

Gear Shifting (R2 type)

REMOTE CONTROL LEVER

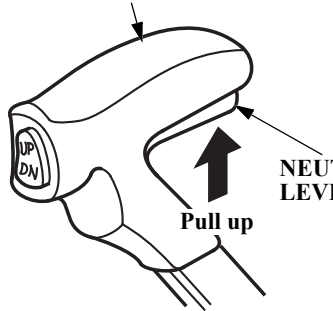

NEUTRAL RELEASE LEVER

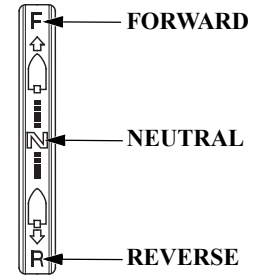
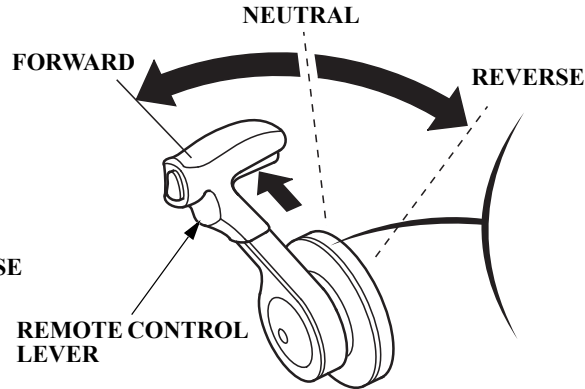

CAUTION

Avoid sharp and abrupt operation of the remote control lever. Operate it moderately. Operate the remote control lever and raise the engine speed after making sure that the gear was shifted securely.

While pulling the neutral release lever, move the remote control lever

approximately 35° toward the FORWARD or REVERSE position to engage the desired gear. Moving the remote control lever further from approximately 35° will increase throttle opening and boat speed.

The remote control lever will not move unless the neutral release lever is pulled up.

OPERATION

Gear Shifting (R3 type) SINGLE TYPE

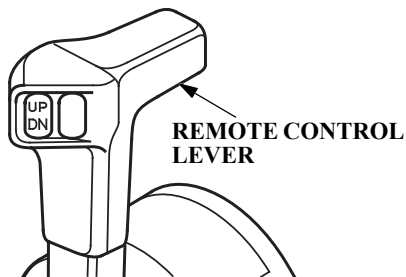

DUAL TYPE

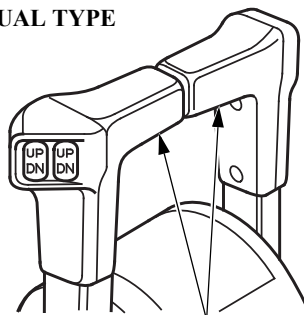

REMOTE CONTROL LEVERS

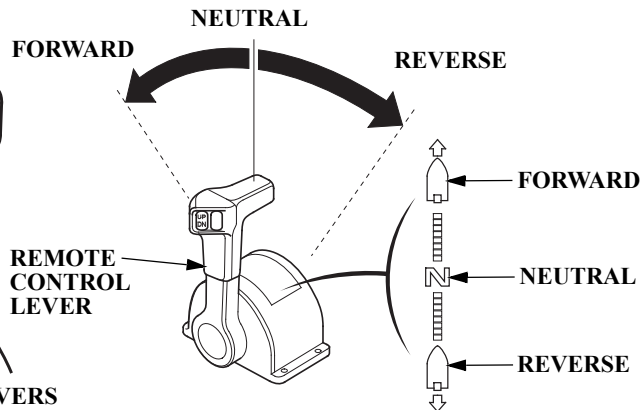

⚠ CAUTION

Avoid sharp and abrupt operation of the remote control lever. Operate it moderately. Operate the remote control lever and raise the engine speed after making sure that the gear was shifted securely.

Move the remote control lever(s) approximately 35° toward the FORWARD or REVERSE position to engage the desired gear.

When the boat is mounted with the two outboard motors, hold the remote control lever in the center as shown, and operate the right and left levers simultaneously.

Moving the remote control lever(s) further from approximately 35° will increase throttle opening and boat speed.

Cruising

POWER TRIM/TILT SWITCH

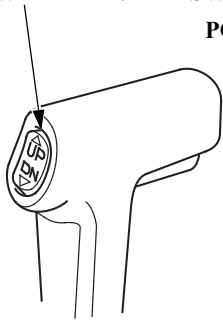

POWER TRIM/TILT SWITCH

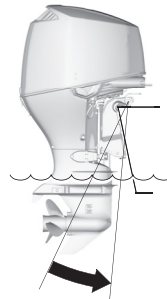
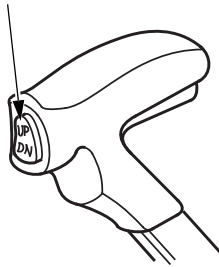

LOWERMOST POSITION

SINGLE TYPE

POWER TRIM/TILT SWITCH

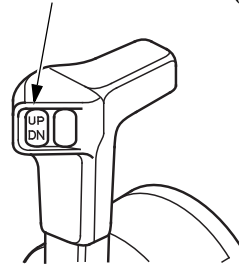

DUAL TYPE

POWER TRIM/TILT SWITCH (LEFT) (RIGHT)

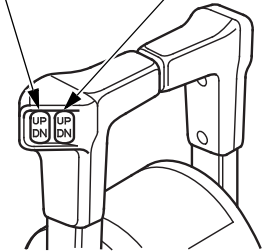

SINGLE TYPE

POWER TRIM/TILT SWITCH

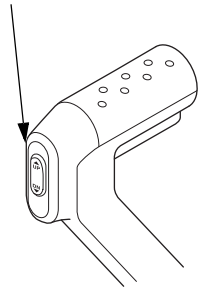

DUAL TYPE

POWER TRIM/TILT SWITCH

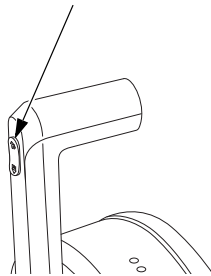

DUAL TYPE

POWER TRIM/TILT SWITCH

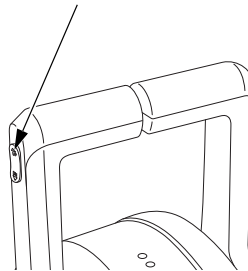

PANEL TYPE

POWER TRIM/TILT SWITCH

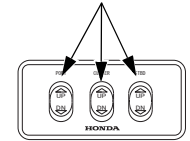
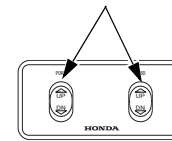

OPERATION

1. Press on the DN (down) of the power trim/tilt switch and trim the outboard motor at the lowermost position.

D2 type:

When the two or more outboard motors are mounted:

- 1) Press on the DN (down) of the power trim/tilt switch on the remote control lever and trim the outboard motors at the lowermost position.
- 2) With the outboard motors trimmed at the lowermost position, adjust the trim angle of the each outboard motor using the switch on the panel.

R3 type:

When the two outboard motors are mounted:

- 1) Press on the DN (down) of the power trim/tilt switch on the remote control lever and trim the outboard motors at the lowermost position.

- 2) With the outboard motors trimmed at the lowermost position, adjust the trim angle of the right and left outboard motors using the switch on the remote control lever simultaneously.

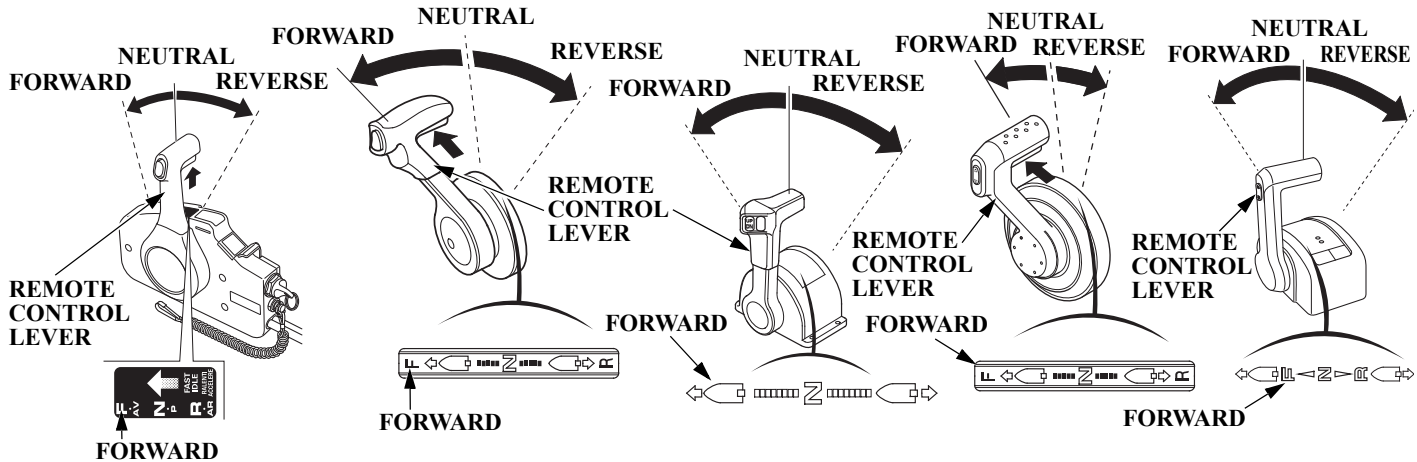

2. Move the control lever from NEUTRAL toward FORWARD position.

D1, D2 types:
Moving about 20° engages the gear. Moving the control lever further opens the throttle and increase the boat speed.

R1 type:
Moving about 32° engages the gear. Moving the control lever further opens the throttle and increases the engine speed.

R2, R3 types:
Moving about 35° engages the gear. Moving the control lever further opens the throttle and increase the boat speed.

For the sake of fuel economy, open the throttle about 80%.

OPERATION

NOTE:

- When cruising at full throttle, note that the engine speed must be in the range BF115J: between 4,500 min^{-1} (rpm) and 6,000 min^{-1} (rpm), BF135D/150D: between 5,000 min^{-1} (rpm) and 6,000 min^{-1} (rpm).
- If you feel that the engine speed jumped up when the hull jumped or at ventilation, cruise the boat by returning the throttle to the slow speed side.
- See “Propeller Selection” (see page 59) for a relation between the propeller and the engine speed.

⚠ CAUTION

Do not operate without the engine cover. Exposed moving parts could cause injury; water may damage the engine.

NOTE:

For best performance, passengers and equipment should be distributed evenly to balance the boat.

TRL (Trolling) Control Switch (Mechanical wire type)

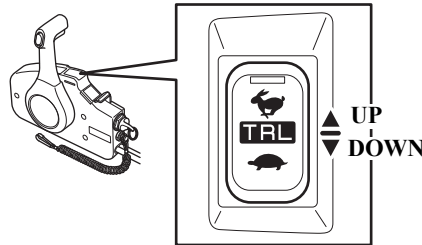

TRL (Trolling)
CONTROL SWITCH

Remote Control Box (Side-mount type)

For TRL (Trolling) control switch equipped type.

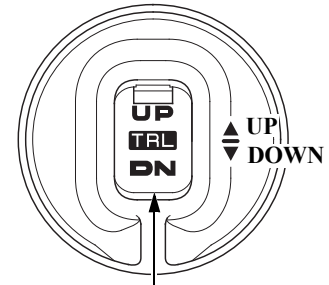

TRL (Trolling) CONTROL SWITCH

TRL (Trolling) Control Switch Panel (optional equipment)

UP: Increase engine speed
DN: Reduce engine speed

After the engine has warmed up, keeping the UP or DN button pushed when cruising with the throttle fully closed, changes the mode to trolling mode.

A long buzz sounds once.

When the mode is changed to trolling mode, the engine speed is 650 min^{-1} (rpm).

You can adjust the engine speed by 50 min^{-1} (rpm) every time you press the switch once. You will hear a short buzz.

The engine speed can be adjusted within the range of $650 - 900 \text{ min}^{-1}$ (rpm).

Continuing to press the switch will not decrease or increase the engine speed beyond the lower (650 min^{-1} (rpm)) or higher (900 min^{-1} (rpm)) limit.

If you try to do this, a short buzz sounds twice.

The throttle may be operated while in trolling mode. The trolling mode is cancelled when you reach $3,000 \text{ min}^{-1}$ (rpm).

Trolling Mode (DBW type)

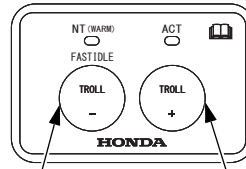

[-] SWITCH

[+] SWITCH

(ELECTRICAL REMOTE CONTROL
BOX and FLUSH-MOUNT type)

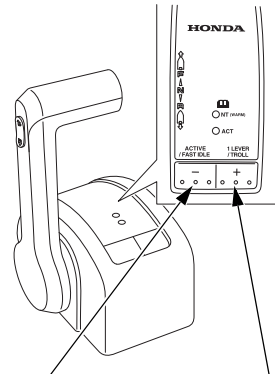

[-] SWITCH

[+] SWITCH

(ELECTRICAL REMOTE CONTROL
BOX and TOP-MOUNT type)

[-] Switch: Reduce engine speed
[+] Switch: Increase engine speed

After the engine has warmed up, keeping [+] switch pushed when cruising with the throttle fully closed, changes the mode to trolling mode.

OPERATION

A long buzz sounds once.

When the mode is changed to trolling mode, the engine speed is 650 min^{-1} (rpm).

You can adjust the engine speed by 50 min^{-1} (rpm) every time you press the switch once. You will hear a short buzz.

The engine speed can be adjusted within the range of $650 - 900 \text{ min}^{-1}$ (rpm).

Continuing to press the switch will not decrease or increase the engine speed beyond the lower (650 min^{-1} (rpm)) or higher (900 min^{-1} (rpm)) limit.

If you try to do this, a short buzz sounds twice.

The throttle may be operated while in trolling mode. The trolling mode is cancelled when you reach $3,000 \text{ min}^{-1}$ (rpm).

One-Lever Mode (For multiple outboard motors type)

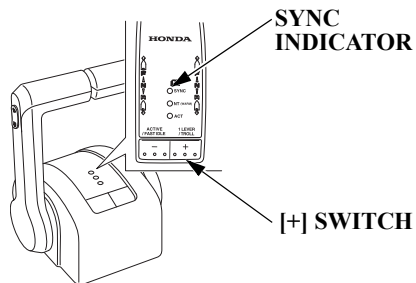

Shifting gear and the engine speed adjustment of the all outboard motors can be performed with one remote control lever when in one-lever mode.

If you press and hold the [+] switch when all remote control lever is in the NEUTRAL position, the mode changes to one-lever mode.

A long buzz sounds once and SYNC indicator comes on.

Trimming the Outboard Motor

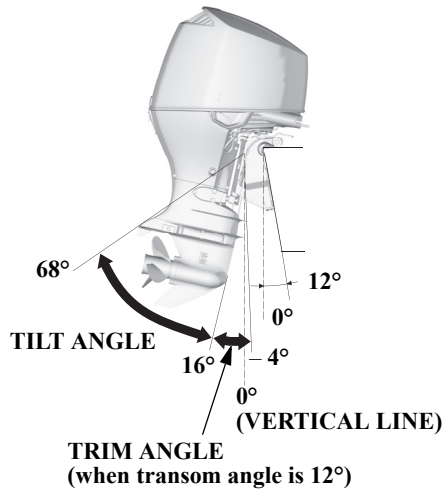

NOTE:

For multiple outboard motors, the trim/tilt angle of all outboard motors is adjusted at the same time by using the power trim/tilt switch on the remote control lever and the trim/tilt angle of each outboard motor is adjusted by using each power trim/tilt switch on the panel.

(D1 type)

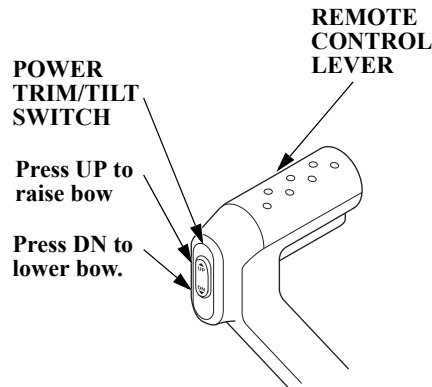

(D2 type)

SINGLE TYPE

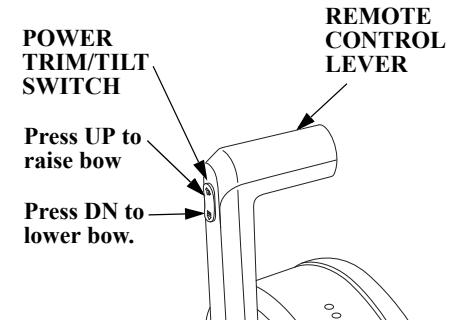

DUAL TYPE

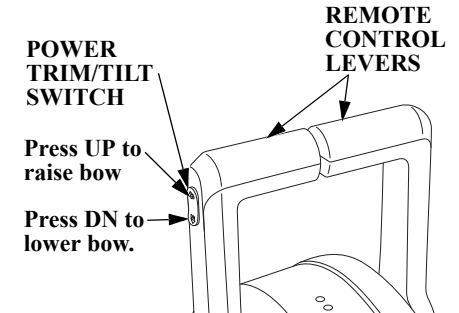

OPERATION

POWER TRIM/TILT SWITCH (R1 type)

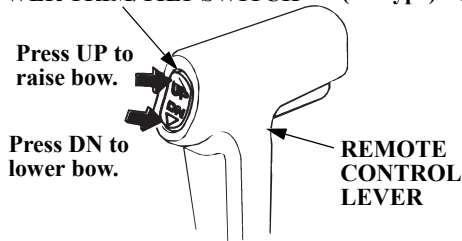

POWER TRIM/TILT SWITCH (R2 type)

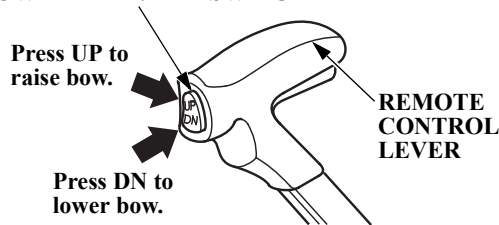

POWER TRIM/TILT SWITCH (R3 type)

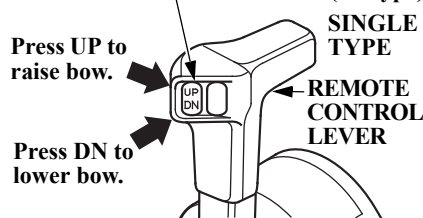

POWER TRIM/TILT SWITCH (LEFT) (RIGHT)

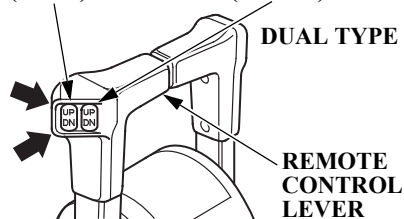

Consult an authorized Honda Outboard Motor dealer for the method to adjust the tilt limit switch. Press either UP or DN (down) of the power trim/tilt switch and tilt the outboard motor to the best position in compliance with the cruising conditions.

The power trim/tilt system operates when the switch is pressed, and it stops when the switch is released. To trim up slightly, press on UP momentarily but securely. To trim down slightly, press on DN (down) in the same manner.

PTT SWITCH PANEL

DUAL TYPE

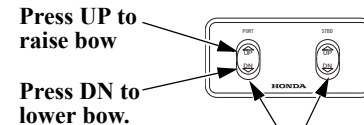

POWER TRIM/TILT SWITCH

TRIPLE TYPE

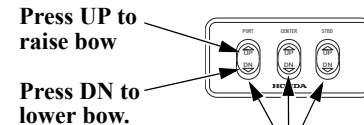

POWER TRIM/TILT SWITCH

NOTE:

For multiple outboard motors, the trim/tilt angle of all outboard motors is adjusted at the same time by using the power trim/tilt switch on the remote control lever and the trim/tilt angle of each outboard motor is adjusted by using each power trim/tilt switch on the panel.

⚠ WARNING

When the boat is mounted with the two outboard motors, adjust with the switch on the control lever side. Adjustment with the switch on the console side will impair the balance between the right and left outboard motors, which adversely affects operationability and stability of the outboard motors.

⚠ CAUTION

- Improper trim angle results in unstable steering condition.
- Do not trim excessively while cruising through rough waves, or it may cause an accident.
- Excessive trim angle can result in cavitation and racing of the propeller, and trimming up the outboard motor excessively can cause damage to the water pump.

OUTBOARD MOTOR TRIMMED TOO LOW

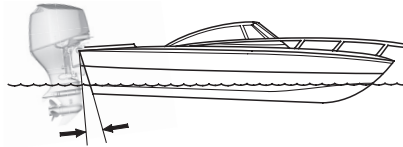

OUTBOARD MOTOR TRIMMED TOO HIGH

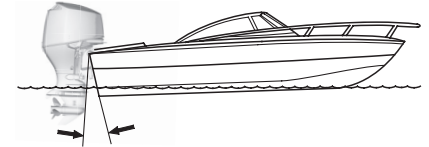

OUTBOARD MOTOR TRIMMED CORRECTLY

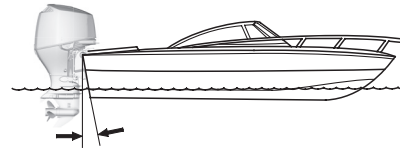

NOTE:

- Decrease the trim angle on high speed turns to reduce the possibility of propeller ventilation.
- Improper outboard motor trim angle can result in an unstable steering condition.

When cruising:

- (A) Into a high wind, trim the outboard motor down slightly to lower the bow and improve boat stability.
- (B) With a tail wind, trim the outboard motor up slightly to raise the bow and improve boat stability.
- (C) Through rough waves, do not trim the outboard motor too low or too high to avoid an unstable steering condition.

OPERATION

Trim Meter (optional equipment)

The trim meter indicates the trim angle of the outboard motor. Refer to the trim meter, and press the UP or DN (down) portion of the power trim/tilt switch to adjust the outboard motor trim angle to achieve boat performance and stability.

The illustration represents R1 type. Perform the same procedure for the other types.

- BOW TOO LOW DUE TO**
1. LOAD IN THE FRONT
2. OUTBOARD MOTOR TRIMMED
TOO LOW

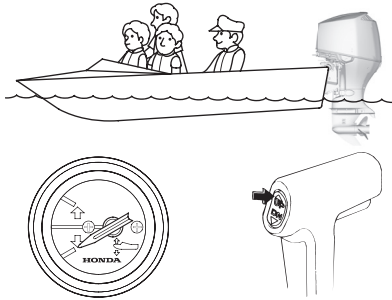

With the outboard motor trimmed low the trim meter will read as shown. To raise the bow increase the outboard motor trim angle by pressing the UP portion of the power trim/tilt switch.

- BOW TOO HIGH DUE TO**
1. LOAD IN THE REAR
2. OUTBOARD MOTOR TRIMMED
TOO HIGH

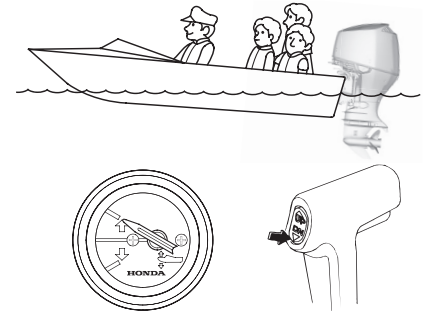

With the outboard motor trimmed high the trim meter will read as shown. To lower the bow decrease the outboard motor trim angle by pressing the DN (down) portion of the power trim/tilt switch.

Tilting the Outboard Motor

Tilt the outboard motor to prevent the propeller and gear case from hitting the bottom when the boat is beached or stopped in shallow water. Please tilt up simultaneously, when you mount the dual type outboard motor.

1. Move the shift lever or the control lever to the NEUTRAL position and stop the engine.
2. Press the UP of the power trim/tilt switch and tilt the outboard motor to the best position in compliance.

(D1 type)

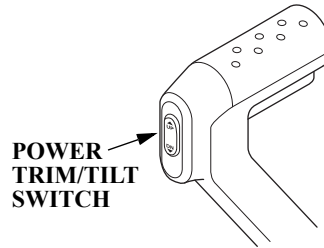

(D2 type)

SINGLE TYPE

**POWER
TRIM/TILT
SWITCH**

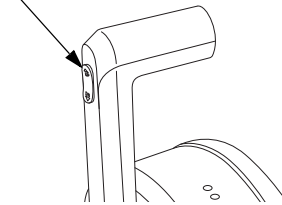

DUAL TYPE

**POWER
TRIM/TILT
SWITCH**

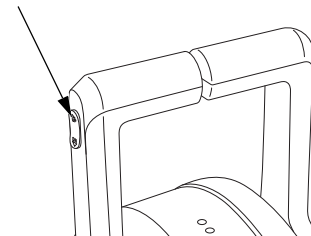

OPERATION

(R1 type)

POWER TRIM/TILT SWITCH

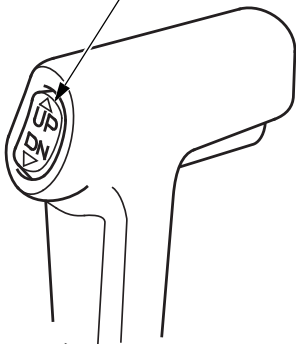

(R2 type)

POWER TRIM/TILT SWITCH

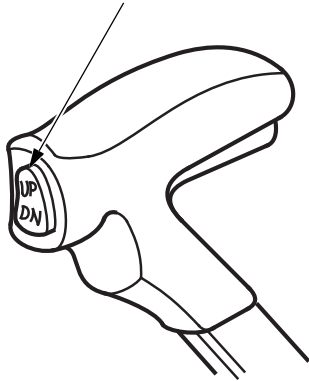

(R3 type)

SINGLE TYPE

POWER TRIM/TILT SWITCH

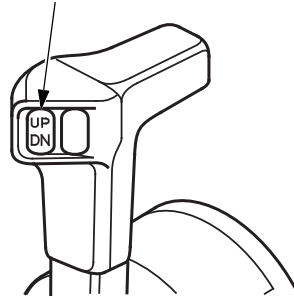

DUAL TYPE

POWER TRIM/TILT SWITCH
(LEFT) (RIGHT)

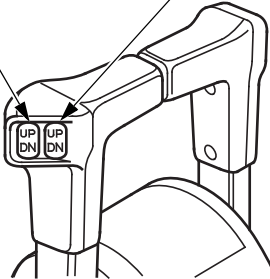

PTT SWITCH PANEL

DUAL TYPE

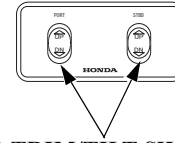

POWER TRIM/TILT SWITCH

TRIPLE TYPE

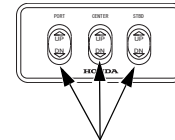

POWER TRIM/TILT SWITCH

NOTE:

For multiple outboard motors, the trim/tilt angle of all outboard motors is adjusted at the same time by using the power trim/tilt switch on the remote control lever and the trim/tilt angle of each outboard motor is adjusted by using each power trim/tilt switch on the panel.

Moorage



Tilt up the outboard motor using the tilt lock lever when mooring the boat. Shift the remote control lever into the NEUTRAL position and stop the engine before tilting up the outboard motor.

NOTE:

Before tilting up, leave the outboard motor in the running position for one minute after stopping the engine to drain the water from inside the engine.

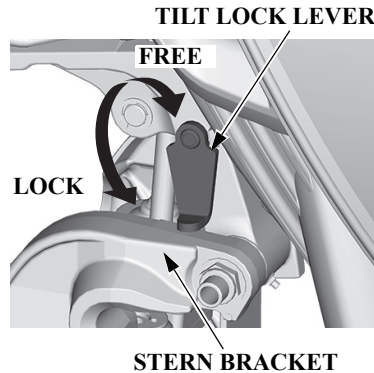

Stop the engine and disconnect the fuel line from the outboard motor before tilting the outboard motor.

1. Raise the outboard motor as full as it goes using the power trim/tilt switch.
2. Move the tilt lock lever to the LOCK position and lower the outboard motor until the lock lever contacts the stern bracket.
3. Press the DN (down) of the power trim/tilt switch and fully shorten the trim rods.

4. To tilt down, raise the outboard motor as far as it goes using the power trim/tilt switch, move the tilt lock lever to the FREE position, and lower the outboard motor to the designated position.

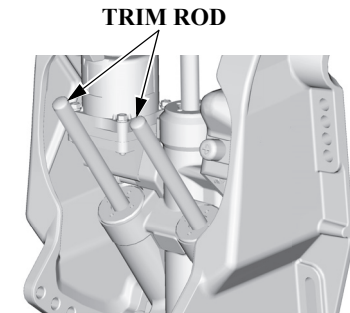

OPERATION

(R3 type) DUAL TYPE

POWER TRIM/TILT SWITCH
(LEFT) (RIGHT)

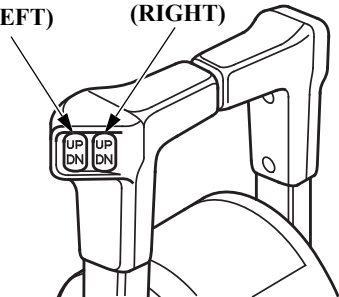

NOTE:

When the boat is mounted with the two outboard motors, tilt up the right and left outboard motors one by one using the switch. Set the tilt lock lever of one outboard motor at the LOCK position, then tilt up another outboard motor.

After tilting down the outboard motors, adjust the trim angle of the right and left outboard motors using the switch.

**Power Tilt Switch
(outboard motor pan)**

POWER TILT SWITCH

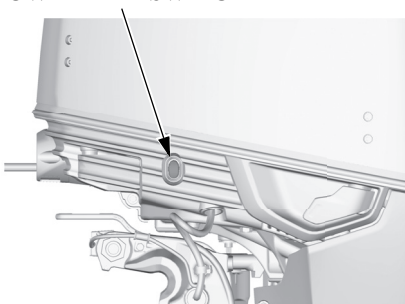

When you are away from the power trim/tilt switch on the control lever side, you can operate the power tilt switch on the outboard motor side. The switch operation is the same as that of the power trim/tilt switch on the remote control lever side.

⚠ CAUTION

Do not operate this power tilt switch on the outboard motor while sailing.

Manual Relief Valve

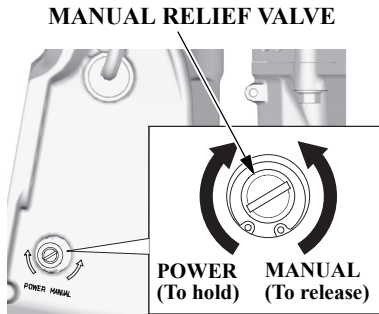

When power trim/tilt system does not operate because of dead battery or faulty power trim/tilt motor, the outboard motor can be manually tilted up or down by operating the manual relief valve.

To tilt the outboard motor manually, turn the manual relief valve under the stern bracket 1 or 2 turns counterclockwise using a screwdriver.

After tilting up/down manually, close the manual relief valve to lock the outboard motor in the position.

Check that no person is under the outboard motor before carrying out this operation because if the manual relief valve is loosened (turned counterclockwise) when the outboard motor is tilted up, the outboard motor will suddenly tilt down.

⚠ CAUTION

The manual relief valve must be tightened securely before operating the outboard motor or the outboard motor could tilt when operating in reverse.

OPERATION

Trim Tab Adjustment

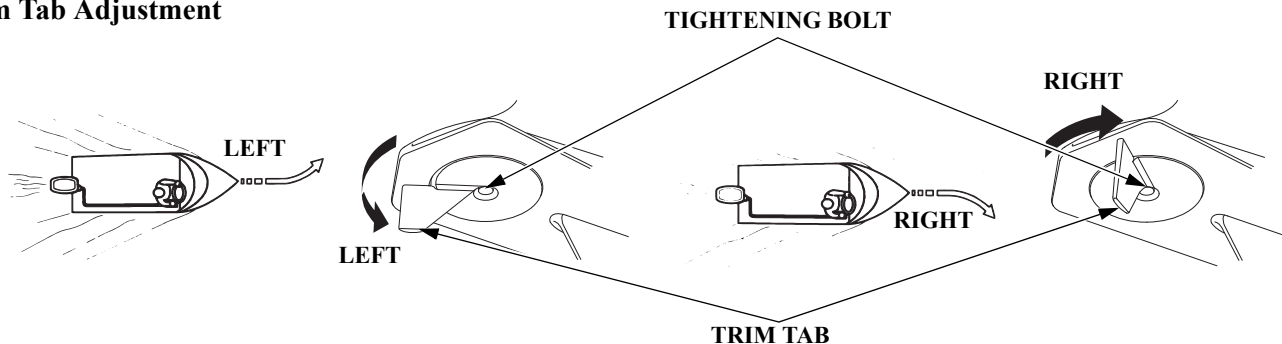

The trim tab is provided to adjust for “torque steer” which is a reaction of the propeller rotation or propeller torque. If during a high speed turn an unequal amount of effort is required to turn the boat right or left, adjust the trim tab so that an equal amount of effort is required.

Distribute the load evenly in the boat and run the boat in a straight course at full throttle. Slightly turn the steering wheel for both right and left turns to determine the amount of effort required.

If less effort is required to make left turns:

Loosen the trim tab tightening bolt and turn the rear end of the trim tab toward the left. Tighten the bolt securely.

If less effort is required to make right turns:

Loosen the trim tab tightening bolt and turn the rear end of the trim tab toward the right. Tighten the bolt securely.

Make small adjustments at a time and retest. Incorrect trim tab adjustment can cause adverse steering.

NOTICE

Painting or coating the anode will lead to rust and corrosion damage to the outboard motor.

Engine Protection System

<Engine Oil Pressure, Overheat, Water Contamination, PGM-FI and ACG Warning Systems>

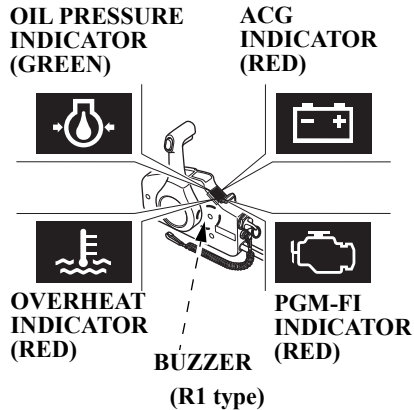

If the engine oil pressure drops and/or the engine overheats, either or both warning systems could be activated. When activated the engine speed will decrease gradually and the oil pressure indicator will turn OFF and the overheat indicator will turn ON. A continuous buzzer will sound on

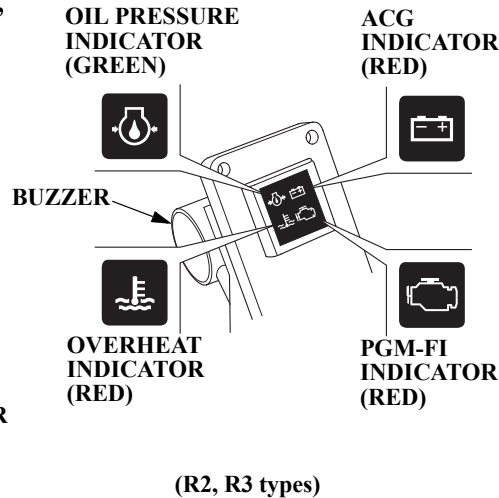

the remote control type.

The engine speed can not be increased with a larger throttle opening until the malfunction is corrected.

When the malfunction is corrected the engine speed will increase gradually.

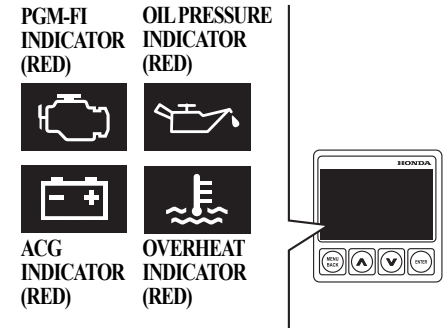

If the engine overheats, the engine will stop in 20 seconds after the engine protection system will limit engine speed.

Each warning system of PGM-FI, ACG, oil pressure, overheat, and water contamination is activated as described in the following table.

If using a flush-mount or top-mount switch panel without indicators, check the indicators displayed on an NMEA2000-compatible device.

OPERATION

(R1, R2, R3 types)





System Symptom	INDICATOR LIGHTS				BUZZER
	Oil pressure (Green)	Overheat (Red)	ACG (Red)	PGM-FI (Red)	CORRESPONDING SYSTEM
At starting	ON (2 sec)	ON (2 sec)	ON	ON (2 sec)	With the engine key turned on: ON (2 times)
During operation	ON	OFF	OFF	OFF	OFF
Low oil pressure	OFF	OFF	OFF	OFF	ON (continuously)
Overheat	ON	ON	OFF	OFF	ON (continuously)
ACG warning	ON	OFF	ON	OFF	alternating ON and OFF (at long intervals)
PGM-FI warning	ON*	OFF*	OFF	ON	alternating ON and OFF (at long intervals)
Water contamination	ON	OFF	OFF	OFF	alternating ON and OFF (at short intervals)

NOTE:

- Some indicator and/or buzzer will be activated at the same time due to the occurrence of a malfunction.
- For information about NMEA2000-compatible device displays, refer to the display device's manual.

*: Occasionally may blink due to the occurrence of a malfunction.

(Display Assy type)

System Symptom	INDICATOR				BUZZER	WARNING LEVEL	Power Reduction*
	Oil pressure (Red)	Overheat (Red)	ACG (Red)	PGM-FI (Red)	CORRESPONDING SYSTEM		
During operation	OFF	OFF	OFF	OFF	OFF	OFF	OFF
Low oil pressure	ON	OFF	OFF	OFF	ON (continuously)	 Warning level 1	ON
Overheat	OFF	ON	OFF	OFF	ON (continuously)	 Warning level 1	ON
ACG warning	OFF	OFF	ON	OFF	alternating ON and OFF (at long intervals)	 Warning level 2	OFF
PGM-FI warning	OFF	OFF	OFF	ON	alternating ON and OFF (at long intervals)	 Warning level 2	OFF
Water contamination	OFF	OFF	OFF	OFF	alternating ON and OFF (at short intervals)	 Warning level 2	OFF

NOTE:

Some indicator and/or buzzer will be activated at the same time due to the occurrence of a malfunction.

*: Refer to 110 page about power reduction.

OPERATION

When the oil pressure warning system is activated:

1. Stop the engine immediately and check the engine oil level (see page 61).
2. If the oil is up to the recommended level, restart the engine. If the oil pressure warning system stops after 30 seconds, the system is normal.

NOTE:

If the throttle was closed suddenly after cruising at full throttle, the engine speed may drop below the specified idle speed. This could cause the oil pressure warning system to activate momentarily.

3. If the oil pressure warning system stays activated after 30 seconds, return to the closest boat landing and contact your closest authorized Honda outboard motor dealer.

COOLING WATER CHECK HOLE

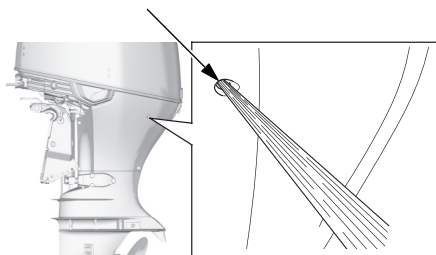

When the overheat warning system is activated:

1. Return the remote control lever to the N (neutral) position immediately. Check to see if water is flowing out of the cooling water check hole.
2. If water is flowing out of the cooling water check hole, continue idling for 30 seconds. If the overheat warning system stops after 30 seconds the system is normal.

NOTE:

If the engine is turned off after running at full throttle, the engine temperature may rise above normal. If the engine is restarted, shortly after being turned off, the overheat warning system could be activated momentarily.

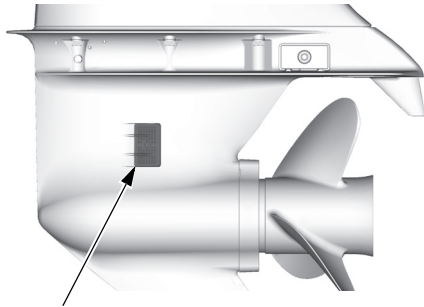

**COOLING WATER INTAKE PORT
(each side)**

3. If the overheat warning system stays activated, stop the engine. Tilt up the outboard motor and check the water intakes for obstructions. If there are no obstructions at the water intakes, return to the closest boat landing and contact your closest authorized Honda outboard motor dealer.

When the PGM-FI activated:

1. Consult with an authorized Honda outboard motor dealer.

When the ACG warning system is activated.

1. Check the battery (see page 68).
If the battery is OK, consult with an authorized Honda outboard motor dealer.

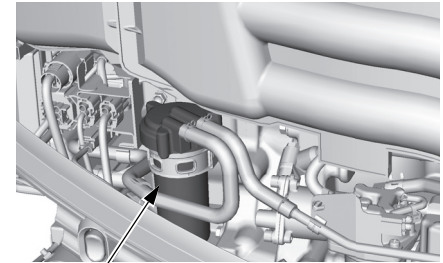

WATER SEPARATOR

When the water separator buzzer sounds:

1. Check the water separator for water contamination. If water is accumulated, clean them (see page 132).

OPERATION

<Over-rev Limiter>

This outboard motor is equipped with an engine over-rev limiter which activates when the engine speed increases excessively. The over-rev limiter can be activated while cruising, tilting up the outboard motor, or when ventilation occurs during a sharp turn.

When the over-rev limiter is activated:

1. Reduce the throttle opening immediately and check the trim angle.
2. If the trim angle is correct but the over-rev limiter stays activated, stop the engine, check the condition of the outboard motor, check to see if the correct propeller is installed and check it for damage.
Correct or service as necessary, by contacting your authorized Honda outboard motor dealer.

<Anodes>

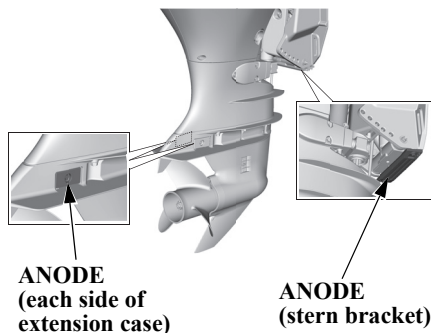

The anodes are a sacrificial material which helps to protect the outboard motor from corrosion.

NOTICE

Painting or coating the anodes will lead to rust and corrosion damage to the outboard motor.

There are also 2 small sacrificial anodes in the water passages of the engine block.

<Power Reduction>

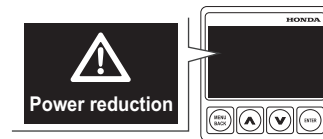

This outboard motor is equipped with the power reduction system which activates when the outboard motor has a serious problem.

The power reduction system decreases the engine speed to protect engine until the malfunction is corrected.

When one of the two systems of the remote control sensor is faulty, the power reduction system does not decrease the engine speed.

Shallow Water Operation

NOTICE

Excessive trim/tilt angle during operation can cause the propeller to raise out of the water and cause propeller ventilation and engine over-revving. Excessive trim/tilt angle can also damage the water pump and overheat the engine.

When operating in shallow water, tilt the outboard motor up to prevent the propeller and gear case from hitting the bottom (see page 99). With the outboard motor tilted up, operate the outboard motor at low speed.

Monitor the cooling water check hole for water discharge. Be sure that the outboard motor is not tilted so high that the water intakes are out of the water.

Multiple Outboard Motors

On boats equipped with more than one outboard motor, all motors normally operate at the same time.

If one or more motor(s) is stopped while the other(s) is running, put the stopped motor in “N” (neutral) and tilt it up so its propeller is above the water’s surface.

If the propeller of the stopped motor is left in the water, it may turn as the boat moves through the water, causing a reverse flow of water from the exhaust side. This reverse flow will happen if the stopped engine’s propeller is in the water, its gearshift is in “R” (reverse), and the boat is moving forward. Reverse flow can cause an engine malfunction.

9. STOPPING THE ENGINE

NOTICE

- After stopping the engine, be sure to turn **OFF** the ignition switch or power switch before turning **OFF** the battery switch. If the battery switch is turned **OFF** while the ignition switch or power switch is **ON**, the buzzer will sound three times briefly.

Emergency Engine Stop (D1, D2 types)

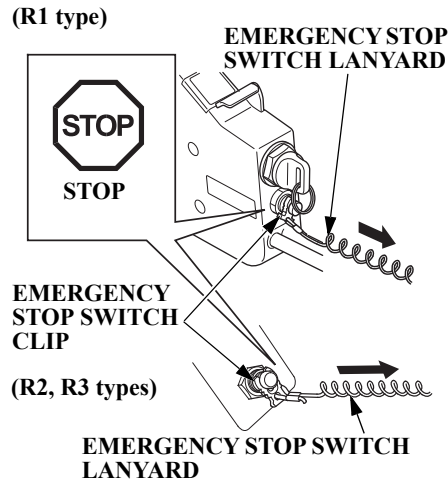
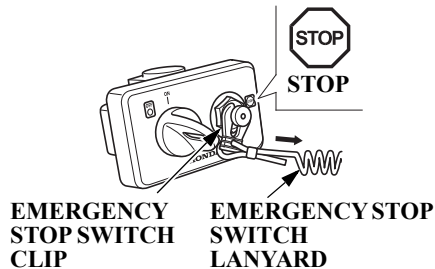

Pull the curl cord of the emergency stop switch and remove the lock plate from the switch; this will stop the engine.

If the emergency stop switch is activated while the engine is running, the engine will shut down abruptly and the boat will quickly decelerate, potentially causing occupants and objects to be thrown forward and/or overboard.

If the emergency stop switch is activated, the emergency stop switch clip must be reinserted before the engine can be restarted.

NOTE:

It is a good idea to stop the engine with the emergency stop switch lanyard from time to time to be sure that the emergency stop switch is operating properly.

Normal Engine Stop (D1, D2 types)

1. Move the shift lever to **NEUTRAL** position.

NOTE:

After sailing with the throttle fully open, cool down the engine by running it at the idle speed for a few minutes.

STOPPING THE ENGINE

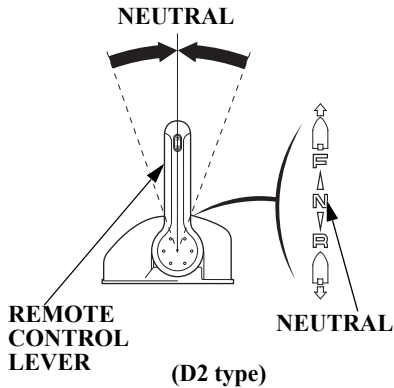
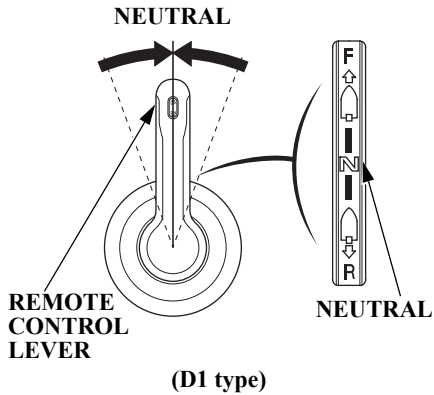

START/STOP SWITCH

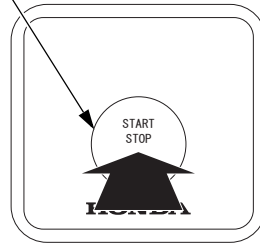

2. Push the start/stop switch to stop the engine.

NOTE:

In the event that the engine does not stop when the start/stop switch is pushed, disconnect the fuel line connector from the outboard motor.

(Normal Key type) (Honda Smart Key type)

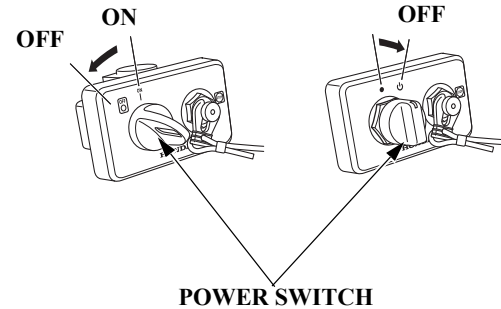

(Normal Key type)

3. Turn the power switch key to the OFF position, and then remove and store it.

(Honda Smart Key type)

3. Turn the power switch to the right or press the lock button on the Honda Smart Key to turn the power OFF.

If you are using a portable fuel tank, disconnect the fuel line if you will be storing or transporting the outboard motor.

STOPPING THE ENGINE

Normal Engine Stop

(D1, D2 without START/STOP Switch type)
(R1, R2, R3 types)

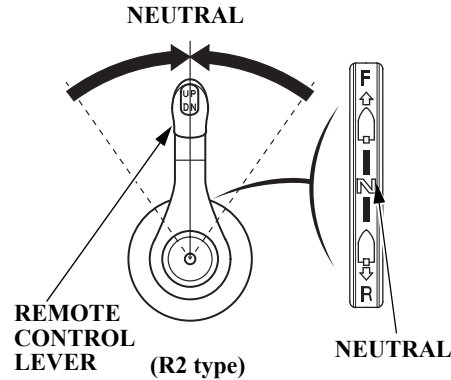
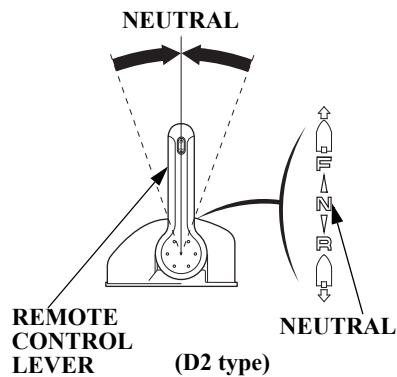
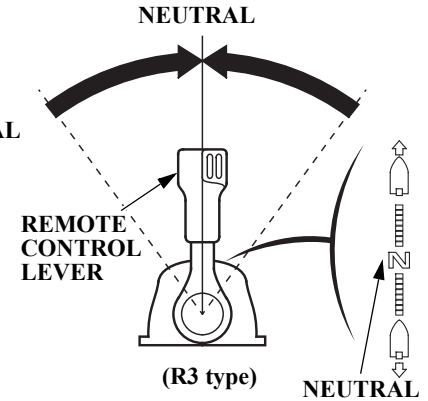
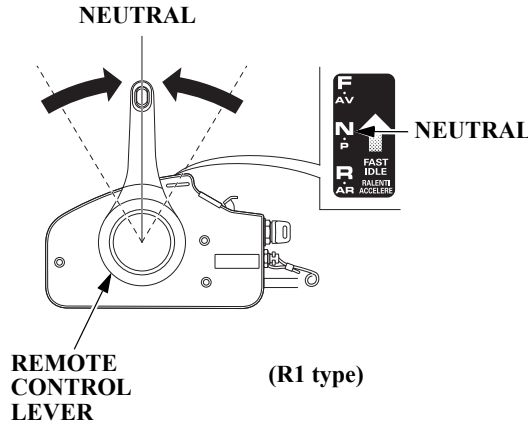
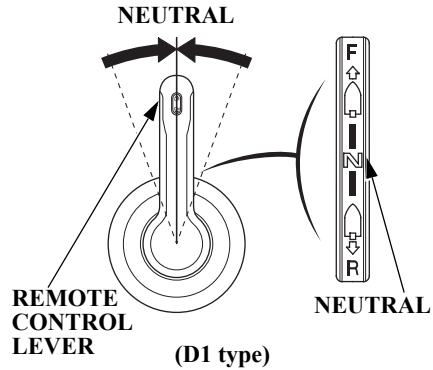

1. Move the shift lever to NEUTRAL position.

NOTE:

After sailing with the throttle fully open, cool down the engine by running it at the idle speed for a few minutes.

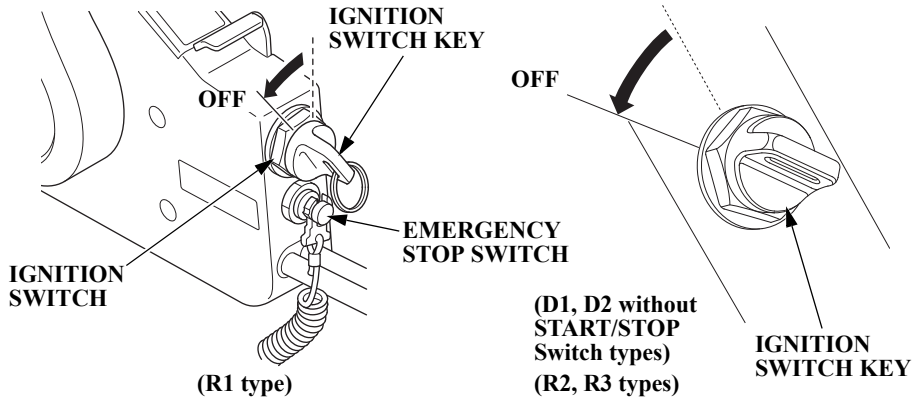

2. Turn the ignition switch key to the OFF position to stop the engine.

NOTE:

In the event that the engine does not stop when the ignition switch key is turned to OFF, push the emergency stop switch to stop the engine.

3. When the boat is not use, remove and store the ignition switch key. If you are using a portable fuel tank, disconnect the fuel line if you will be storing or transporting the outboard motor.

10. TRANSPORTING

Fuel Line Disconnection

Before transporting the outboard motor, disconnect and remove the fuel line.

▲ WARNING

Gasoline is extremely flammable, and gasoline vapor can explode, causing serious injury or death.

- Be careful not to spill fuel. Spilled fuel or fuel vapor may ignite. If any fuel is spilled, make sure the area is dry before the outboard motor.
- Keep heat, sparks, and flame away.

Transporting

ENGINE HANGERS

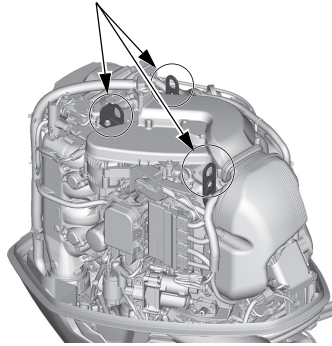

When transporting the outboard motor on a vehicle, perform the following.

1. Remove the engine cover.

HOIST HOOKS

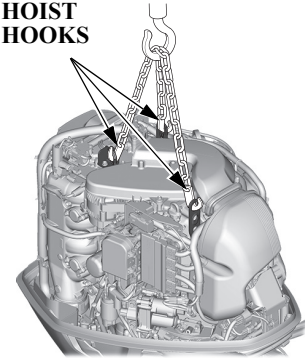

2. Set the hoist hooks against the engine hangers and hang the outboard motor to remove it from the boat.



OUTBOARD MOTOR STAND

3. Secure the outboard motor on an outboard motor stand with the mounting bolts and nuts.
4. Remove the hoist hook and reinstall the engine cover.

Trailer

When trailering or transporting the boat with the outboard motor attached, it is recommended that the outboard motor remain in normal running position.

NOTICE

Do not trailer or transport the boat with the outboard motor in the tilted position. The boat or outboard motor could be severely damaged if the outboard motor drops.

The outboard motor should be trailered in the normal running position. If there is insufficient road clearance in this position, then trailer the outboard motor in the tilted position using an outboard motor support device such as a transom saver bar, or remove the outboard motor from the boat.

11. CLEANING AND FLUSHING

After each use in salt water or dirty water, thoroughly clean and flush the outboard motor with fresh water.

NOTICE

Do not apply water or corrosion inhibitor directly to the electrical components under the engine cover, such as the AC generator, LAF sensor, or the AC generator belt. If water or corrosion inhibitor penetrates these components, they may be damaged. Before applying a corrosion inhibitor, cover the AC generator, belt and LAF sensor with a protective material to prevent damage.

Shut off the engine before performing the cleaning and flushing.

1. Disconnect the fuel line from the outboard motor.
2. Tilt down the outboard motor.



FLUSH PLUG CONNECTOR

3. Clean and wash the outside of the outboard motor with fresh water.
4. Remove the flush plug connector from the outboard motor.
5. Install the water hose joint (commercially available).

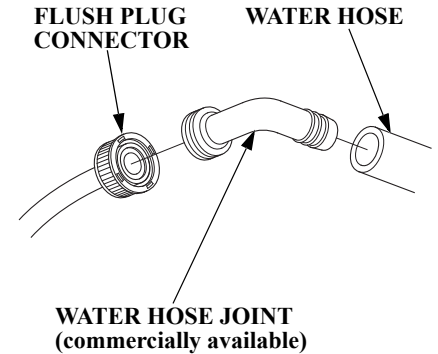

6. Connect a fresh water hose to the water hose joint.
7. Turn on the fresh water supply and flush the outboard motor for at least 10 minutes.
8. After flushing, remove the water hose and water hose joint and reinstall the flush plug connector.
9. Tilt up the outboard motor and move the tilt lock lever to the LOCK position.

Periodic maintenance and adjustment are important to keep the outboard motor in the best operating condition. Service and inspect according to the MAINTENANCE SCHEDULE.

⚠ WARNING

- Shut off the engine before performing any maintenance. If the engine must be run, make sure the area is well ventilated. Never run the engine in an enclosed or confined area. Exhaust contains poisonous carbon monoxide gas; exposure can cause loss of consciousness and may lead to death.
- Be sure to reinstall the engine cover, if it was removed, before starting the engine.

NOTICE

- **If the engine must be run, make sure there is water at least 100 mm (4 in) above the anticavitation plate, otherwise the water pump may not receive sufficient cooling water, and the engine will overheat.**
- **Use only Honda Genuine parts or their equivalents for maintenance or repair. The use of replacement parts which are not of equivalent quality may damage the outboard motor.**

MAINTENANCE

Tool Kit and Owner's Manual (Tool kit does not come with Counter Rotation Types)

The following tools and owner's manual are supplied with the outboard motor for maintenance, adjustment, and emergency repairs.

<Spare Emergency Stop Switch Clip (optional equipment)>

A spare emergency stop switch clip is available from your outboard motor dealer.

Always carry a spare emergency stop switch clip onboard. The spare clip may either be stored in the tool bag or in an easily accessible location on the boat.

OWNER'S MANUAL



**PHILLIPS/FLAT
SCREWDRIVER**



GRIP

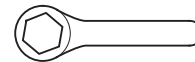

19 mm EYE WRENCH

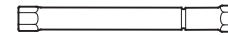

**SPARK PLUG
WRENCH**



**6 mm HEX.
WRENCH**

TOOL BAG

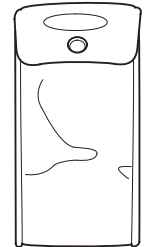

MAINTENANCE SCHEDULE

ITEM	REGULAR SERVICE PERIOD	Each use	After use	First month or 20 hrs.	Every 6 months or 100 hrs.	Every year or 200 hrs.	Every 2 years or 400 hrs.	Refer to page
	(3) Perform at every indicated month or operating hour interval, whichever comes first.							
Engine oil	Check level	o						61
	Change			o	o			123
Engine oil filter	Replace					o (2)		—
Gear case oil	Change			o (2)	o (2)			—
ACG belt	Check-adjust					o (2)		—
Throttle linkage and Control Cable (10)	Check-adjust			o (2)	o (2)			—
Idle speed	Check-adjust			o (2)	o (2)			—
Valve clearance	Check-adjust					o (2)		—
Spark plug (nickel)	Check-adjust/Replace				o			124 – 128
Spark plug (iridium) (Optional part)	Check					o		128
	Clean					o (2)		—
	Replace						o	128
Propeller and cotter pin	Check	o						65
Anode metal (Outside engine)	Check	o						69
Anode metal (Inside engine)	Check/Replace						o (2) (6)	—
Lubrication	Grease			o (1)	o (1)			129, 130
Fuel filter with water separator (Low pressure side)	Check	o			o			131
	Replace						o	132
Fuel filter (High pressure side)	Replace						o (2)	—

NOTE:

- (1) Lubricate more frequently when used in salt water.
- (2) These items should be serviced by your servicing dealer, unless you have the proper tools and are mechanically proficient. Refer to the Honda Shop Manual for service procedures.
- (3) For professional commercial use, log hours of operation to determine proper maintenance intervals.
- (6) When there is 1/3 or more consumption, please exchange.
- (10) Mechanical Remote Control type only.

MAINTENANCE

ITEM	REGULAR SERVICE PERIOD	Each use	After use	First month or 20 hrs.	Every 6 months or 100 hrs.	Every year or 200 hrs.	Every 2 years or 400 hrs.	Refer to page
	(3) Perform at every indicated month or operating hour interval, whichever comes first.							
Thermostat and thermostat cover	Check/Replace					o (2)		—
Fuel line	Check	o (8)						69
	Replace		Every 2 years (if necessary) (2) (9)					
Battery and cable connection	Check level-tightness	o						68, 135
Bolts and nuts	Check-tightness			o (2)	o (2)			—
Crankcase breather tube	Check					o (2)		—
Cooling water passages	Clean		o (4)					118
Coolant leak	Check	o						—
Water pump	Check					o (2)		—
Emergency stop switch	Check	o						112
Engine oil leak	Check	o						—
Each operation part	Check	o						—
Engine condition (5)	Check	o						—
Power Trim/Tilt	Check				o (2)			—
Shift cable (10)	Check-adjust			o (2)	o (2) (7)			—

NOTE:

- (2) These items should be serviced by your servicing dealer, unless you have the proper tools and are mechanically proficient. Refer to the Honda Shop Manual for service procedures.
- (3) For professional commercial use, log hours of operation to determine proper maintenance intervals.
- (4) When operating in salt water, turbid or muddy water, the engine should be flushed with clean water after each use.
- (5) Upon starting, check for unusual engine sounds and cooling water flowing freely from the check hole.
- (7) The user who performs shift operation frequently will recommend you exchange of a shift cable around three years.
- (8) Check the fuel line for leaks, cracks, or damage. If it is leaking, cracked, or damaged, take it to your servicing dealer for replacement before using your outboard.
- (9) Check the fuel line for leaks, cracks, or damage. Replace the fuel line if there are signs of leaks, cracks, or damage.
- (10) Mechanical Remote Control type only.

Engine Oil

Insufficient or contaminated engine oil adversely affects the service life of the sliding and moving parts.

Oil change interval:

20 operating hours after the date of purchase or first month for initial replacement, then every 100 operating hours or 6 months.

Oil capacity:

6.5 L (6.9 US qt, 5.7 Imp qt)

...when oil filter is not replaced

6.7 L (7.1 US qt, 5.9 Imp qt)

...when oil filter is replaced

Recommended Oil:

SAE 10W-30 engine oil or equivalent, API Service category SG, SH, SJ or SL.

Engine Oil Replacement

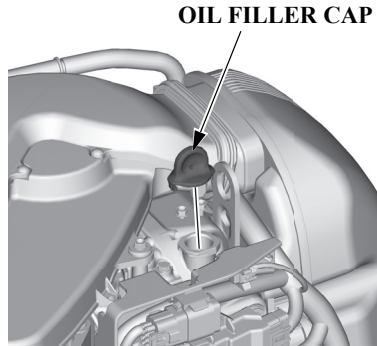

Drain the oil while the engine is still warm to assure rapid and complete draining.

1. Position the outboard motor vertically, and remove the engine cover (see page 60). Remove the oil filler cap.

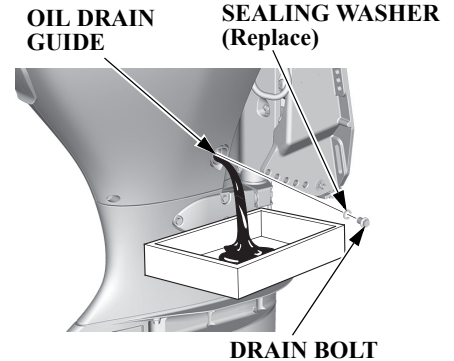

2. Place a suitable container under the guide.
3. Remove the engine oil drain bolt and sealing washer using the 12 mm wrench and drain the engine oil.

Install a new sealing washer and drain bolt, and tighten bolt securely.

TIGHTENING TORQUE:

23 N·m (2.3 kgf·m , 17 lbf·ft)

MAINTENANCE

OIL LEVEL DIPSTICK

UPPER
LEVEL
MARK

LOWER
LEVEL
MARK

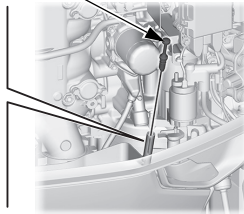

4. Refill to the upper level mark on the oil level dipstick with the recommended oil.

OIL FILLER CAP

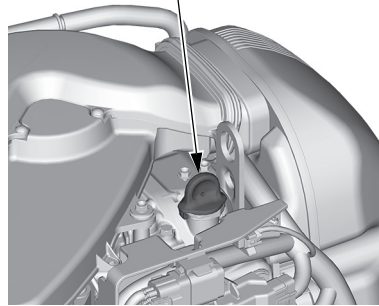

5. Insert the dipstick all the way in. Reinstall the oil filler cap securely. Do not overtighten.

NOTE:

Please dispose of used outboard motor oil in a manner that is compatible with the environment. We suggest you take it in a sealed container to your local service station for reclamation. Do not throw it in the trash or pour it on the ground.

Wash your hands with soap and water after handling used oil.

Spark Plugs

To ensure proper engine operation, the spark plug must be properly gapped and free of deposits.

⚠ CAUTION

The spark plug becomes very hot during operation and will remain hot for a while after stopping the engine. Allow the engine to cool before servicing the spark plug.

See page 128 for instructions of handling the Iridium spark plugs (optional parts).

<Standard Spark Plug>

Check-clean/Replace interval:
Every 100 operating hours or 6 months.

Recommended spark plug:
ZFR6K-11 (NGK)
KJ20DR-M11 (DENSO)

NOTICE

Use only the recommended spark plugs or equivalent. Spark plugs which have an improper heat range may cause engine damage.

<Inspection and Replacement>

1. Disconnect the battery negative (-) terminal.
2. Unlock and remove the engine cover (see page 60).

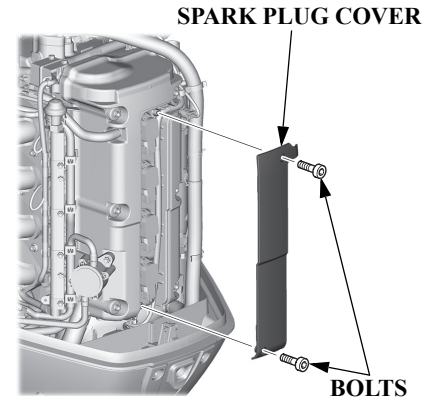

3. Remove the two bolts with the 6 mm hex wrench, and remove the spark plug cover.
4. Use a hex. wrench to remove the bolt holding the ignition coil. Move the ignition coil to a position that allows to remove the wire connector easily.

MAINTENANCE

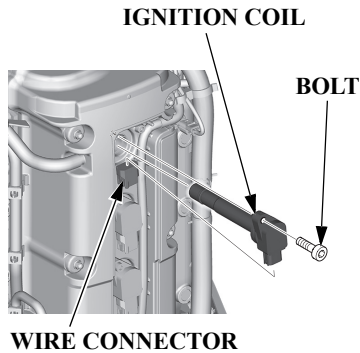

5. Disconnect the wire connector from the ignition coil by pushing on the lock tab and pulling on the connector. Pull on the plastic connector, not the wires.
6. Remove the ignition coil by pulling it up slightly. Take care not to give an impact or drop the ignition coil. Replace the ignition coil if dropped it.

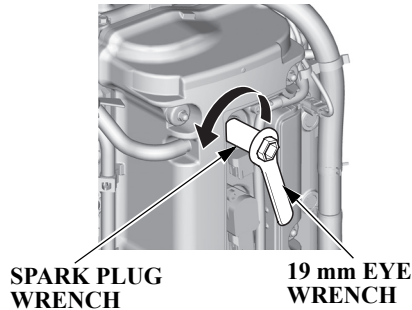

7. Use the spark plug wrench and 19 mm eye wrench to remove the spark plugs.

New plug

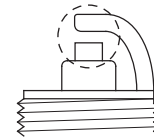

Plug needing replacement

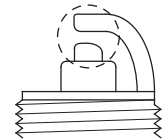

8. Inspect the spark plugs.
 - (1) If the electrodes are heavily corroded or carbon-soiled, clean with a wire brush.
 - (2) Replace a spark plug if the central electrode is worn. The spark plug can wear out in different ways. If the sealing washer shows signs of wear, or if the insulators are cracked or chipped, replace the spark plugs.

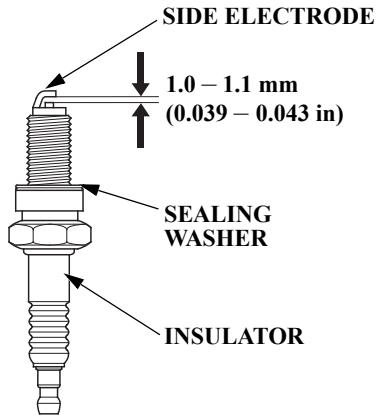

9. Measure the plug gaps with a wire-type feeler gauge. The gaps should be 1.0 – 1.1 mm (0.039 – 0.043 in). Correct as necessary by carefully bending the side electrode.
10. Thread the plugs in by hand to prevent cross threading.
11. After the spark plugs are seated, tighten with a spark plug wrench to compress the washers.

SPARK PLUG TORQUE:

18 N·m (1.8 kgf·m , 13 lbf·ft)

NOTE:

If installing new spark plugs, tighten 1/2 turn after the spark plugs seat to compress the washers.

If reinstalling used spark plugs, tighten 1/8 – 1/4 turn after the spark plugs seat to compress the washers.

NOTICE

The spark plugs must be securely tightened. An improperly tightened plug can become very hot and may cause engine damage.

12. Push the wire connector onto the ignition coil. Make sure it locks in place.
13. Install the ignition coil. Reinstall the bolt.
14. Repeat this procedure for the other three spark plugs.

15. Reinstall the covers. When reinstalling the covers, make sure not to jam the wire harnesses in between the covers and engine case.

MAINTENANCE

<Optional Parts: Iridium Spark Plug>

Check-clean/Replace interval:

Every 200 operating hours or every year.

Recommended spark plug:

IZFR6K11 (NGK)

SKJ20DR-M11 (DENSO)

NOTICE

Use only the recommended spark plugs or equivalent. Spark plugs which have an improper heat range may cause engine damage.

Installation and removal procedure of the Iridium spark plugs are the same as the standard spark plugs.

These spark plugs have an iridium coated center electrode. Be sure to observe the following when servicing iridium spark plugs.

- Do not clean the spark plugs. If an electrode is contaminated with accumulated objects or dirt, replace the spark plug with a new one. The cleaning of the iridium spark plugs consult with your serving dealer, unless the owner has the proper tools and is mechanically proficient.
- Use only a “wire-type feeler gauge” to check the spark plug gap if necessary. To prevent damaging the iridium coating of the center electrode, never use a “leaf-type feeler gauge.”
The gaps should be 1.0 – 1.3 mm (0.039 – 0.051 in).
- Do not adjust the spark plug gap. If the gap is out of specification, replace the spark plug with a new one.

Lubrication

Wipe the outside of the engine with a cloth dipped in clean oil. Apply marine anticorrosion grease to the following parts:

Lubrication interval:

20 hours or a month after the date of purchase for initial lubrication, then every 100 hours or 6 months.

NOTE:

- Apply anticorrosion oil to pivot surfaces where grease cannot penetrate.
- Lubricate more frequently when used in salt water.

**THROTTLE LINK/PIVOT/
PLATE
(MECHANICAL WIRE TYPE)**

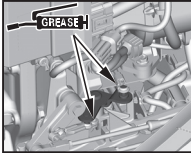

**THROTTLE ROD/LINK
(MECHANICAL WIRE TYPE)**

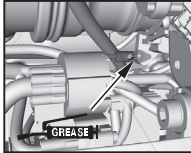

TILT BRACKET

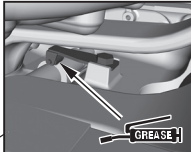

**ENGINE COVER
LOCK PLATE**

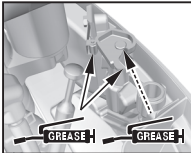

TILT SHAFT

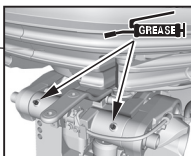

Apply grease to the back of the engine cover lock plate as well.

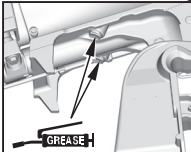

**PTT THRUST
RECEIVER**

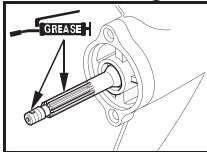

PROPELLER SHAFT

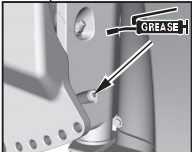

SWIVEL CASE

MAINTENANCE

**THROTTLE ARM/SHIFT ARM/PIVOT
PLATE/NEUTRAL SWITCH/CLICK ARM
ROLLER (MECHANICAL WIRE TYPE)**

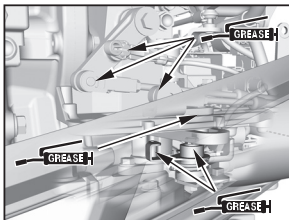

**SHIFT PIVOT/BRAKET/SHIFT ARM/
CLICK ARM ROLLER (DBW TYPE)**

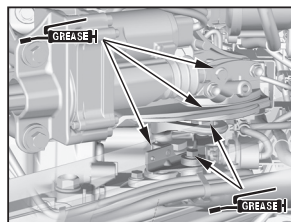

TILT LOCK LEVER

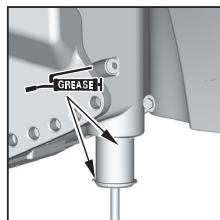
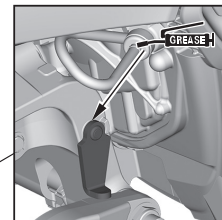

SWIVEL SHAFT

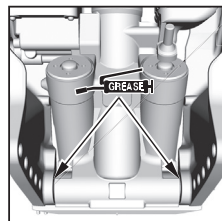

**LOWER CYLINDER
BUSH/COLLAR**

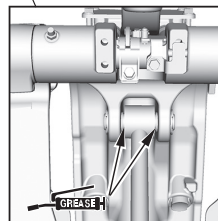

**UPPER CYLINDER PIN/
BUSH**

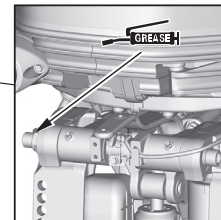

TILT SHAFT THREAD

Fuel Filter with Water Separator

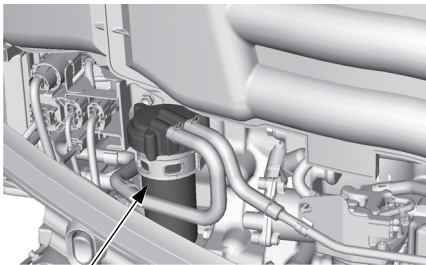

**FUEL FILTER with
WATER SEPARATOR**

The fuel filter with water separator is located below the intake manifold. Water or sediment accumulated in the fuel filter with water separator can cause loss of power or hard starting. Check and replace the fuel filter with water separator periodically. Clean it or consult with an authorized Honda outboard motor dealer for cleaning.

Inspection interval:

Every 100 operating hours or 6 months.

Replacement interval:

Every 400 operating hours or 2 years

⚠ WARNING

Gasoline is extremely flammable, and gasoline vapor can explode, causing serious injury or death. Do not smoke or allow flames or sparks in your working area.

- Always work in a well-ventilated area.
- Be sure that any fuel drained from the outboard motor is stored in a safe container.
- Be careful not to spill fuel when replacing the filter. Spilled fuel or fuel vapor may ignite. If any fuel is spilled, make sure the area is dry before starting the engine.
- **KEEP OUT OF REACH OF CHILDREN.**

MAINTENANCE

<Inspection>

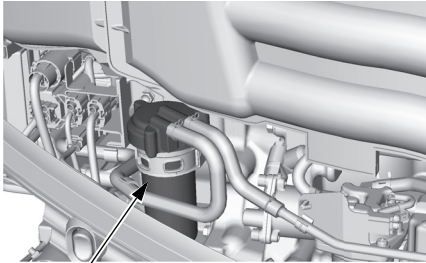

**FUEL FILTER with
WATER SEPARATOR**

1. Remove the engine cover (see page 60).
2. Looking through the translucent strainer cup, check the fuel filter with water separator for water accumulation and clogging. If the fuel filter with water separator is clogged, refer to page 133 to remove the filter and clean it.

If a water is remained in the fuel filter with water separator, refer to page 133 to remove the strainer cup and empty the water from the inside of the cup.

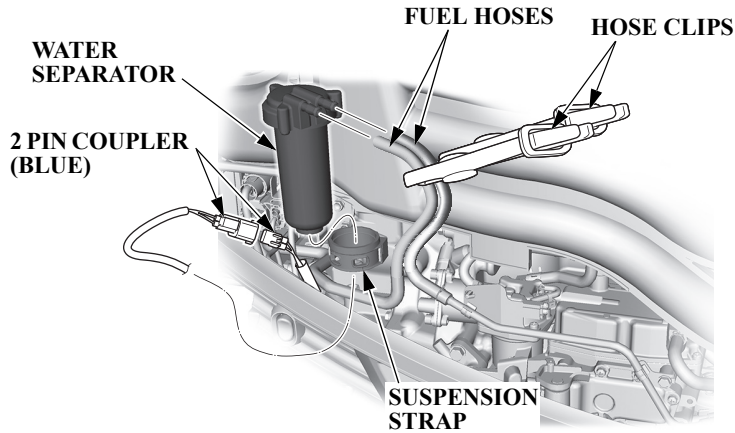

<Replacement>

1. Remove the engine cover (see page 60).
2. Disconnect the 2-pin coupler (blue).

3. Remove the suspension strap from the fuel filter with water separator bracket, then remove the suspension strap from the fuel filter with water separator.
4. Bind the two fuel tubes with the tube clips to prevent the fuel leakage, disconnect the fuel tubes.

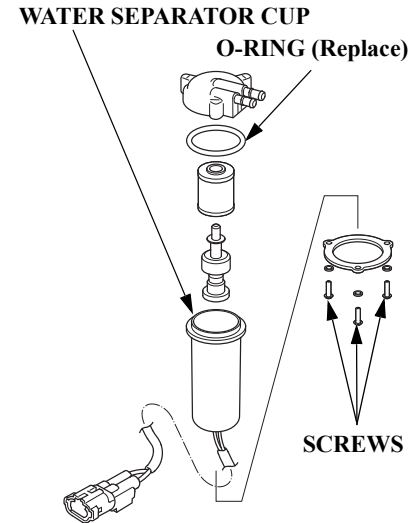

5. Remove the three screws holding the fuel filter with water separator, delete the water or deposit from the inside of the cup.
6. Thoroughly clean the cup, and replace with a new fuel filter.
7. Reassemble the water separator in the reverse order of removal. Use a new O-ring.
TIGHTENING TORQUE:
3.4 N·m (0.34 kgf·m, 2.5 lbs·ft)

MAINTENANCE

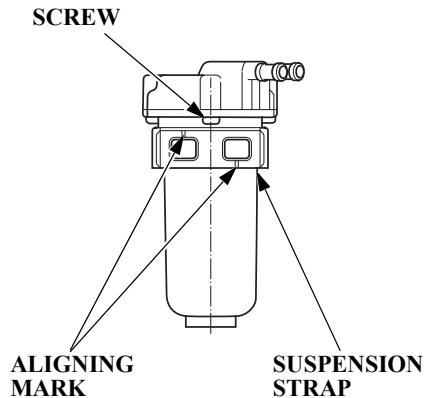

8. Align the aligning mark as shown in the figure, when installing the suspension strap on the fuel filter with water separator.
9. Prime the engine using the priming bulb (see page 70). Check for fuel leaks. Repair any fuel leaks if necessary.

NOTE:

If the buzzer sounds, water or sediment accumulation is found to be caused by excessive water or sediment accumulated in the fuel filter, inspect the fuel tank. Clean the fuel tank if necessary.

EMISSION CONTROL SYSTEM

The combustion process produces carbon monoxide and hydrocarbons. Control of hydrocarbons is very important because under certain conditions, they react to form photochemical smog when subjected to sunlight. Carbon monoxide does not react in the same way, but it is toxic.

Problems that May Affect Outboard Motor Emissions

If you are aware of any of the following symptoms, have the outboard motor inspected and repaired by your authorized Honda dealer:

1. Hard starting or stalling after starting
2. Rough idle
3. Misfiring or backfiring during acceleration
4. Poor performance (driveability) and poor fuel economy

Battery

NOTICE

Battery handling differs according to the type of the battery and the instructions described below might not be applicable to the battery of your outboard. Refer to the battery manufacturer’s instructions.

WARNING

Batteries produce explosive gases: If ignited, an explosion can cause serious injury or blindness. Provide adequate ventilation when charging.

- CHEMICAL HAZARD: Battery electrolyte contains sulfuric acid. Contact with eyes or skin, even through clothing, may cause severe burns. Wear a faceshield and protective clothing.

- Keep flames and sparks away, and do not smoke in the area. ANTIDOTE: If electrolyte gets into your eyes, flush thoroughly with warm water for at least 15 minutes and call a physician immediately.
- POISON: Electrolyte is poison. ANTIDOTE:
 - External: Flush thoroughly with water.
 - Internal: Drink large quantities of water or milk. Follow with milk of magnesia or vegetable oil, and call a physician immediately.
- KEEP OUT OF REACH OF CHILDREN.

Battery posts, terminals, and related accessories contain lead and lead compounds. Wash your hands after handling.

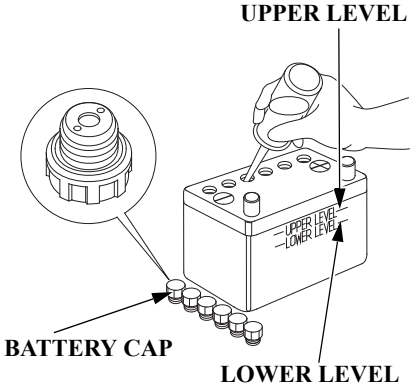

<Battery Fluid Level> Check whether the battery fluid is between the upper and lower levels, and check the vent hole in the battery caps for clogging. If the battery fluid is near or below the lower level, add the distilled water to the upper level.

MAINTENANCE

<Battery Cleaning>

1. Disconnect the battery cable at the battery negative (-) terminal, then at the battery positive (+) terminal.
2. Remove the battery and clean the battery terminals and battery cable terminals with a wire brush or sand paper.

Clean the battery with a solution of baking soda and warm water, taking care not to get the solution or water in the battery cells. Dry the battery thoroughly.

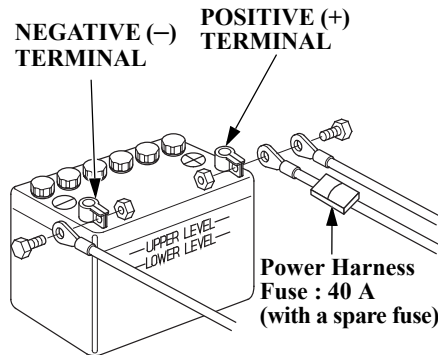

3. Connect the battery positive (+) cable to the battery positive (+) terminal, then the battery negative (-) cable to the battery negative (-) terminal. Tighten the bolts and nuts securely. Coat the battery terminals with grease.

⚠ CAUTION

When disconnecting the battery cable, be sure to disconnect at the battery negative (-) terminal first. To connect, connect at the positive (+) terminal first, then at the negative (-) terminal. Never dis/connect the battery cable in the reverse order, or it causes a short circuit when a tool contacts the terminals.

Fuse

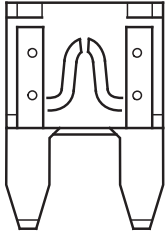

BLOWN FUSE

If the fuse blows, running the engine will not charge the battery. Before replacing the fuse, check the current ratings of the electrical accessories and ensure that there are no abnormalities.

⚠ WARNING

- Never use a fuse with a different rating from that specified. Serious damage to the electrical system or a fire may result.
- Disconnect the battery cable at the battery negative (-) terminal before replacing the fuse. Failure to do so may cause a short circuit.

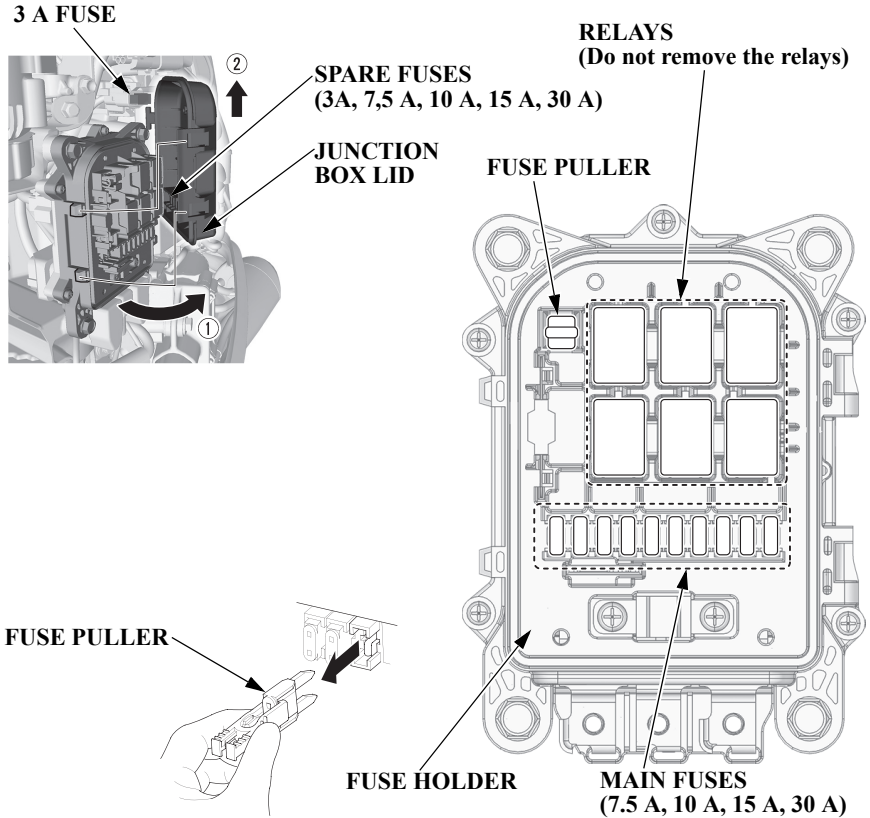

MAINTENANCE

NOTICE

If the fuse is blown, check the cause, then replace the fuse with a spare fuse of the same rated capacity. Unless the cause is found, the fuse may blow again.

Main Fuse

<Replacement>

A spare fuse is located on the reverse side of the junction box lid.

1. Stop the engine.
2. Remove the engine cover.
3. Remove the junction box lid and pull the old fuse out of the clip with the fuse puller supplied in the fuse holder.
4. Push a new fuse into the clips.
5. Reinstall the junction box lid, and the engine cover.
6. Reconnect the battery.

DESIGNATED FUSE:

7.5 A, 10 A, 15 A, 30 A

Mechanical wire type

Fuse No.	Rating	Component(s) or Circuit(s) Protected
1	100 A	ACG, Battery
4	30 A	STARTER SOLENOID, AND RELAYS IN JUNCTION BOX
5	10 A	Power tilt relay, Warning buzzer, Indicator, Meter
8	10 A	Fuel pump (High pressure side)
9	15 A	Injector, ECU
10	10 A	DLC, Fuel pump (Low pressure side)
11	15 A	PTC
	3 A	Battery switch OFF notification

DBW type

Fuse No.	Rating	Component(s) or Circuit(s) Protected
1	100 A	ACG, Battery
2	15 A	GROUND
3	7.5 A	12 V Accessory
4	30 A	STARTER SOLENOID, AND RELAYS IN JUNCTION BOX
5	7.5 A	REMOTE CONTROL SYSTEM
6	30 A	SHIFT ACTUATOR
7	15 A	THROTTLE BODY
8	10 A	Fuel pump (High pressure side)
9	15 A	Injector, ECU
10	10 A	DLC, Fuel pump (Low pressure side)
11	15 A	PTC
	3 A	Battery switch OFF notification

3 A Fuse

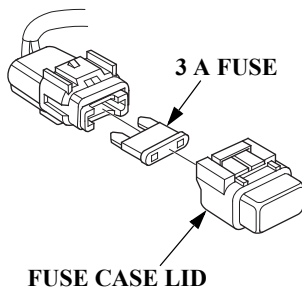

<Replacement>

A spare fuse is located on the reverse side of the junction box lid.

1. Stop the engine.
2. Remove the engine cover.
3. Remove the fuse case lid.
4. Remove the old fuse.
5. Install a new fuse with “3 A”.
6. Be sure to check the fuse case lid is securely locked.

DESIGNATED FUSE:

3 A

ACG Fuse

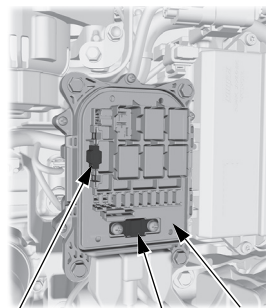

SPARE FUSE (100 A) FUSE HOLDER
FUSE (100 A)

NOTICE

Disconnect the battery cable at the battery terminal before checking or replacing the ACG fuse.

<Replacement>

A spare fuse is located in the fuse holder.

1. Stop the engine.
2. Remove the engine cover.

3. Remove the junction box lid (see page 137).
4. Remove the old fuse by removing two 5 mm screws.
5. Install a new fuse with “100A”.
6. Reinstall the junction box lid, and the engine cover.
7. Reconnect the battery.

DESIGNATED FUSE:

100A

Power Harness

1. Stop the engine.
2. Disconnect the battery cable and the power harness.
3. Open the fuse cover.
4. Pull the old fuse out of the clip with the fuse puller supplied in the fuse box.
5. Push a new fuse (40 A) into the clip.
6. Close the fuse cover.

MAINTENANCE

Propeller

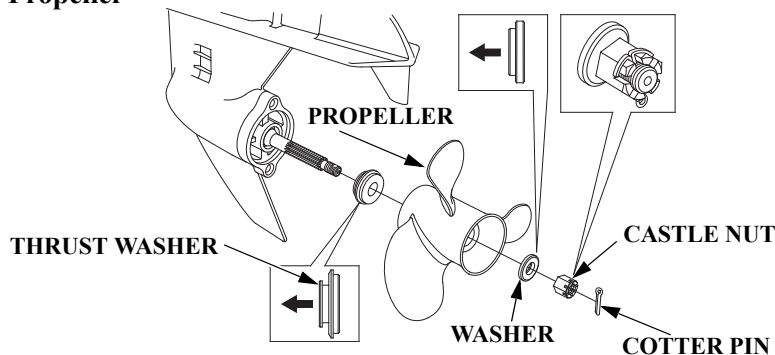

If the propeller is damaged by striking a rock, or other obstacle, replace the propeller as follows.

⚠ WARNING

- When replacing, remove the emergency stop switch clip to prevent an accidental startup of the engine.
- The propeller is thin and sharp. To protect your hands, wear the heavy gloves during replacement.

Replacement

1. Remove the cotter pin then remove the 18 mm castle nut, washer, propeller and thrust washer.
2. Install the new propeller in the reverse sequence to removal.

3. Tighten the castle nut with your hand first until the propeller has no play. Then, tighten the castle nut again with a tool until the groove in the castle nut aligns with the cotter pin hole. (Note that this tool is not included in the tools that come together with the outboard motor.)

TIGHTENING TORQUE:

1.0 N·m (0.1 kgf·m, 0.7 lbf·ft)

UPPER LIMIT OF TORQUE:

44 N·m (4.5 kgf·m, 33 lbf·ft)

4. Be sure to replace the cotter pin with a new one.

NOTE:

- Install the thrust washer with the grooved side toward the gear case.
- Use a genuine Honda cotter pin and bend the pin ends as shown.

Inspect After Operating

1. Stop the engine and remove the engine cover (see page 60).
2. Confirm the cooling water leakage from the engine.

Submerged Outboard Motor

A submerged outboard motor must be serviced immediately after it is recovered from the water in order to minimize corrosion.

If there is a Honda outboard motor dealer nearby, take the outboard motor immediately to the dealer. If you are far from a dealer, proceed as follows:

1. Remove the engine cover, and rinse the outboard motor with fresh water to remove salt water, sand, mud, etc.
2. Drain the vapor separator as described on page 143.

3. Change the engine oil (see page 123). If there was water in the engine crankcase, or if the used engine oil showed signs of water contamination, then a second engine oil change should be performed after running the engine for 1/2 hour.
4. Remove the spark plugs (see page 124). Operate the starter to expel water from the engine's cylinder.

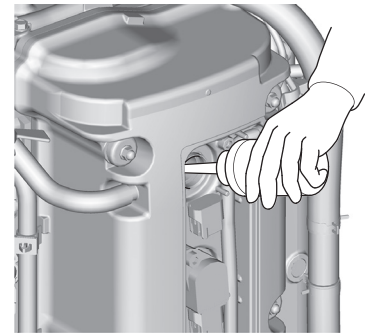

MAINTENANCE

5. Pour a teaspoon of engine oil into each spark plug hole to lubricate the inside of the cylinders. Reinstall the spark plugs.

NOTICE

If the outboard motor was running when it submerged, there may be mechanical damage, such as bent connecting rods. If the engine binds when cranked, do not attempt to run the outboard motor until it has been repaired.

6. Install the engine cover and lock the latch securely (see page 60).
7. Attempt to start the engine.
- If the engine fails to start, remove the spark plugs, clean and dry the electrodes, then reinstall the spark plugs and attempt to start the engine again.
 - If there was water in the engine crankcase, or the used engine oil showed signs of water contamination, then a second engine oil change should be performed after running the engine for 1/2 hour.
 - If the engine starts, and no mechanical damage is evident, continue to run the engine for 1/2 hour or longer (be sure the water level is at least 100 mm (4 in) above the anticavitation plate).

8. As soon as possible, take the outboard motor to a Honda outboard motor dealer for inspection and service.

For longer service life of the outboard motor, have your outboard motor serviced by an authorized Honda outboard motor dealer before storage. However, the following procedures can be performed by you, the owner, with a minimum of tools.

Fuel

NOTE:

Gasoline spoils very quickly depending on factors such as light exposure, temperature and time. In worst cases, gasoline can be contaminated within 30 days. Using contaminated gasoline can seriously damage the engine (fuel system clogged, valve stuck). Such damage due to spoiled fuel is disallowed from coverage by the warranty.

To avoid this please strictly follow these recommendations:

- Only use specified gasoline (see page 63).
- Use fresh and clean gasoline.

- To slow deterioration, keep gasoline in a certified fuel container.
- If long storage (more than 30 days) is foreseen, drain fuel tank and vapor separator.

Vapor Separator Draining

WARNING

Gasoline is extremely flammable, and gasoline vapor can explode, causing serious injury or death. Do not smoke or allow flames or sparks in your working area.

- Be careful not to spill fuel. Spilled fuel or fuel vapor may ignite. If any fuel is spilled, make sure the area is dry before storing or transporting the outboard motor.
- Do not smoke or allow flames or sparks where fuel is drained or stored.
- KEEP OUT OF REACH OF CHILDREN.

STORAGE

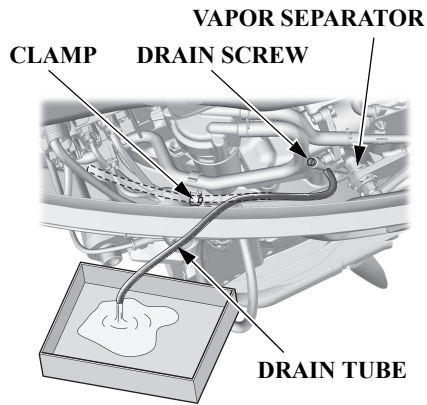

1. Remove the engine cover.
2. Unhook the drain tube from the clamp.
3. Set the end of the tube toward the outside of the engine undercase. Draining the fuel becomes easier when the front end of the drain tube is as low as possible.
4. Loosen the vapor separator drain screw.

5. Tilt up the outboard motor.
6. When the gasoline starts to flow out of the drain tube, tilt up the outboard motor and hold it in the position until the gasoline stops flowing. After draining the gasoline completely, return the outboard motor to the vertical position.
7. After draining thoroughly, tighten the drain screw securely.
8. Clamp the drain tube on the clamp.

Engine Oil

1. Change the engine oil (see page 123).
2. Remove the spark plugs (see page 124), and remove the clip from the emergency stop switch.
3. Pour 1 – 2 teaspoons (5 – 10 cm³) of clean engine oil into the cylinder.
4. Rotate the engine a few revolutions to distribute the oil in the cylinders.
5. Reinstall the spark plugs (see page 126).

Battery Storage

NOTICE

Battery handling differs according to the type of the battery and the instructions described below might not be applicable to the battery of your outboard motor. Refer to the battery manufacturer's instructions.

⚠ WARNING

Batteries produce explosive gases: If ignited, an explosion can cause serious injury or blindness. Provide adequate ventilation when charging.

- **CHEMICAL HAZARD:** Battery electrolyte contains sulfuric acid. Contact with eyes or skin, even through clothing, may cause severe burns. Wear a faceshield and protective clothing.

- Keep flames and sparks away, and do not smoke in the area. ANTIDOTE: If electrolyte gets into your eyes, flush thoroughly with warm water for at least 15 minutes and call a physician immediately.
- **POISON:** Electrolyte is poison. ANTIDOTE
 - External: Flush thoroughly with water.
 - Internal: Drink large quantities of water or milk. Follow with milk of magnesia or vegetable oil, and call a physician immediately.
- **KEEP OUT OF REACH OF CHILDREN.**

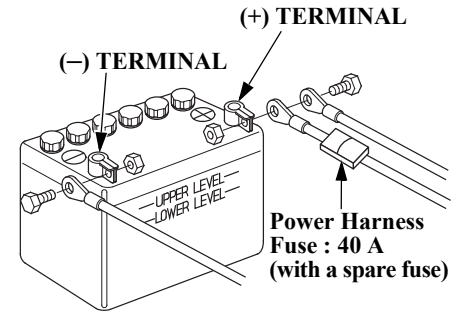

1. Disconnect the battery cable at the battery negative (-) terminal, then at the battery positive (+) terminal.
2. Remove the battery and clean the battery terminals and battery cable terminals with a wire brush or sand paper. Clean the battery with a solution of baking soda and warm water, taking care not to get the solution of water in the battery cells. Dry the battery thoroughly.

STORAGE

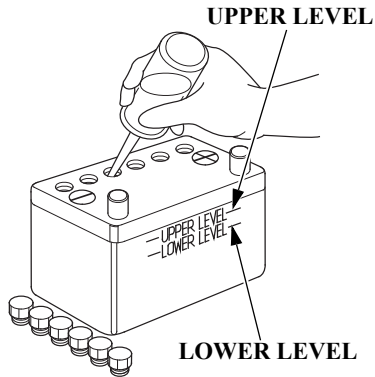

3. Fill the battery with distilled water to the upper level line. Never overfill the battery.
4. Store the battery on a level surface in a cool, dry, well ventilated place out of direct sunlight.
5. Once a month, check the specific gravity of the electrolyte and recharge as required to prolong battery life.

Outboard Motor Position

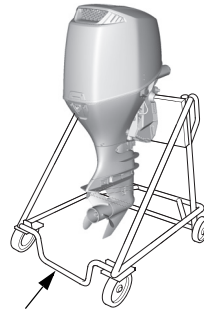

OUTBOARD MOTOR STAND

Transport and store the outboard motor either vertically or horizontally, as shown above. Attach the stern bracket to stand and secure the outboard motor with bolts and nuts. Store the outboard motor in a well-ventilated area free from direct sunlight and humidity.

Vertical transport or storage:
Attach the stern bracket to a stand.

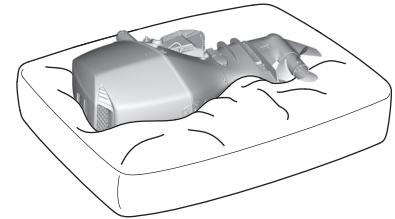

(Port side turned down as shown.)

Horizontal transport or storage:
Rest the outboard motor on a cushion of protective material.

⚠ CAUTION

Do not place the outboard motor on its side during a prolonged period of storage. If you are obliged to place the outboard motor on its side, drain the engine oil, protect the outboard motor by wrapping it with the urethane material or the blanket as shown.

To protect the environment, do not dispose of this product, battery, engine oil, etc. carelessly by leaving them in the waste. Observe the local laws and regulations or consult your dealer for disposal.

15. TROUBLESHOOTING

WARNING SYSTEM COMES ON

SYMPTOM	POSSIBLE CAUSE	REMEDY
<p>Overheat warning system comes on:</p> <ul style="list-style-type: none">• Overheat indicator comes on.• Overheat warning buzzer sounds.• Engine speed decreases and stops at last.• Engine speed cannot be increased by opening the throttle.• Engine will stop in 20 seconds after engine speed is limited.	Cooling water intake port clogged.	Clean the cooling water intake port.
	Spark plug has improper heat range.	Replace the spark plug (see page 124 – 128).
	<ul style="list-style-type: none">• Faulty water pump.• Thermostat clogged.• Faulty thermostat.• Cooling water passage clogged.• Exhaust gas invades cooling system.	Consult with an authorized Honda outboard motor dealer.
<p>Oil pressure warning system comes on:</p> <ul style="list-style-type: none">• Oil pressure indicator does not come on.• Oil pressure warning buzzer sounds.• Engine speed decreases.• Engine speed cannot be increased by opening the throttle.	Shortage of engine oil	Add engine oil to the specified level (see page 61).
	Improper engine oil is used.	Change the engine oil (see page 123).

TROUBLESHOOTING

SYMPTOM	POSSIBLE CAUSE	REMEDY
Water separator warning system comes on: <ul style="list-style-type: none">• Water separator warning buzzer sounds.	Water is accumulated in the water separator.	Clean the water separator (see page 131). Check the fuel tank and fuel line for water accumulation. If the buzzer sounds again, consult with an authorized Honda outboard motor dealer.
PGM-FI warning system comes on: <ul style="list-style-type: none">• PGM-FI indicator comes on.• PGM-FI warning buzzer sounds intermittently.	PGM-FI warning system is faulty.	Consult with an authorized Honda outboard motor dealer.
ACG warning system comes on: <ul style="list-style-type: none">• ACG indicator comes on.• ACG warning buzzer sounds intermittently.	Battery voltage is too high or low.	Check the battery (see page 68, 135).
	Faulty ACG.	Consult with an authorized Honda outboard motor dealer.

TROUBLESHOOTING

Emergency Gear Shifting (for DBW type)

If the gear cannot be shifted, perform shift operation manually according to the following procedures and return to port at possible engine speed.

1. Set the remote control lever in the NEUTRAL position (see page 22-23).
2. Stop the engine (see page 112).
3. Remove the engine cover (see page 60).
4. Shift gear into neutral by inserting the Phillips screwdriver with the grip of the tool kit (see page 120) into the hole of the shift pivot and moving the shaft.
Grasp the shaft closer to the shift pivot of the inserted Phillips screwdriver.
Operate in a stable posture that makes it easy to apply force.

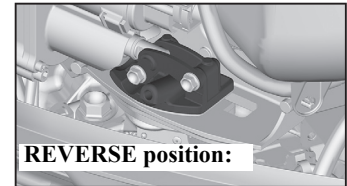
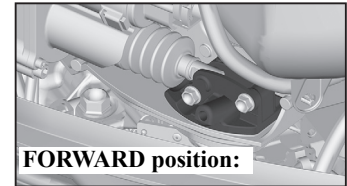
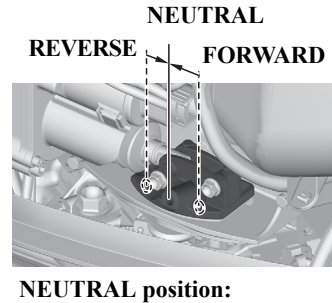
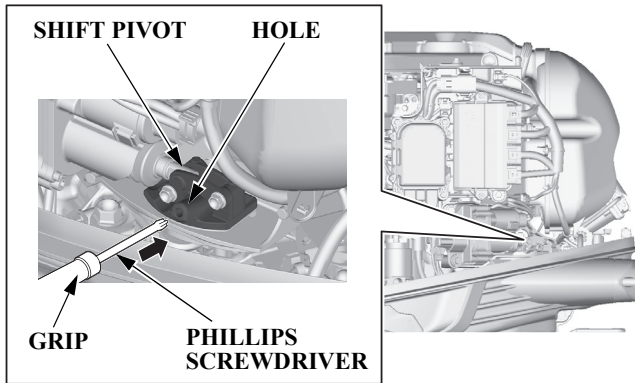

5. Start the engine (see page 70).
6. Shift gear into "F" (Forward) or "R" (Reverse) by moving the shift pivot with the Phillips screwdriver with the grip of the tool kit.

After returning to port, stop the engine and anchor the boat.

16. SPECIFICATIONS

MODEL	BF115J					
Description Code	BBWJ					
Type	LR	LD	XR	XD	XCR	XCD
Overall length	913 mm (35.9 in)					
Overall width	618 mm (24.3 in)					
Overall height	1,688 mm (66.5 in)		1,815 mm (71.5 in)			
Transom height (when transom angle at 12°)	508 mm (20.0 in)		635 mm (25.0 in)			
Dry mass (weight)*	221 kg (487 lbs)	224 kg (494 lbs)	227 kg (500 lbs)	230 kg (507 lbs)		
Rated power	84.6 kW (115 PS)					
Full throttle range	4,500 – 6,000 min ⁻¹ (rpm)					
Engine type	4 stroke DOHC in-line 4-cylinder					
Displacement	2,354 cm ³ (143.6 cu-in)					
Spark plug gap	1.0 – 1.1 mm (0.039 – 0.043 in)					
Remote control steering system	Motor-mounted					
Starter system	Electric starter					
Ignition system	Full transistor battery					
Lubrication system	Trochoid pump pressure lubrication					
Specified oil	Engine: API standard SG, SH, SJ, SL SAE 10W-30 Gear case: API standard GL-4 SAE 90 Hypoid gear oil					

Oil capacity	Engine: Without oil filter replacement: 6.5 L (6.9 US qt, 5.7 Imp qt) With oil filter replacement: 6.7 L (7.1 US qt, 5.9 Imp qt) Gear case: 0.98 L (1.04 US qt, 0.86 Imp qt)
D.C. output	12V – 40A
Cooling system	Water cooling with thermostat
Exhaust system	Water exhaust
Spark plugs	ZFR6K-11 (NGK), KJ20DR-M11 (DENSO)
Fuel pump	High pressure side: Electromagnetic type Low pressure side: Mechanical type
Fuel	Unleaded gasoline (91 research octane, 86 pump octane, or higher)
Gear shift	Dog type (Forward – Neutral – Reverse)
Steering angle	30° right and left
Tilt angle (transom angle at 12°)	Stageless (68°)
Trim angle (transom angle at 12°)	– 4° to 16°

* Without battery cable, with propeller

Honda outboards are power rated in accordance with ISO8665 (propeller shaft output).

SPECIFICATIONS

MODEL	BF135D							
Description Code	BBVJ							
Type	LR	LD	LCR	LCD	XR	XD	XCR	XCD
Overall length	913 mm (35.9 in)							
Overall width	618 mm (24.3 in)							
Overall height	1,688 mm (66.5 in)				1,815 mm (71.5 in)			
Transom height (when transom angle at 12°)	508 mm (20.0 in)				635 mm (25.0 in)			
Dry mass (weight)*	221 kg (487 lbs)	224 kg (494 lbs)	227 kg (500 lbs)	224 kg (494 lbs)	227 kg (500 lbs)	230 kg (507 lbs)		
Rated power	99.3 kW (135 PS)							
Full throttle range	5,000 – 6,000 min ⁻¹ (rpm)							
Engine type	4 stroke DOHC in-line 4-cylinder							
Displacement	2,354 cm ³ (143.6 cu-in)							
Spark plug gap	1.0 – 1.1 mm (0.039 – 0.043 in)							
Remote control steering system	Motor-mounted							
Starter system	Electric starter							
Ignition system	Full transistor battery							
Lubrication system	Trochoid pump pressure lubrication							
Specified oil	Engine: API standard SG, SH, SJ, SL SAE 10W-30 Gear case: API standard GL-4 SAE 90 Hypoid gear oil							

Oil capacity	Engine: Without oil filter replacement: 6.5 L (6.9 US qt, 5.7 Imp qt) With oil filter replacement: 6.7 L (7.1 US qt, 5.9 Imp qt) Gear case: 0.98 L (1.04 US qt, 0.86 Imp qt)
D.C. output	12V – 40A
Cooling system	Water cooling with thermostat
Exhaust system	Water exhaust
Spark plugs	ZFR6K-11 (NGK), KJ20DR-M11 (DENSO)
Fuel pump	High pressure side: Electromagnetic type Low pressure side: Mechanical type
Fuel	Unleaded gasoline (91 research octane, 86 pump octane, or higher)
Gear shift	Dog type (Forward – Neutral – Reverse)
Steering angle	30° right and left
Tilt angle (transom angle at 12°)	Stageless (68°)
Trim angle (transom angle at 12°)	– 4° to 16°

* Without battery cable, with propeller

Honda outboards are power rated in accordance with ISO8665 (propeller shaft output).

SPECIFICATIONS

MODEL	BF150D							
Description Code	BBTJ							
Type	LR	LD	LCR	LCD	XR	XD	XCR	XCD
Overall length	913 mm (35.9 in)							
Overall width	618 mm (24.3 in)							
Overall height	1,688 mm (66.5 in)				1,815 mm (71.5 in)			
Transom height (when transom angle at 12°)	508 mm (20.0 in)				635 mm (25.0 in)			
Dry mass (weight)*	221 kg (487 lbs)	224 kg (494 lbs)	227 kg (500 lbs)	224 kg (494 lbs)	227 kg (500 lbs)	230 kg (507 lbs)		
Rated power	110.3 kW (150 PS)							
Full throttle range	5,000 – 6,000 min ⁻¹ (rpm)							
Engine type	4 stroke DOHC VTEC in-line 4-cylinder							
Displacement	2,354 cm ³ (143.6 cu-in)							
Spark plug gap	1.0 – 1.1 mm (0.039 – 0.043 in)							
Remote control steering system	Motor-mounted							
Starter system	Electric starter							
Ignition system	Full transistor battery							
Lubrication system	Trochoid pump pressure lubrication							
Specified oil	Engine: API standard SG, SH, SJ, SL SAE 10W-30 Gear case: API standard GL-4 SAE 90 Hypoid gear oil							

Oil capacity	Engine: Without oil filter replacement: 6.5 L (6.9 US qt, 5.7 Imp qt) With oil filter replacement: 6.7 L (7.1 US qt, 5.9 Imp qt) Gear case: 0.98 L (1.04 US qt, 0.86 Imp qt)
D.C. output	12V – 40A
Cooling system	Water cooling with thermostat
Exhaust system	Water exhaust
Spark plugs	ZFR6K-11 (NGK), KJ20DR-M11 (DENSO)
Fuel pump	High pressure side: Electromagnetic type Low pressure side: Mechanical type
Fuel	Unleaded gasoline (91 research octane, 86 pump octane, or higher)
Gear shift	Dog type (Forward – Neutral – Reverse)
Steering angle	30° right and left
Tilt angle (transom angle at 12°)	Stageless (68°)
Trim angle (transom angle at 12°)	– 4° to 16°

* Without battery cable, with propeller

Honda outboards are power rated in accordance with ISO8665 (propeller shaft output).

SPECIFICATIONS

Noise and Vibration

MODEL	BF115J	BF135D	BF150D
CONTROL SYSTEM	R (Remote control)	R (Remote control)	R (Remote control)
Sound pressure level at operator's ears (2006/42/EC, ICOMIA 39-94)	80 dB (A)	80 dB (A)	82 dB (A)
----- Uncertainty	3 dB (A)	1 dB (A)	3 dB (A)
Measured sound power level (Reference to EN ISO3744)	90 dB (A)	90 dB (A)	92dB (A)
----- Uncertainty	3 dB (A)	1 dB (A)	3 dB (A)
Vibration level at hand arm (2006/42/EC, ICOMIA 38-94)	–	–	–
----- Uncertainty	–	–	–

Reference to: ICOMIA Standard: as it specifies the engine operating conditions and measurement conditions.

Compass safe distance

MODEL	BF115J	BF135D	BF150D
Compass safe distance (IEC 60945)	400 mm (15.8 in)		

For Drive by Wire (DBW) type only: DBW REMOTE CONTROL BOX, KEY SWITCH PANEL, CONTROL UNIT

17. MAJOR Honda DISTRIBUTOR ADDRESSES

For further information, please contact Honda Customer Information Centre at the following address or telephone number:

For European

AUSTRIA

Honda Motor Europe Ltd

Hondastraße 1
2351 Wiener Neudorf
Tel.: +43 (0)2236 690 0
Fax: +43 (0)2236 690 480
<http://www.honda.at>

✉ HondaPP@honda.co.at

BALTIC STATES (Estonia/Latvia/ Lithuania)

NCG Import Baltics OU

Meistri 12
13517 Tallinn
Harju County Estonia
Tel.: +372 651 7300
Fax: +372 651 7301

✉ info.baltic@ncgimport.com

BELARUS

JV "Scanlink" Ltd.

Montazhnikov lane 4th, 5-16
Minsk 220019
Republic of Belarus
Tel.: +375172349999
Fax: +375172380404

✉ honda@scanlink.by

BELGIUM

Honda Motor Europe Ltd

Doornveld 180-184
1731 Zellik
Tel.: +32 2620 10 00
Fax: +32 2620 10 01
<http://www.honda.be>

✉ bh_pe@honda-eu.com

BULGARIA

Premium Motor Ltd

Andrey Lyapchev Blvd no 34
1797 Sofia
Bulgaria

Tel.: +3592 423 5879
Fax: +3592 423 5879

<http://www.hondamotor.bg>

✉ office@hondamotor.bg

CROATIA

Fred Bobek d.o.o.

HONDA MARINE
Put Gaćezeza 5b
HR 22211 Vodiče
Tel.: 00385 22 444336
Fax.: 00385 22 440500

✉ centrala@honda-croatia.com

CYPRUS

Powerline Products Ltd

Cyprus - Nicosia
Vasilias 18 2232 Latsia
Tel.: 0035799490421

✉ info@powerlinecy.com
<http://www.powerlinecy.com>

CZECH REPUBLIC

BG Technik cs, a.s.

U Zavodiste 251/8
15900 Prague 5 - Velka
Chuchle

Tel.: +420 2 838 70 850
Fax: +420 2 667 111 45

<http://www.honda-stroje.cz>

DENMARK

TIMA A/S

Ryttermarken 10
DK-3520 Farum
Tel.: +45 36 34 25 50
Fax: +45 36 77 16 30
<http://www.tima.dk>

FINLAND

OY Brandt AB.

Tuupakantie 7B
01740 Vantaa
Tel.: +358 207757200
Fax: +358 9 878 5276
<http://www.brandt.fi>

FRANCE

Honda Motor Europe Ltd

Division Produit d'Equipe-
ment
Parc d'activités de Pariest,
Allée du 1er mai

Croissy Beaubourg BP46, 77312
Marne La Vallée Cedex 2

Tel.: 01 60 37 30 00

Fax: 01 60 37 30 86

<http://www.honda.fr>

✉ espace-client@honda-eu.com

GERMANY

Honda Deutschland Niederlassung der Honda Motor Europe Ltd.

Hanauer Landstraße 222-224
D-60314 Frankfurt
Tel.: 01805 20 20 90

Fax: +49 (0)69 83 20 20

<http://www.honda.de>

✉ info@post.honda.de

MAJOR Honda DISTRIBUTOR ADDRESSES

For further information, please contact Honda Customer Information Centre at the following address or telephone number:

For European (continued)

GREECE

Saracakis Brothers S.A.

71 Leoforos Athinon
10173 Athens
Tel.: +30 210 3497809
Fax: +30 210 3467329
<http://www.honda.gr>
✉ info@saracakis.gr

HUNGARY

MP Motor Co., Ltd.

Kamaraerdei ut 3.
2040 Budaors
Tel.: +36 23 444 971
Fax: +36 23 444 972
<http://www.hondakisgepek.hu>
✉ info@hondakisgepek.hu

IRELAND

Two Wheels Ltd

M50 Business Park, Ballymount
Dublin 12
Tel.: +353 1 4381900
Fax: +353 1 4607851
<http://www.hondaireland.ie>
✉ sales@hondaireland.ie

ISRAEL

**Mayer's Cars and Trucks Co.Ltd. -
Honda Division**

Shevach 5, Tel Aviv, 6777936
Israel
+972-3-6953162
✉ OrenBe@mct.co.il

ITALY

Honda Motore Europe Ltd

Via della Cecchignola, 13
00143 Roma
Tel.: +848 846 632
Fax: +39 065 4928 400
<http://www.hondaitalia.com>
✉ info.power@honda-eu.com

NORTH MACEDONIA

Fred Bobek d.o.o.

HONDA MARINE
Put Gačeleza 5b
HR 22211 Vodice
Tel.: 00385 22 444336
Fax: 00385 22 440500
✉ centrala@honda-croatia.com

MALTA

**The Associated Motors
Company Ltd.**

New Street in San Gwakklin Road
Mriehel Bypass, Mriehel QRM17
Tel.: +356 21 498 561
Fax: +356 21 480 150
✉ mgalea@gasanzammit.com

NORWAY

KELLOX

Box 24, N-141
Trollåsveien 36, 1414
Trollåsen, Norway
Mobile: +47 47 80 90 00
Phone: +47 64 97 61 00
<http://kellox.no/>
✉ finn.hoge@kellox.no

POLAND

Aries Power Equipment

Puławska 467
02-844 Warszawa
Tel.: +48 (22) 861 43 01
Fax: +48 (22) 861 43 02
<http://www.ariespower.pl>
<http://www.mojahonda.pl>
✉ info@ariespower.pl

PORTUGAL

**GROW Productos de Forca
Portugal**

Rua Fontes Pereira de Melo, 16
Abrunheira, 2714-506 Sintra
Tel.: +351 211 303 000
Fax: +351 211 303 003
<http://www.grow.com.pt>
✉ geral@grow.com.pt

ROMANIA

Agrisorg SRL

Sacadat Str Principala
Nr 444/A Jud. Bihor
Romania
Tel.: (+4) 0259 458 336
✉ info@agrisorg.com

SERBIA & MONTENEGRO

Fred Bobek d.o.o.

HONDA MARINE
Put Gačeleza 5b
HR 22211 Vodice
Tel.: 00385 22 444336
Fax.: 00385 22 440500
✉ centrala@honda-croatia.com

MAJOR Honda DISTRIBUTOR ADDRESSES

For further information, please contact Honda Customer Information Centre at the following address or telephone number:

For European (continued)

SLOVAK REPUBLIC

Honda Motor Europe Ltd
Slovensko, organizačná zložka
Prievozská 6 821 09 Bratislava
Tel.: +421 2 32131111
Fax: +421 2 32131112
<http://www.honda.sk>

SLOVENIA

Fred Bobek d.o.o.
HONDA MARINE
Put Gaćeleza 5b
HR 22211 Vodice
Tel.: 00385 22 444336
Fax.: 00385 22 440500
✉ centrala@honda-croatia.com

SPAIN & all Provinces

Greens Power Products, S.L.
Polígono Industrial Congost –
Av Ramon Ciurans n°2
08530 La Garriga - Barcelona
Tel.: +34 93 860 50 25
Fax: +34 93 871 81 80
<http://www.hondaencasa.com>

SWEDEN

Honda Motor Europe Ltd filial
Sverige
Box 31002 - Långhusgatan 4
215 86 Malmö
Tel.: +46 (0)40 600 23 00
Fax: +46 (0)40 600 23 19
<http://www.honda.se>
✉ hpesinfo@honda-eu.com

SWITZERLAND

Honda Motor Europe Ltd.
Succursale de Satigny/Genève
Rue de la Bergère 5
1242 Satigny
Tel.: +41 (0)22 989 05 00
Fax: +41 (0)22 989 06 60
<http://www.honda.ch>

TURKEY

Anadolu Motor Uretim Ve
Pazarlama As
Sekerpinar Mah
Albayrak Sok No 4
Cayirova 41420
Kocaeli
Tel.: +90 262 999 23 00
Fax: +90 262 658 94 17
<http://www.anadolumotor.com.tr>
✉ antor@antor.com.tr

UKRAINE

Dnipro Motor LLC
3, Bondarsky Alley,
Kyiv, 04073, Ukraine
Tel.: +380 44 537 25 76
Fax: +380 44 501 54 27
✉ igor.lobunets@honda.ua

UNITED KINGDOM

Honda Motor Europe Ltd
Cain Road
Bracknell
Berkshire
RG12 1 HL
Tel.: +44 (0)845 200 8000
<http://www.honda.co.uk>

18. “UK DECLARATION OF CONFORMITY” CONTENT OUTLINE

1) UK-DECLARATION OF CONFORMITY	
2) THE UNDERSIGNED, (13), REPRESENTING THE MANUFACTURER, HEREWITH DECLARES THAT THE PRODUCT IS IN CONFORMITY WITH THE PROVISIONS OF THE FOLLOWING STATUTORY REQUIREMENTS	
SI 2008 No. 1597 ; SI 2016 No. 1091	
3) REFERENCE TO DESIGNATED STANDARDS: EN 61000-6-1: 2007, EN 55012:2007+A1:2009	
4) DESCRIPTION OF THE MACHINERY	
5) Generic denomination: Outboard engine 6) Function: Propulsion system 7) MAKE: Honda/Tohatsu	
8) TYPE: <input type="text"/>	9) SERIAL NUMBER: <input type="text"/>
10) Manufacturer: Honda Motor Co., Ltd. 2-1-1 Minamiaoyama Minato-ku Tokyo 107-8556 Japan	
11) Authorized representative and able to compile the technical documentation: Honda Motor Europe Ltd Cain Road, Bracknell, Berkshire, RG12 1HL, United Kingdom	
12) SIGNATURE: <input type="text"/>	
13) NAME: <input type="text"/>	16) DATE: <input type="text"/>
14) TITLE: <input type="text"/>	17) PLACE: <input type="text"/>

19. “EC DECLARATION OF CONFORMITY” CONTENT OUTLINE

1) EC-DECLARATION OF CONFORMITY

2) THE UNDERSIGNED, (13), REPRESENTING THE MANUFACTURER, HEREWITH DECLARES THAT THE PRODUCT IS IN CONFORMITY WITH THE PROVISIONS OF THE FOLLOWING EC-DIRECTIVES

2006/42/EC, 2014/30/EU

3) REFERENCE TO HARMONIZED STANDARDS:

EN 61000-6-1: 2007, EN 55012:2007+A1:2009

4) DESCRIPTION OF THE MACHINERY

5) Generic denomination: Outboard engine 6) Function: Propulsion system 7) MAKE: Honda/Tohatsu

8) TYPE:

9) SERIAL NUMBER:

10) Manufacturer:

Honda Motor Co., Ltd.
2-1-1 Minamiaoyama Minato-ku Tokyo 107-8556 Japan

11) Authorized representative and able to compile the technical documentation:

Honda Motor Europe Ltd – Aalst Office
Wijngaardveld 1 (Noord V)
9300 Aalst - Belgium

12) SIGNATURE:

12)

13) NAME:

13)

14) TITLE

15)

16) DATE:

16)

17) PLACE:

17)

“EC DECLARATION OF CONFORMITY” CONTENT OUTLINE

<p>1) DECLARATION CE DE CONFORMITE 2) LE SOUSSIGNÉ, (13), REPRÉSENTANT DU CONSTRUCTEUR, DÉCLARE PAR LA PRÉSENTE QUE LE PRODUIT EST CONFORME AUX DISPOSITIONS DES DIRECTIVES CE SUIVANTES 3) REFERENCE AUX NORMES HARMONISÉES 4) DESCRIPTION DE MACHINE 5) Denomination générique: moteur hors-bord 6) Fonction : Système de propulsion 7) MARQUE 8) TYPE 9) NUMÉRO DI SERIE 10) CONSTRUCTEUR 11) Représentant autorisé et en charge des éditions de documentation techniques 12) SIGNATURE 13) NOM 14) TITRE 15) Directeur Qualité 16) DATE 17) LIEU</p>	français (FRENCH)
<p>1) DICHIARAZIONE DI CONFORMITA' CE 2) IL SOTTOSCRITTO, (13), RAPPRESENTANTE DEL COSTRUTTORE, DICHIARA QUI DI SEGUITO CHE IL PRODOTTO E' CONFORME A QUANTO PREVISTO DALLE SEGUENTI DIRETTIVE COMUNITARIE 3) RIFERIMENTO ALLE NORME ARMONIZZATE 4) DESCRIZIONE DELLA MACCHINA 5) Denominazione generica: MOTORE FUORIBORDO 6) Funzione : Sistema di propulsione 7) MARCA 8) TIPO 9) NUMERO DI SERIE 10) FABBRICANTE 11) Rappresentante autorizzato e competente per la compilazione della documentazione tecnica 12) FIRMA 13) NOME 14) TITOLO 15) DIRETTORE DELLA QUALITA' 16) ADDI' 17) LUOGO</p>	italiano (ITALIAN)
<p>1) EG-KONFORMITÄTSERKLÄUNG 2) DER UNTERZEICHNER, (13), DER DEN HERSTELLER VERTRITT, ERKLÄRT HIERMIT, DAB DAS PRODUKT IN ÜBEREINSTIMMUNG MIT DEN BESTIMMUNGEN DER NACHSTEHENDEN EG-RICHTLINIEN IST 3) VERWEIS AUF HARMONISIERTE NORMEN 4) BESCHREIBUNG DER MASCHINE 5) Allgemeine Bezeichnung : Außenbordmotor 6) Funktion : Antriebsart 7) FABRIKAT 8) TYP 9) SERIEN NUMMER 10) HERSTELLER 11) Bevollmächtigter und in der Position, die technische Dokumentation zu erstellen 12) UNTERSCHIFT 13) NAME 14) TITEL 15) Qualitätssicherung 16) DATUM 17) ORT</p>	deutsch (GERMAN)
<p>1) EG-VERKLARING VAN OVEREENSTEMMING 2) ONDERGETEKENDE, (13), VERTEGENWOORDIGER VAN DE FABRIKANT, VERKLAART HIERMEE DAT HET PRODUCT VOLDOET AAN DE BEPALINGEN VAN DE VOLGENDE EG-RICHTLIJNEN 3) REFERENTIE NAAR GEHARMONISEERDE NORMEN 4) BESCHRIJVING VAN DE MACHINE 5) Algemene benaming : buitenboordmotor 6) Functie : Aandrijfsysteem 7) FABRIKAT 8) TYPE 9) SERIEN UMMER 10) FABRIKANT 11) Gemachtigde van de fabrikant en in staat om de technische documentatie samen te stellen 12) HANDTEKENING 13) NAAM 14) TITEL 15) Directeur Kwaliteitszorg 16) DATUM 17) PLAATS</p>	nederlands (DUTCH)
<p>1) ΕΚ-ΔΗΛΩΣΗ ΕΝΑΡΜΟΝΙΣΗΣ 2) Ο ΥΠΟΓΡΑΦΩΝ, (13), ΕΚΠΡΟΣΩΠΟΝΤΑΣ ΤΟΝ ΚΑΤΑΣΚΕΥΑΣΤΗ, ΔΙΑ ΤΟΥ ΠΑΡΟΝΤΟΣ ΔΗΛΩΝΕΙ ΟΤΙ ΤΟ ΠΡΟΪΟΝ ΒΡΙΣΚΕΤΑΙ ΣΕ ΕΝΑΡΜΟΝΙΣΗ ΜΕ ΤΙΣ ΠΡΟΒΛ ΕΦΕΙΣ ΤΩΝ ΚΑΤΩΘΙ ΟΔΗΓΙΩΝ ΤΗΣ ΕΕ 3) ΠΑΡΑΠΟΜΠΗ ΣΤΑ ΕΝΑΡΜΟΝΙΣΜΕΝΑ ΠΡΟΤΥΠΑ 4) ΠΕΡΙΓΡΑΦΗ ΜΗΧΑΝΗΜΑΤΟΣ 5) Γενική ονομασία : Εξωλέμβια μηχανή 6) Λειτουργία : Σύστημα Πρόωσης 7) ΕΡΓΟΣΤΑΣΙΟ ΚΑΤΑΣΚΕΥΗΣ 8) ΤΥΠΟΣ 9) ΑΡΙΘΜΟΣ ΣΕΙΡΑΣ 10) ΚΑΤΑΣΚΕΥΑΣΤΗΣ 11) Εξουσιοδοτημένος αντιπρόσωπος και είναι σε θέση να καταρτίσει τον τεχνικό φάκελο 12) ΥΠΟΓΡΑΦΗ 13) ΟΝΟΜΑ 14) ΤΙΤΛΟΣ 15) Υπεύθυνος Ποιότητας 16) ΗΜΕΡΟΜΗΝΙΑ 17) ΤΟΠΟΣ</p>	Ελληνικά (GREEK)
<p>1) EF OVERENSSTEMMELSESEKTLÆRING 2) UNDERTEGNEDE, (13), DER REPRÆSENTERER FABRIKANTEN, ERKLÆRER HERMED AT PRODUKTET ER I OVERENSSTEMMELSE MED BESTEMMELSERNE I FØLGE EF DIREKTIVERNE 3) REFERENCE TIL HARMONISERED E STANDARDER 4) BESKRIVELSE AF MASKINEN 5) FÆLLESBETEGNELSE : Utenbordsmotor 6) ANVENDELSE : Fremdrivningssystem 7) FABRIKANT 8) TYPE 9) SERIEN UMMER 10) FABRIKANT 11) AUTORISERET REPRÆSENTANT OG I STAND TIL AT UDARBEJDE DEN TEKNISKE DOKUMENTATION 12) SIGNATURE 13) NAVN 14) TITEL 15) Kvalitets Leder 16) DATO 17) STED</p>	dansk (DANISH)

“EC DECLARATION OF CONFORMITY” CONTENT OUTLINE

<p>1) DECLARACIÓN DE CONFORMIDAD 2) EL ABAJO FIRMANTE, (13), EN REPRESENTACIÓN DE FABRICANTE, DECLARA QUE EL PRODUCTO ES CONFORME CON LAS DISPOSICIONES DE LAS SIGUIENTES DIRECTIVAS CE 3) REFERENCIA A ESTÁNDARES ARMONIZADOS 4) DESCRIPCIÓN DE LA MAQUINARIA 5) Denominación genérica : Motor fueraborda 6) Función : Sistema de propulsión 7) MARCA 8) TIPO 9) NUMERO DE SERIE 10) FABRICANTE 11) Representante autorizado que puede compilar el expediente técnico 12) FIRMA 13) NOMBRE 14) CARGO 15) Director de calidad 16) FECHA 17) LUGAR</p>	español (SPANISH)
<p>1)DECLARAÇÃO CE DE CONFORMIDADE 2) O ABAIXO ASSINADO, (13), EM REPRESENTAÇÃO DO FABRICANTE, PELA PRESENTE DECLARA QUE O PRODUTO ESTÁ EM CONFORMIDADE COM O ESTABELECIDO NAS SEGUINTE DIRECTIVAS COMUNITÁRIAS 3) REFERÊNCIA AS NORMAS HARMONIZADAS 4) DESCRIÇÃO DA MÁQUINA 5) Denominação genérica : Motor fora de borda 6) Função : Sistema propulsor 7) MARCA 8) TIPO 9) NÚMERO DE SÉRIE 10) FABRICANTE 11) Mandatário com capacidade para compilar documentação técnica 12) ASSINATURA 13) NOME 14) TÍTULO 15) Director de Qualidade 16) DATA 17) LOCAL</p>	português (PORTUGUESE)
<p>1) EY-VAATIMUSTENMUKAISUUSVAKUUTUS 2) ALLEKIRJOITANUT, (13), JOKA EDUSTAA VALMISTAJAA, VAKUUTTAA TÄTEN, ETTÄ TUOTE ON SEURAAVIEN EU-DIREKTIIVIAN VAATIMUSTEN MUKAINEN 3) VITTAUS YHTEISIIN STANDARDEIHIN 4) KUVAUS LAITTEESTA 5) Yleisarvomäärä : Peramoottori 6) Toiminto : Työntöjärjestelmä 7) MERKKI 8) MALLI 9) SARJANUMERO 10) VALMISTAJA 11) Valmistajan edustaja ja teknisten dokumenttien laatija 12) ALLEKIRJOITUS 13) NIMI 14) TITTELI 15) Laatupäällikkö 16) PÄIVÄMÄÄRÄ 17) PAIKKA</p>	suomi / suomen kieli (FINNISH)
<p>1) ЕО-ДЕКЛАРАЦИЯ ЗА СЪОТВЕТСТВИЕ 2) ДОЛУ ПОДШИСАЛИЯТ СЕ (13), ПРЕДСТАВЛЯВАЩ ДИСТРИБУТОРА, ДЕКЛАРИРА, ЧЕ ПРОДУКТА СЪОТВЕТСТВА НА ИЗСКВАНИЯТА НА СЛЕДНИТЕ ЕВРОПЕЙСКИ ДИРЕКТИВИ 3) СЪОТВЕТСТВИЕ С ХАРМОНИЗИРАНИТЕ СТАНДАРТИ 4) ОПИСАНИЕ НА АРТИКУЛА 5) Общо наименование : ИЗВЪН БОРДОВИ ДВИГАТЕЛ 6) Функция : Задвижваща система 7) МАРКА 8) ТИП 9) СЕРИЕН НОМЕР 10) ПРОИЗВОДИТЕЛ 11) Упълномощен представител и отговорник за съставяне на техническа документация 12) ПОДПИС 13) ИМЕ 14) ТИТЛА 15) МЕНИДЖЪР НА КАЧЕСТВОТО 16) ДАТА 17) МЯСТО</p>	български (BULGARIAN)
<p>1) EG-FÖRSÄKRAN OM ÖVERENSSTÄMMELSE 2) UNDERTECKNAD, (13), REPRESENTERANDE TILLVERKARE, FÖRSÄKRAR HÄRMED ATT PRODUKTEN ÖVERENSSTÄMMER MED BESTÄMMELSENA I FÖLJANDE EG-DIREKTIVE 3) REFERERANDE TILL HARMONISERADE STANDARDER 4) BESKRIVNING AV UTRUSTNINGEN 5) Allmän benämning : Utomborotsmotor 6) Funktion : Framdrivningssystem 7) MERKKI 8) TYYPBETECKNING 9) SERIENUMER 10) TILLVERKARE 11) Auktoriserad representant och ska kunna sammanställa teknisk dokumentationen. 12) SIGNATUR 13) NAMN 14) TITEL 15) Kvalitetschef 16) DATUM 17) ORT</p>	svenska (SWEDISH)
<p>1) DEKLARACJA ZGODNOŚCI WE 2) NIŻEJ PODPISANY (13), REPREZENTUJĄCY PRODUCENTA, DEKLARUJE Z CAŁĄ ODPOWIEDZIALNOŚCIĄ, ŻE PRODUKT SPEŁNIA WYMAGANIA ZAWARTE W NASTĘPUJĄCYCH DYREKTYWACH UNIJNYCH 3) ZASTOSOWANE NORMY ZHARMONIZOWANE 4) OPIS URZĄDZENIA 5) Ogólne określenie : Silnik zaburtowy 6) Funkcja : Układ napędowy 7) MARKA 8) TYP 9) NUMERY SERYJNE 10) PRODUCENT 11) Upoważniony Przedstawiciel oraz osoba upoważniona do przygotowania dokumentacji technicznej 12) PODPIS 13) NAZWISKO 14) TYTUŁ 15) Menadżer Jakości 16) DATA 17) MIEJSCE</p>	polski (POLISH)

“EC DECLARATION OF CONFORMITY” CONTENT OUTLINE

<p>1)MEGFELELŐSEGI NYILATKOZAT 2)ALULÍROTT (13), MINT A GYÁRTÓ KÉPVISELŐJE NYILATKOZIK, HOGY AZ ALABBI TERMÉK MINDENBEN MEGFELEL A KÖVETKEZŐ EC ELŐÍRÁSOK RENDELKEZÉSEINEK: 98/37/EC, 89/336/EEC-93/68/EC: 3)ÖSSZHANGBAN A KÖV. SZABVÁNYOKKAL 4)A GÉP LEÍRÁSA 5) Általános megnevezés : KÜLSŐ CSÓNAKMOTOR 6) Funkció : Hajtás rendszer 7) GYÁRTÓTTA 8) TÍPUS 9) SORSZÁM 10) GYÁRTÓ 11) Meghatalmazott képviselője és képes összeállítani a műszaki dokumentációt. 12) ALÁÍRÁS 13) NÉV 14) BEOSZTÁS 15) MINŐSÉGI IGAZGATÓ 16) KELTEZÉS DÁTUMA 17) KELTEZÉS HELYE</p>	magyar (HUNGARIAN)
<p>1)Prohlášení o shodě 2) ZÁSTUPCE VÝROBCE, (13), SVÝM PODPÍSEM POTVRZUJE, ŽE DANÝ VÝROBEK JE V SOULADU S NÁSLEDUJÍCÍMI SMĚRNICEMI A NORMAMI EVROPSKÉHO SPOLEČENSTVÍ: 3) ODKAZ NA HARMONIZOVANÉ NORMY: 4) POPIS VÝROBKU 5) Všeobecné označení : ZÁVĚSNÝ LODNÍ MOTOR 6) Funkce : Pohonný systém 7) ZNAČKA: 8) TYP: 9) VÝROBNÍ ČÍSLO: 10) VÝROBCE: 11) Zplnomocněný zástupce a osoba pověřená kompletací technické dokumentace 12) PODPIS: 13) JMÉNO: 14) POZICE 15) Manažer kvality 16) DATUM: 17) MÍSTO:</p>	čeština (CZECH)
<p>1) ES VYHLÁSENIE O ZHODE 2) DOLUPODPÍSANÝ, (13), ZASTUPUJÚCI VÝROBCU, TÝMTO DEKLARUJE, ŽE PRODUKT JE V SÚLADE S USTANOVENIAMÍ NASLEDOVNÝCH SMERNÍC ES 3) REFERENCIA K HARMONIZOVANÝM ŠTANDARDOM 4) IDENTIFIKÁCIA STROJOV 5) Druhové označenie : ZÁVESNÝ LODNÝ MOTOR 6) Funkcia : Systém pohonu 7) VÝROBCA/ZNAČKA 8) TYP 9) SÉRIOVÉ ČÍSLO 10) VÝROBCA 11) Autorizovaný zástupca schopný zostaviť technickú dokumentáciu 12) PODPIS 13) MENO 14) POZÍCIA 15) MANAŽÉR KVALITY 16) DÁTUM 17) MIESTO</p>	slovenčina (SLOVAK)
<p>1) EF SAMSVARSÆRKLERING 2) UNDERTEGNEDE, (13), SOM REPRÆSENTERER FABRIKANTEN, ERKLÆRER HERVED AT PRODUKTET ER I OVERENSSTEMMELSE MED BESTEMMELSENE I FØLGENDE EU DIREKTIV 3) REFERANSER TIL HARMONISEREDE STANDARDER 4) BESKRIVELSE AV MASKINEN 5) Felles benevnelse : Utenbordsmotor 6) Funksjon : Fremdrifts system 7) FABRIKANT 8) TYPE 9) SERIE NUMMER 10) FABRIKANT 11) Autorisert representant og i stand til å utarbeide den tekniske dokumentasjonen 12) SIGNATUR 13) NAVN 14) TITTEL 15) Kvalitetssjef 16) DATO 17) STED</p>	norsk (NORWEGIAN)
<p>1) DECLARATIE DE CONFORMITATE. 2) SUBSEM NATUL, (13), REPREZENTAND PE PRODUCATOR, DECLAR PRIN PREZE NTA CA PRODUSUL ESTE IN CONFORMITATE CU PREVEDERILE URMATOARELOR DIRECTIVE CE 3) REFERIRE LA STANDARDELE ARMONIZATE: 4) DESCRIEREA ECHIPAMENTULUI 5) Denumire generica : MOTOR IN AFARA BORDULUI (EXTERN) 6) Domeniu de utilizare : Sistem de propulsie 7) MARCA 8) TIPUL 9) NUMAR DE SERIE 10) PRODUCATOR 11) Reprezentant autorizat și abilitat să realizeze documentație tehnică 12) SEMNATURA 13) NUME 14) TITLUL 15) DIRECTOR DE CALITATE 16) DATA 17) LOCATIE</p>	română (ROMANIAN)
<p>1)EÜ VASTAVUSDEKLARATSIOON 2)ALLAKIRJUTANU, (13), ESINDADES TOOTJAT, DEKLAREERIB SIINKOHAL, ET TOODE ON VASTAVUSES JÄRGMISTE EC DIREKTIVIDE SÄTETEGA 3)VIDE ÜHTLUSTATUD STANDARDITELE: 4)MEHHAANISMI KIRJELDUS 5)Üldnimetus : Pardaväliline mootor 6) Funktsioon : Tõukurüstestem 7)VALMISTAJA: 8)TÜÜP: 9)SEERIANUMBER: 10)TOOTJA: 11) Volitatud esindaja, kes on pädev täitma tehnilist dokumentatsiooni 12)ALLKIRI: 13)NIMI: 14)AMET 15)Kvaliteedijuht 16)KUUPÄEV: 17)KOHT:</p>	eeesti (ESTONIAN)

“EC DECLARATION OF CONFORMITY” CONTENT OUTLINE

<p>1) EK ATBILSTĪBAS DEKLARĀCIJA 2) ZEMĀK MINĒTAIS, (13), KĀ RAŽOTĀJA PĀRSTĀVIS AR ŠO APSTIPRINA, KA ŠIS PRODUKTS PILNĪBA ATBILST VISIEM STANDARTIEM, KĀS ATRUNĀTI SEKOJOŠAJĀS EC-DIREKTĪVĀS</p> <p>3) Atsaucoties uz saskaņotajiem standartiem 4) Iekārtas apraksts 5) Vispārējais nosaukums : Piekārināmais laivas dzinējs 6) Funkcija : Virzošā spēka sistēma 7) Preču zīme 8) Tips 9) Sērijas numurs 10) Izgatavotājs 11) Autorizētais pārstāvis, kas spēj sastādīt tehnisko dokumentāciju 12) Paraksts 13) Vārds, Uzvārds 14) Tituls 15) Kvalitātes vadītājs 16) Datums 17) Vieta</p>	latviešu (LATVIAN)
<p>1) EB ATITIKTIES DEKLARĀCIJA 2) ŽEMIAUI PASIRAŠES, (13), ATSTOVAUJANTIS GAMINTOJĀ DEKLARUOJA KAD PRODUKTAS ATITINKA REIKALAVĪMUS PAGAL ŠĪAS EB DIREKTĪVAS.</p> <p>3) NUORODA Į HARMONIZUOTUS STANDARTUS. 4) MAŠINOS APRAŠYMAS.</p> <p>5) Bendras pavadinimas : PAKABINAMAS VARIKLIS 6) Funkcija : Varomasis būdas 7) MARKĖ. 8) TIPAS 9) SERIJINIS NUMERIS. 10) GAMINTOJAS. 11) Įgaliotasis atstovas ir galintis sudaryti techninę dokumentaciją 12) PARAŠAS. 13) V. PAVARDĖ 14) PAREIGOS 15) KOKYBĖS VADYBININKAS. 16) DATA. 17) VIETA</p>	lietuvių kalba (LITHUANIAN)
<p>1) ES-DEKLARACIJA O USTREZNOSTI 2) PODPISANI (13), PREDSTAVNIK PROIZVAJALCA, IZJAVLJAM DA IZDELKI USTREZAJO NASLEDNJIM DEKLARACIJAM</p> <p>3) SKLADNOST Z NASLEDNJIMI STANDARDI 4) OPIS IZDELKOV</p> <p>5) Vrsta stroja : Izvenkrmni motorji 6) Funkcija : Pogonski sistem 7) PROIZVAJA 8) TIP 9) SERIJSKA ŠTEVILKA 10) PROIZVAJALEC 11) Pooblaščeni predstavnik ki lahko predloži tehnično dokumentacijo 12) PODPIS 13) IME 14) FUNKCIJA 15) Direktor presoje 16) DATUM 17) KRAJ</p>	slovenščina (SLOVENIAN)
<p>1) EB-YFIRLYSING 2) UNDIRRITADUR HR. (13) LYSI YFIR FYRIR HÖND FRAMLEIÐANDA AÐ VARAN UPPFYLLIR EFTIRFARANDI EC-TILSKIPANIR 3) TILVÍSUN UM HEILDARSTAÐAL 4) LÝSING Á VÉLBÚNAÐI</p> <p>5) Flokkur : Utanborðsmótorar 6) Virkni : knúningsafl kerfi 7) FRAMLEIÐSLA 8) GERÐ 9) SERÍAL NÚMER 10) FRAMLEIÐANDI 11) Löggildir aðilar og fær um að taka saman tækniskjölin 12) UNDIRSKRIFT 13) NAFN 14) TITILL 15) Skráningarstjóri 16) DAGSETNING 17) STAÐUR</p>	Íslenska (ICELANDIC)
<p>1) AT UYGUNLUK BEYANI 2) AŞAĖIDA İMZASI BULUNAN VE İMALATÇININ YETKİLİ TEMSİLCİSİ OLAN (13) ÜRÜNÜN ŞU AT YÖNETMELİKLERİNİN HÜKÜMLERİNE UYGUN OLDUĖUNU BEYAN EDER.</p> <p>3) UYUMLAŞTIRILMIŞ STANDARTLARA ATIF 4) MAKİNANIN TARIFI</p> <p>5) Flokkur : Diştan takma motor 6) Virkni : tahrik sistemi 7) MARKA 8) TİP 9) SERİ NUMARASI 10) İMALATÇI 11) Teknik dosyayı hazırlamakla yetkili olan Toplulukta yerleşik yetkili temsilci 12) İMZA 13) ADI 14) ÜNVANI 15) Homologasyon Yöneticisi 16) TARİH 17) YER</p>	Türk (TURKISH)
<p>1)EK-IZJAVA O SUKLADNOSTI 2)POTPIŠANI (13), PREDSTAVNIK PROIZVOĐAČA, IZJAVLJUJE DA JE PROIZVOD U SUKLADNOSTI S ODREDBAMA SLJEDEĆEG EK PROPISA</p> <p>3)REFERENCA NA USKLAĐENE NORME 4)OPIS STROJA</p> <p>5)Opća vrijednost : Vanbrodski motor 6)Funkcionalnost : Pogonski sustav 7)IZRADIO 8)TIP 9)SERIJSKI BROJ 10)PROIZVOĐAČ 11) Ovlašteni predstavnik i osoba za sastavljanje tehničke dokumentacije 12) POTPIS 13) IME 14) TITULA 15) Upravitelj homologacije 16) DATUM 17) MJESTO</p>	hrvatski (CROATIAN)

20. INDEX

A		
ACG Fuse		
Replacement	139	
ACG Indicator/Buzzer		
Function	36	
Operation	105	
Anode		
Function	44	
Operation	111	
B		
Battery		
Cleaning	136	
Connections	53	
Fluid Level Inspection	68	
Inspection	135	
Storage	145	
Break-in Procedure	83	
C		
Cleaning and Flushing	118	
Component Identification	12	
Control and Feature Identification		
Codes	2	
Controls and Features	22	
Cooling Water		
Check Hole	45	
Intake Port	45	
Cruising	89	
D		
Disposal	147	
E		
“EC DECLARATION OF CONFORMITY” Content		
Outline	159	
Emergency Stop		
Switch	42	
Switch Lanyard/Clip	42	
Switch Spare Clip	43, 120	
EMISSION CONTROL SYSTEM	134	
Engine		
Cover		
Latch	45	
Removal/Installation	60	
Oil		
Level Inspection	62	
Refilling	62	
Storage	144	
Protection System	105	
ACG Warning System	105	
Anodes	111	
Oil Pressure Warning System	105	
Overheat Warning System ..	105	
Over-rev Limiter	111	
PGM-FI Warning System ...	105	
Water Contamination Warning System	105	
Serial Number	4	
F		
Fast Idle		
Button	34	
Lever	34	
Frame Serial Number	4	
Fuel		
Filter	131	
Inspection	132	
Replacement	133	
Level	63	
Line		
Connection	59	
Disconnection	116	
Priming	70	
Storage	143	
Fuse Replacement	137	
G		
Gasoline Containing Alcohol	64	
Gear		
Shifting	84, 85, 86, 87, 88	

H	NMEA Interface Coupler..... 46	Operation..... 89
Honda Smart Key29		Pre-operation Checks 60
I	O	Battery..... 68
Ignition Switch28	Oil Pressure Indicator/Buzzer	Engine Oil 61
Inspect After Operating 141	Function 36	Fuel 63
Installation	Operation 105	Other Checks..... 69
Height50	Operating Hour Notification	Spare Parts 69
Location.....50	System 46	Propeller and Cotter Pin
Outboard Motor51	Operation 83	Inspection..... 65
	Gear Shifting..... 84, 85	Remote Control Lever
L	Outboard Motor	Friction..... 66
Lubrication 129	Angle Inspection..... 52	Water Separator 67
	Installation 51	Propeller
M	Storage Position..... 146	Inspection..... 65
Maintenance 119	Overheat Indicator/Buzzer	Replacement..... 140
Maintenance Schedule..... 121	Function 37	Selection..... 59
Major Honda Distributor	Operation 105	Propeller Shaft
Addresses..... 155	Over-rev Limiter 110	Rotating Direction..... 3
Manual	P	R
Relief Valve	PGM-FI Indicator/Buzzer	Remote Control
Function..... 41	Function 35	Box
Operation..... 103	Operation 105	Identification..... 18, 19
Moorage..... 101	Power Tilt Switch	Installation Location 58
Multiple Outboard Motors..... 111	Function 40	Cable Length..... 58
	Operation 102	Installation..... 55
N	Power Trim/Tilt Switch	
Neutral Release Lever27	Function 38	

INDEX

Lever			
Friction Adjustment.....	66		
Function.....	22, 23, 24, 25, 26		
Types	3		
S			
Safety			
Carbon Monoxide Poisoning			
Hazard	9		
Information.....	8		
Label Locations	10		
Operator Responsibility.....	8		
Shallow Water Operation	111		
Spare Emergency Stop Switch			
Clip	43, 120		
Spark Plugs	124		
Specifications	151		
Starting the Engine			
D1, D2 types.....	70		
R1 type	75		
R2, R3 types	78		
Stopping the Engine			
Emergency.....	112		
Normal Stop	112, 114		
Storage.....	143		
Submerged Outboard Motor			
Servicing.....	141		
Switch Panel	20		
		T	
		Tachometer	46
		Tilt Lock Lever	44
		Tilting the Outboard Motor Remote	
		Control Type.....	99
		Tool Kit and Owner's Manual	120
		Trailing	117
		Transom Height	49
		Transporting.....	116
		Trim Meter	
		Function	40
		Operation	98
		Trim Tab	
		Adjustment.....	104
		Function	44
		Trimming the Outboard Motor	95
		TRL (Trolling) Control Switch	
		Function	41
		Operation	92
		Panel	41
		Remote Control Box.....	41
		Troubleshooting	
		Warning System Comes On....	148
		U	
		“UK DECLARATION OF	
		CONFORMITY” Content	
		Outline	158
		V	
		Vapor Separator Draining	143
		W	
		Water Separator	
		Inspection.....	67
		Water Separator Buzzer	37

MEMO

MEMO

HONDA

32ZVT600
00X32-ZVT-6000



英 (AB) 0000.00AA.AA
Printed in Japan