

## INTRODUCTION

Thank you for purchasing a Honda grass/weed trimmer.

This manual covers the operation and maintenance of the Honda GRASS/WEED TRIMMER UMK450T.

Honda Motor Co., Ltd. reserves the right to make changes at any time without notice and without incurring any obligation.

No part of this publication may be reproduced without written permission.

This manual should be considered a permanent part of the grass/weed trimmer and should remain with it if it is resold.

Pay special attention to statements preceded by the following words;

**▲WARNING** Indicates a strong possibility of severe personal injury or death if instructions are not followed.

**CAUTION:** Indicates a possibility of personal injury or equipment damage if instructions are not followed.

**NOTE:** Gives helpful information.

If a problem should arise, or if you have any questions about the grass/weed trimmer, consult an authorized Honda dealer.

Honda grass/weed trimmers are designed to give safe and dependable service if operated according to instructions.

**▲WARNING**  
**Operating a grass/weed trimmer requires special effort to ensure the safety of the operator and the safety of others. Read and understand this Owner's Manual before operating the grass/weed trimmer; failure to do so could result in personal injury or equipment damage.**

Honda Motor Co., Ltd. 2021, All Rights Reserved

## CONTENTS

---

1. SAFETY INSTRUCTIONS.....	3
2. SAFETY LABEL LOCATIONS.....	14
3. COMPONENT IDENTIFICATION.....	15
4. CONTROLS .....	17
5. PRE-OPERATION CHECKS .....	21
6. STARTING THE ENGINE.....	37
7. TRIMMING OPERATION.....	41
8. STOPPING THE ENGINE.....	45
9. MAINTENANCE.....	46
10. TRANSPORTING .....	63
11. STORAGE.....	64
12. TROUBLESHOOTING.....	66
13. SPECIFICATIONS.....	67

# 1. SAFETY INSTRUCTIONS

## ▲WARNING

### To ensure safe operation

For your safety and safety of others, pay special attention to these precautions:



- Honda grass/weed trimmer is designed to give safe and dependable service if operated according to instructions. Read and understand the Owner's Manual before operating the grass/weed trimmer. Failure to do so could result in personal injury or equipment damage.

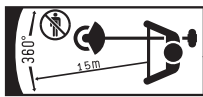

- Keep all persons and pets away from the grass/weed trimmer operating area.
- To prevent accidental contacts with the wheeling cutting attachment or thrown objects from the wheeling cutting attachment, keep people and pets at least 15 m away from the grass/weed trimmer when it is in use.



- Wear ear muffs/ear plugs eye protection, helmet and other protective devices to protect your ears, your eyes and body from noise and all objects (gravel, glass, wire, etc.) thrown by the wheeling cutting attachment.

**▲WARNING**

**To ensure safe operation**

**Operator Responsibility**

- Never operate the grass/weed trimmer when tired, ill or under influence of alcohol or other drugs.
- Any part from the machine is a potential source of danger if the machine is used in abnormal conditions or if the maintenance is not done correctly.
- Read the owner's manual carefully. Be familiar with the controls and their proper use of the grass/weed trimmer. Know how to stop the engine rapidly.
- Use the grass/weed trimmer for the purpose it is intended for, that is trimming.  
Any other use could be dangerous or damage the grass/weed trimmer.  
Do not use the grass/weed trimmer as a pruning hook.
- Never allow children or people unfamiliar with this owner's manual to use the grass/weed trimmer. Local regulations may restrict the age of the operator.
- If you lend or resell your grass/weed trimmer to a third person, instruct him or her with how to handle the product and alert him or her to read the Owner's Manual carefully before operation.
- Never operate the grass/weed trimmer while:
  - people, especially children or pets are nearby.
  - user is fatigued or under medication, or has swallowed substances known to affect judgement or reactions.
- Keep people and pets at least 15 m away from the operator during operation. Note that an assistant to the operator should work at least 15 m away from the operator, too. We recommend to decide the engine stop signal and other signals between the operator and assistant, and use them for safety during operation.
- Keep in mind that the operator or user is responsible for accidents or hazards occurring to other people or their property.

**▲WARNING**

**To ensure safe operation**

**Operator Responsibility**

- While operating the grass/weed trimmer, always wear following protective clothing and protective devices.
  - Protective clothing
    - Wear adequate clothes with long sleeves and long pants. The clothes must fit your body and button up or zip up the clothes securely. Do not leave the sleeves and bottom of the shirt/jacket loose.
    - Wear the arm covers, too.
    - Do not wear the clothes with the tapes, laces and/or ribbons, loose clothes, necktie, necklace, etc. during operation. They can be caught in the grass/weed trimmer or on the weed causing injury.
    - Bind your hair if it is long, and do not let your hair below your shoulder.
  - Protective devices
    - \* Goggles
      - Wear the goggles or other eye protection to protect your eyes from the debris that is thrown by the wheeling cutting attachment.
    - \* Helmet
      - Wear the helmet to protect your head from the overhead branches and the falling contaminated material.
    - \* Face shield
      - Wear face shield to protect your face from the debris thrown by the wheeling cutting attachment.
    - \* Ear muffs/ear plugs
      - Wear the ear muff, ear plugs or other hearing protection to protect your ears from the noise.
    - \* Gloves
      - Wear the gloves to protect your hands.

**▲WARNING**

**To ensure safe operation**

**Operator Responsibility**

**\* Safety boots**

Wear the safety boots with the non-slip sole and toe protector to protect your feet from the flying debris.

Do not operate the equipment when barefoot or wearing open sandals.

Wear the leg protectors as well.

**\* Dust mask**

We recommend that you wear the dust mask if you suffer from the allergic rhinitis, e.g. pollinosis, etc. The dust mask is available at a pharmacy and it is helpful for reducing the amount of pollens you breathe.

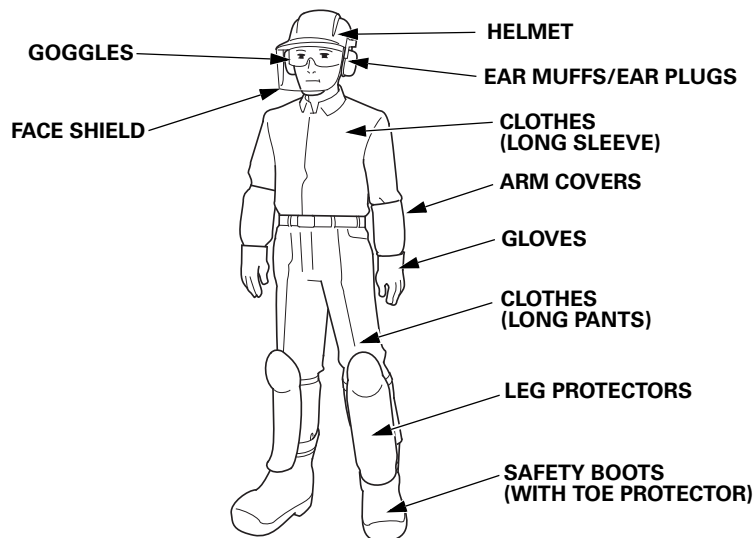

- Before each use, visually inspect the grass/weed trimmer including a cutting attachment for any damage and looseness of fastening part.
- Avoid operating the grass/weed trimmer at night or in a bad weather of poor visibility, because there is much possibility of accident.
- Walk, never run during operation.
- Avoid operating the grass/weed trimmer on a steep slope. The steep slope is very slippery, so you can slip down.

**▲WARNING****To ensure safe operation****Operator Responsibility**

- Do not operate the grass/weed trimmer with the grass deflector, labels, and other parts removed.  
Note that the grass deflector is provided for protection of the operator from the debris that are thrown from the wheeling cutting attachment. Never operate the grass/weed trimmer with the grass deflector removed or before installing the grass deflector in the proper position securely.
- Do not mount an incorrect part and do not tamper with the grass/weed trimmer as it can result in personal injury and/or equipment damage. Use the cutting attachment that is designated for your model and application.
- Before cranking the engine, be sure to check the cutting attachment cannot come into contact with the ground or any obstruction. Failure to do so may result in losing control of the grass/weed trimmer.
- Start the engine carefully according to instructions and with hands and feet well away from the cutting attachment.
- Start the grass/weed trimmer on a level surface, free of high grass or obstacle.
- Do not raise the cutting attachment above your knee height during operation. You can be hit by the debris thrown by the wheeling cutting attachment in your eyes and face causing injury.
- Never carry the grass/weed trimmer while the cutting attachment is turning. Before you carry the grass/weed trimmer, be sure to stop the engine and confirm the cutting attachment stops its turning.

**▲WARNING****To ensure safe operation****Operator Responsibility**

- Stop the engine with the engine switch to the OFF position in the following cases:
  - Before any operation around the cutting attachment.
  - Before checking, cleaning or working on the grass/weed trimmer.
  - After striking a foreign object. Inspect the grass/weed trimmer for damage and make repairs before restarting and operating the grass/weed trimmer again.
  - If grass/weed trimmer starts to vibrate abnormally. Inspect immediately the cause of the vibration and perform the necessary repair.
  - Whenever you leave the grass/weed trimmer unattended.
  - Before refueling.
  - When any person or pet is approaching.
  - Shut off the engine immediately when the grass/weed trimmer shows abnormal vibration suddenly. Sudden vibration can suggest the damaged rotating parts or loose fasteners. Examine the cause of the problem, and do not start the engine before repair is made.
  - When wires catch on the wheeling cutting attachment and flap around. Remove the wires after the cutting attachment has stopped turning.
  - Before placing the grass/weed trimmer on the ground, make sure the cutting attachment stops turning.  
Note that the cutting attachment is turning by inertia right after returning the throttle trigger and while the engine is idling.
- The grass/weed trimmer is faulty when the engine is idling by returning the throttle but the cutting attachment keeps turning, and idle speed adjustment must be made. Consult your authorized Honda dealer.
- Keep all nuts, bolts and screws tight to be sure the grass/weed trimmer is in safe working condition. Regular maintenance is an essential aid to user's safety and retaining a high level of performance.



**▲WARNING****To ensure safe operation****Operator Responsibility**

- Do not use the grass/weed trimmer with worn or damaged parts. Parts must be replaced, or repaired. Replace worn or damaged parts with Honda genuine parts. Non equivalent quality parts may damage the machine and be prejudicial to your safety.
- Adjust the holding position of your grass/weed trimmer.  
Be sure to adjust the holding position with the engine stopped. Adjust the carrying harness so that the hook is positioned at your hip. Hook the grass/weed trimmer to the carrying harness. Adjust the carrying harness length so that the cutting attachment is parallel to the ground and stays above the ground keeping the clearance specified below.  
Note that it might be hard to hold the grass/weed trimmer in the correct position if you are very tall. Do not operate the grass/weed trimmer if the cutting attachment is close to your feet when you hold the grass/weed trimmer at the correct position.
- Check the balance of the grass/weed trimmer between its front and rear sides for proper control and less fatigue.  
Hold the grass/weed trimmer in the correct position as described above. Slacken your grip on the handle gradually. Do not release but put your hands lightly on the handle and check that the cutting attachment-to-ground clearance does not change large this time. Balancing adjustment is necessary if the cutting attachment rises above your knees. Do not operate the grass/weed trimmer without the balancing adjustment.

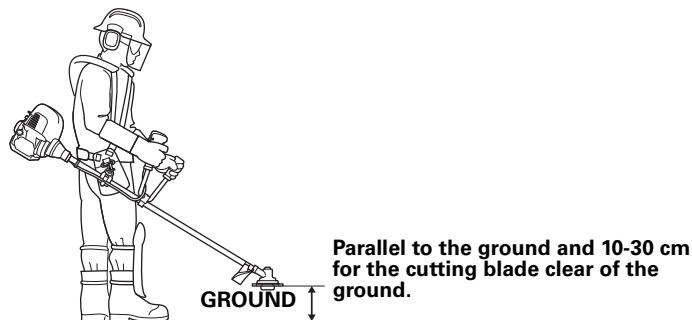

- Hold the grass/weed trimmer firmly with your both hands during operation to keep the trimmer under control at all times.

**▲WARNING**

**To ensure safe operation**

**Operator Responsibility**

- **Injury caused by vibration and cold:**  
You may feel the prickling or burning pain in your fingers, and the fingers may lose color and feeling depending on your constitution. It is believed that these symptoms are brought by vibration and/or exposure to cold. The specific trigger point of these symptoms are not identified yet, but observe the following instructions.
  - \* Limit the amount of time you spend operating the grass/weed trimmer in a day.  
A day's work should consist of the work with the grass/weed trimmer and the other work without the hand-held equipment so you can limit the amount of time when your hands are exposed to the machine vibration.
  - \* Keep your body warm, especially your hands, wrists and arms.
  - \* Take your breaks at shorter intervals and arm exercises well to maintain good blood circulation. Do not smoke while working.
  - \* When you feel discomfort, redness and swelling of the fingers followed by whitening and loss of feeling, consult your doctor promptly.
- **Injury caused by repeated operation:**  
Performing the repeated operation for a prolonged time may cause injury. Observe the following instructions to reduce the causes of the injury.
  - \* Avoid the repeated operation by using your wrist(s) in bent, stretched or twisted position.
  - \* Take your breaks regularly to minimize the effect of the repeated operation. Take your time when performing the repeated operation. Do not rush to operate the grass/weed trimmer.
  - \* When your fingers, hands, wrists and/or arms are throbbing or numbed, consult your doctor.

---

**▲WARNING**

**To ensure safe operation**

**Child Safety**

- Keep children indoors and supervised at all times any outdoor power grass/weed trimmer is being used nearby. Young children move quickly and are attracted especially to the grass/weed trimmer and trimming activity.
- Never assume children will remain where you last saw them. Be alert and turn the grass/weed trimmer off if children enter the area.
- Children should never be allowed to operate the grass/weed trimmer, even under adult supervision.

**Thrown Object Hazard**

Objects hit by the wheeling cutting attachment can be thrown from the grass/weed trimmer with great force, and may cause serious injury.

- Thoroughly inspect the area where the grass/weed trimmer is to be used and remove all objects (stones, branches, wires, bones, etc...) which may be thrown by the wheeling cutting attachment.

**▲WARNING****To ensure safe operation****Fire and Burn Hazard**

Gasoline is extremely flammable, and gasoline vapor can explode. Use extreme care when handling gasoline. Keep gasoline out of reach of children.

- Store fuel in containers specifically designed for this purpose.
- Refuel outdoors only, and do not smoke while refueling or handling fuel.
- Add fuel before starting the engine. Never remove the cap of the fuel tank or add gasoline while the engine is running or when the engine is hot.
- If gasoline is spilled, do not attempt to start the engine but move the grass/weed trimmer away from the area of spillage and avoid creating any source of ignition until gasoline vapors have dissipated.
- Tighten all fuel tanks and container caps securely.  
When you start the engine after refueling, be sure to start the engine at least 3 m away from the refueling spot.
- Never store the grass/weed trimmer with gasoline in the tank inside a building where fumes may reach an open flame, spark or high temperature source.
- Allow the engine to cool before storing in any enclosure.
- To reduce the fire hazard, keep the grass/weed trimmer, especially the engine, muffler, the gasoline storage area as well, free of grass, leaves, or excessive grease.  
Do not leave containers of vegetable matters in or near a building.
- If the fuel tank has to be drained, this should be done outdoors, with a cold engine.

---

**▲WARNING**

**To ensure safe operation**

**Carbon Monoxide Poisoning Hazard**

Exhaust contains poisonous carbon monoxide, a colorless and odorless gas. Breathing exhaust can cause loss of consciousness and may lead to death.

- If you run the engine in an area that is confined or even partially enclosed, the air you breathe could contain a dangerous amount of exhaust gas. To keep exhaust gas from building up, provide adequate ventilation.
- Replace faulty muffler.
- Do not operate the engine in a confined space where dangerous carbon monoxide fumes can collect.

## 2. SAFETY LABEL LOCATIONS

Your grass/weed trimmer must be used with care. Therefore, decals have been placed on the machine, to remind you pictorially of main precautions to take during use. Their meanings are explained on page 3.

These decals are considered as a part of the grass/weed trimmer. Should one become detached or unreadable, contact your Honda dealer for its replacement.

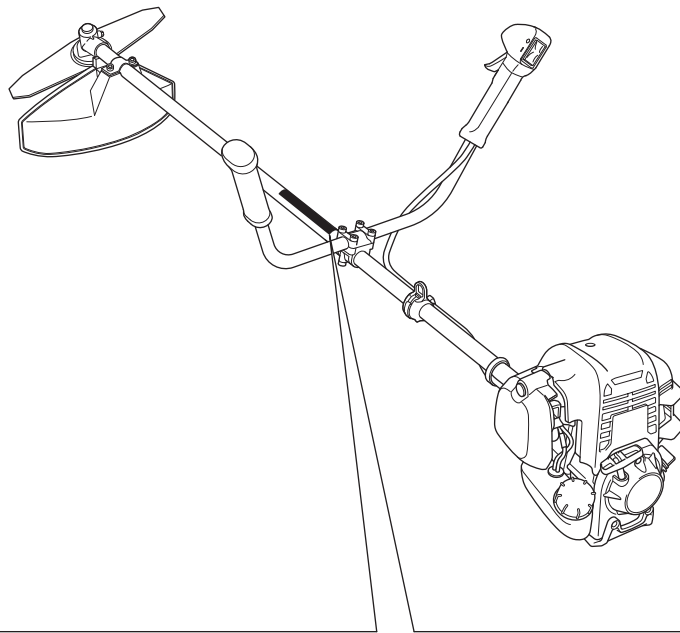

READ OWNER'S MANUAL



### 3. COMPONENT IDENTIFICATION

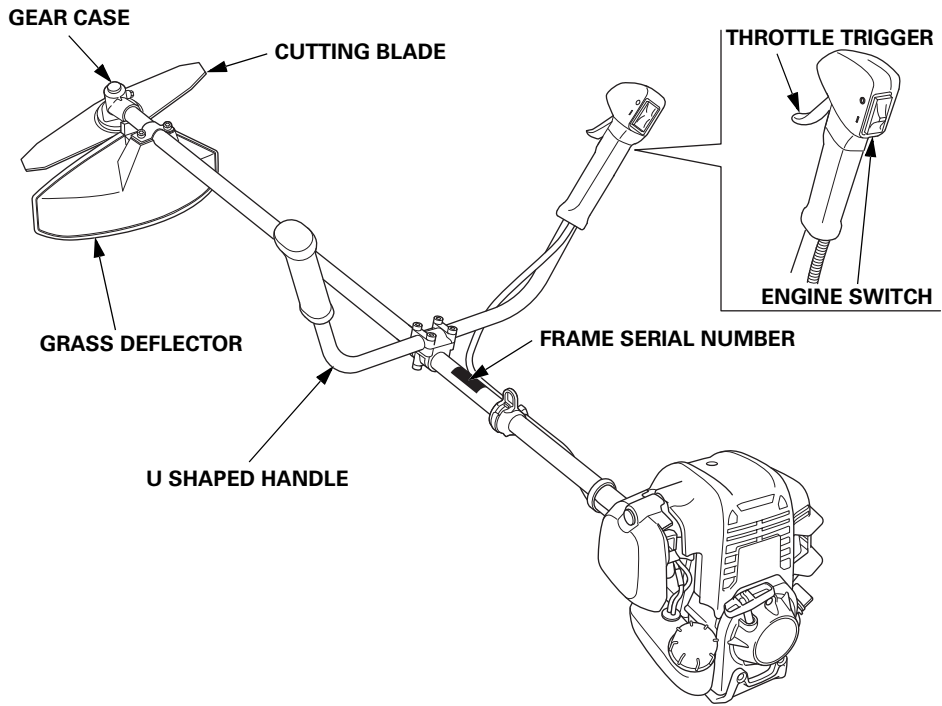

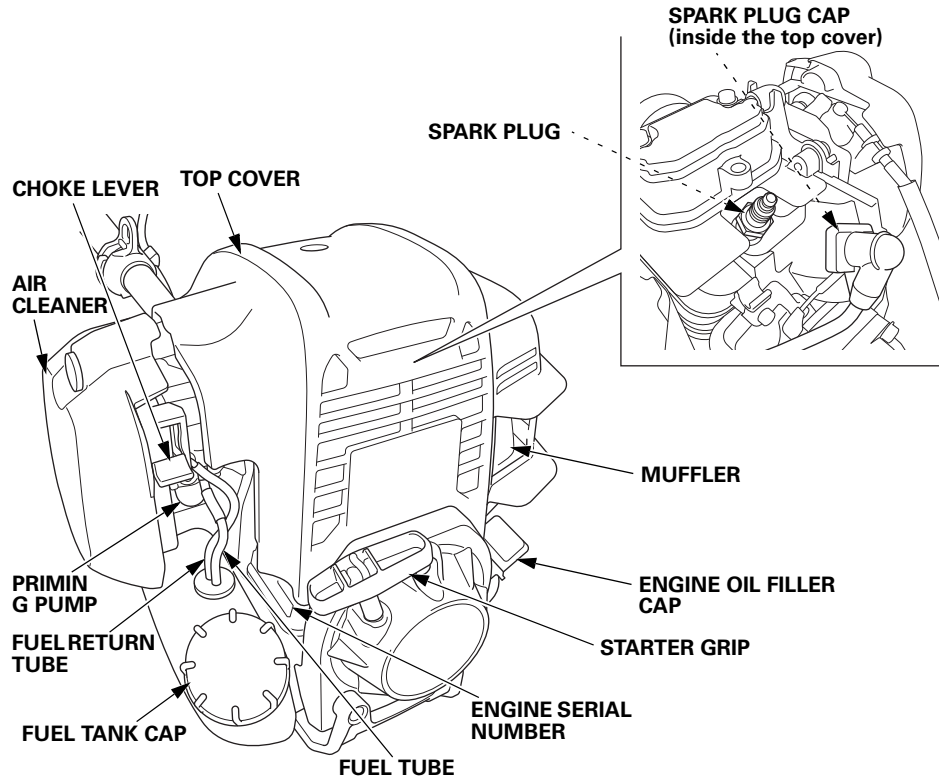

Record the frame serial number (see page 15), engine serial number, date purchased in the spaces below. You will need these information when ordering parts, and when making technical or warranty inquiries.

Frame serial number: \_\_\_\_\_

Engine serial number: \_\_\_\_\_

Date purchased: \_\_\_\_\_



## 4. CONTROLS

### 1. Engine switch

The engine switch enables and disables the ignition system.

The engine switch must be in the ON position for the engine to run.

Turning the engine switch to the OFF position stops the engine.

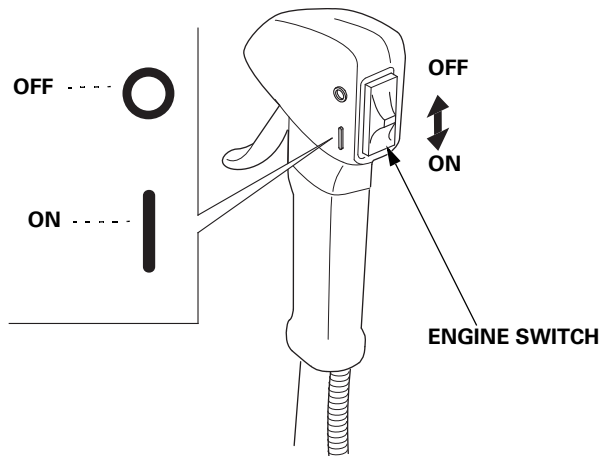

### 2. Priming pump

Pressing the priming pump feeds the gasoline from the fuel tank to the carburetor. This procedure is necessary for starting the engine.

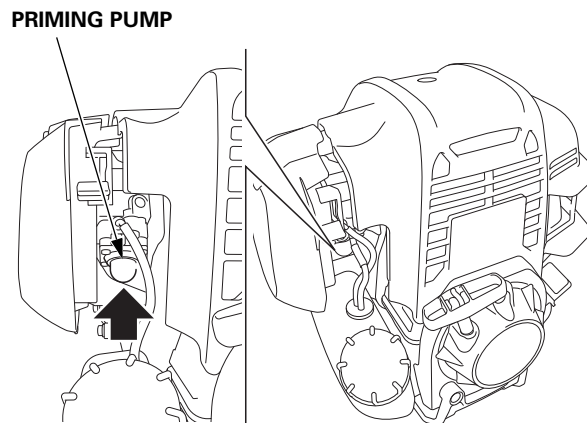

### 3. Choke lever

The choke lever opens and closes the choke valve in the carburetor.

The CLOSED position enriches the fuel mixture for starting a cold engine.

The OPEN position provides the correct fuel mixture for operation after starting, and for restarting a warm engine.

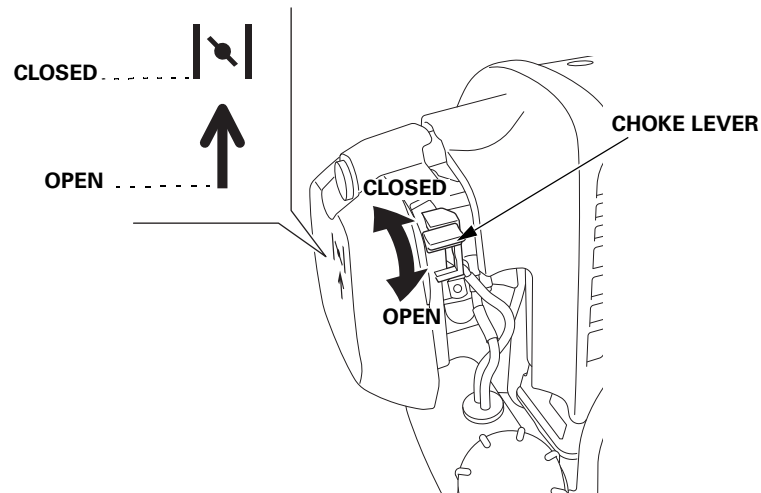

### 4. Starter grip

Pulling the starter grip operates the recoil starter to crank the engine for starting.

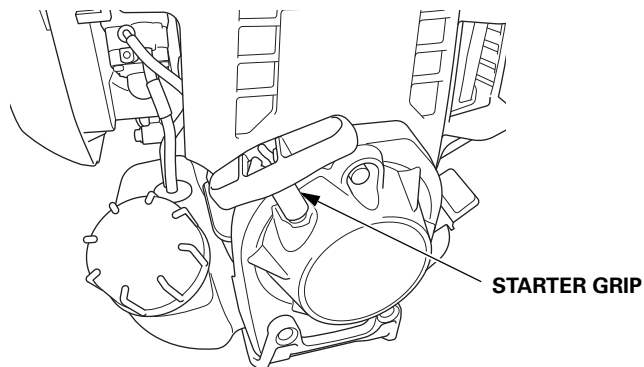

## 5. Throttle trigger

The throttle trigger controls engine speed.

Pulling and releasing the throttle trigger shown below makes the engine run faster or slower.

By pulling the throttle trigger gradually, the engine speed increases and the cutting attachment starts to run. Pull the throttle trigger more to accelerate the engine speed and the cutting rotating speed.

By releasing the throttle trigger, the engine speed decreases and the cutting attachment keeps turning for a while by inertia, then it stops.

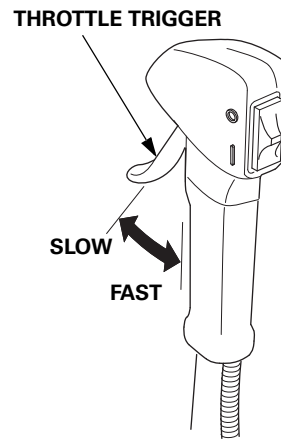

## 6. Quick-release latch

The quick-release latch tab is provided to detach the grass/weed trimmer from your body in an emergency.

Pull up the quick-release latch tab and push the grass/weed trimmer away to detach the grass/weed trimmer from the carrying harness. After releasing the grass/weed trimmer by quick release latch, the hook remains on the hanger. Attach the hook to the waist pad after using the quick release latch.

### NOTE:

When the quick release latch is used to detach the grass/weed trimmer, the grass/weed trimmer may fall down. When you check quick release function, do not attach the grass/weed trimmer to the hook on the waist pad to prevent the grass/weed trimmer from falling down and being damaged.

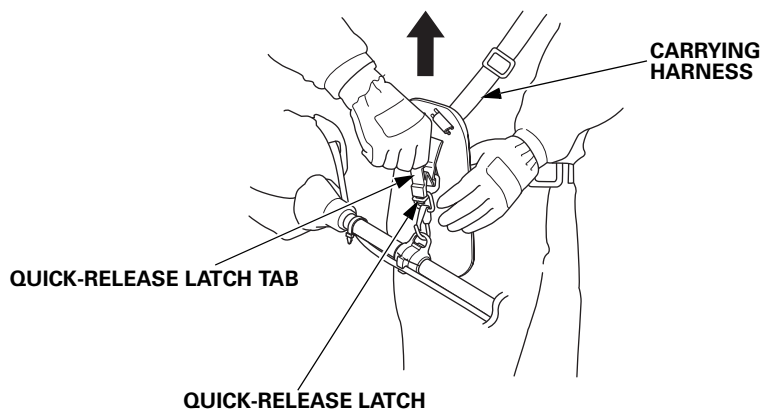

## 5. PRE-OPERATION CHECKS

For safe and efficient trimming, always conduct a pre-operation checks.

### **▲WARNING**

**Perform the pre-operation checks on a firm, level surface with the blade stopped and make sure that the engine switch is in the OFF position.**

Before each use, look around and underneath the engine for signs of oil or gasoline leaks.

### **1. Check the engine oil level**

#### **CAUTION:**

**Running the engine with low oil level will cause serious engine damage.**

1. Place the grass/weed trimmer on a level surface and remove the oil filler cap.
2. Check the oil level: it should reach to the edge of the oil filler neck, and check the engine oil for contamination and deterioration.
3. If the oil level is low, fill with the recommended oil (see page 22) to the upper limit (edge of the oil filler neck).  
If the oil is contaminated or deteriorated, replace it (see page 49).
4. Install the oil filler cap.

Every 10 hours, check the engine oil level and replenish oil up to the top of the oil filler neck if the engine is operated for more than 10 hours continuously.

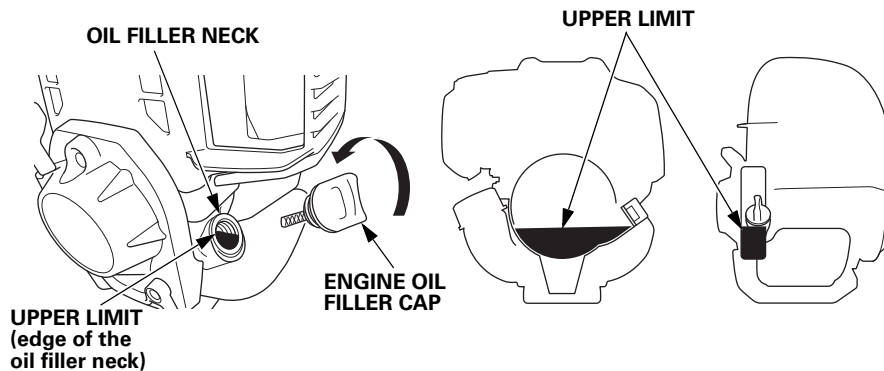

Use 4-stroke motor oil that meets or exceeds the requirements for API service classification SE or later (or equivalent). Always check the API service label on the oil container to be sure it includes the letters SE or later (or equivalent).

SAE 10W-30 is recommended for general use. Other viscosities shown in the chart may be used when the average temperature in your area is within the indicated range.

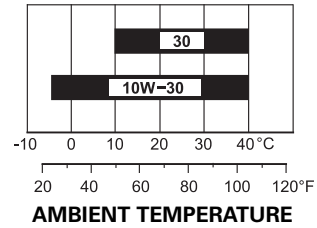

**CAUTION:**

**Using nondetergent oil or 2-stroke engine oil could shorten the engine's service life.**

---

## 2. Check the fuel level

Use unleaded gasoline with a Research Octane Number of 91 or higher (a Pump Octane Number of 86 or higher).

Never use gasoline that is stale, contaminated, or mixed with oil. Avoid getting dirt or water in the fuel tank.

### **▲WARNING**

- **Gasoline is extremely flammable and is explosive under certain conditions.**
- **Refuel in a well-ventilated area with the engine stopped. Do not smoke or allow flames or sparks in the area where the engine is refueled or where gasoline is stored.**
- **Do not overfill the fuel tank (there should be no fuel in the filler neck). After refueling, make sure the tank cap is closed properly and securely.**
- **Be careful not to spill fuel when refueling. Spilled fuel or fuel vapor may ignite. If any fuel is spilled, make sure the area is dry before starting the engine.**
- **Avoid repeated or prolonged contact with skin or breathing of vapor. KEEP OUT OF REACH OF CHILDREN.**

### **CAUTION:**

**Gasoline substitutes are not recommended; they may be harmful to fuel system components.**

1. Check the fuel level visually from the outside of the fuel tank while keeping the fuel filler neck upright.
2. If the fuel level is low, refuel the fuel tank until the level as specified. Remove the fuel tank cap gradually to release a pressurized air in the fuel tank. Fuel in the fuel tank may spout out, if the fuel tank cap is removed quickly.

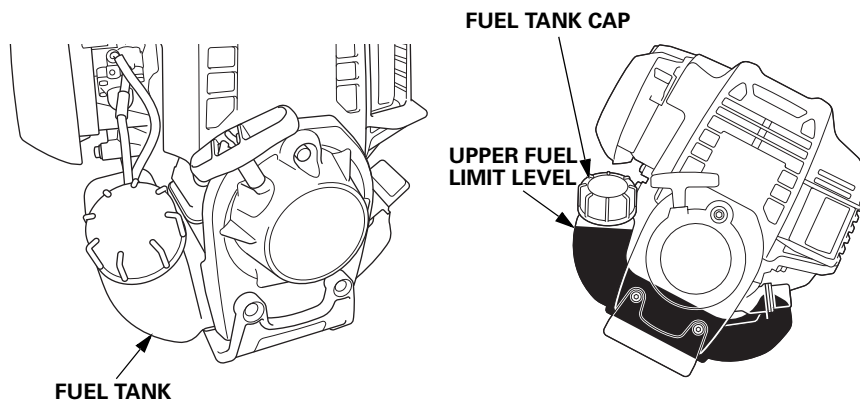



**NOTE:**

Gasoline spoils very quickly depending on factors such as light exposure, temperature and time.

In worst cases, gasoline can be contaminated within 30 days.

Using contaminated gasoline can seriously damage the engine (carburetor clogged, valve stuck).

Such damage due to spoiled fuel is disallowed from coverage by the warranty.

To avoid this please strictly follow these recommendations:

- Only use specified gasoline (see page 23).
- Use fresh and clean gasoline.
- To slow deterioration, keep gasoline in a certified fuel container.
- If long storage (more than 30 days) is foreseen, drain fuel tank and carburetor (see pages 64 and 65).

**Gasolines containing alcohol**

If you decide to use a gasoline containing alcohol (gasohol), be sure it's octane rating is at least as high as that recommended by Honda. There are two types of "gasohol": one containing ethanol, and the other containing methanol. You may use unleaded gasoline containing no more than 10% ethanol (E10) or 5% methanol (methyl or wood alcohol) by volume. In addition, methanol must contain cosolvents and corrosion inhibitors. Never use gasoline containing more than 5% methanol, even if it has cosolvents and corrosion inhibitors.

**NOTE:**

- Fuel system damage or engine performance problems resulting from the use of fuels that contain alcohol is not covered under the warranty. Honda cannot endorse the use of fuels containing methanol since evidence of their suitability is as yet incomplete.
- Before buying fuel from an unfamiliar station, try to find out if the fuel contains alcohol, if it does, confirm the type and percentage of alcohol used. If you notice any undesirable operating symptoms while using a gasoline that contains alcohol, or one that you think contains alcohol, switch to a gasoline that you know does not contain alcohol.

### 3. Check the air cleaner

**CAUTION:**

**Never run the engine without the air cleaner; rapid engine wear will result.**

1. Move the choke lever to the CLOSED (upwards) position.
2. Loosen the screw and remove the air cleaner cover from the air cleaner body.
3. Check the air cleaner element for dirt or obstruction.  
Clean the air cleaner element, if it is dirty (see page 51).
4. Reinstall the air cleaner element.
5. Reinstall the air cleaner cover and tighten the screw securely.

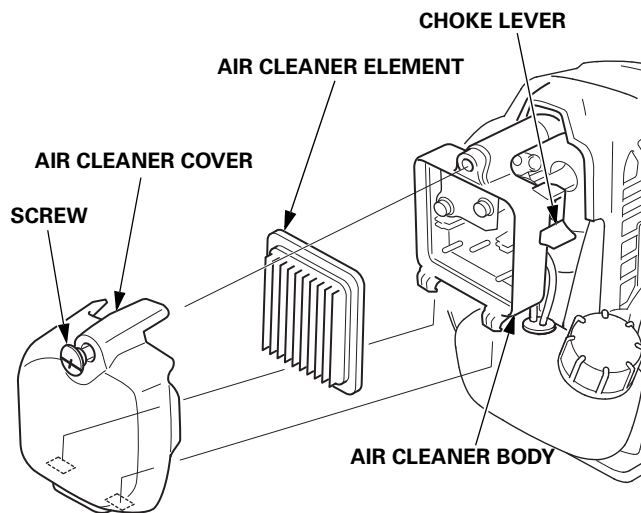

#### 4. Check the throttle cable free play

1. Move the choke lever to the CLOSED (upwards) position.
2. Loosen the screw and remove the air cleaner cover from the air cleaner body.

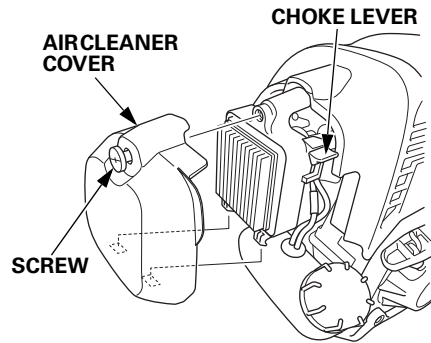

3. Check the throttle cable free play at the tip of the cable by pulling and releasing the throttle trigger a few times. It should be 0.5–2.5 mm at the tip of the throttle cable.  
If the free play is not as specified above, adjust the free play (see page 57).

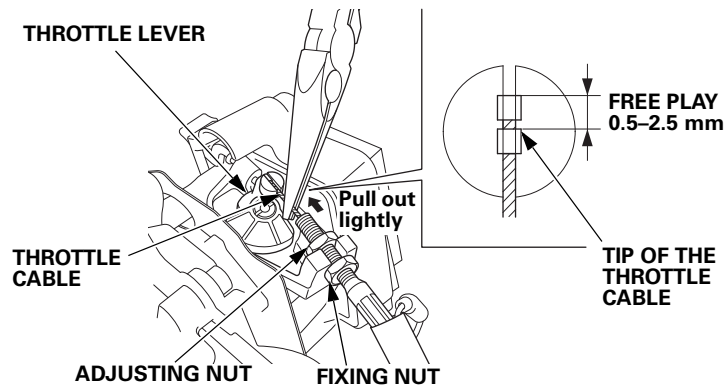

4. Check the throttle trigger operates smoothly and always spring back to the idle position.
5. Reinstall the air cleaner cover and tighten the screw securely.

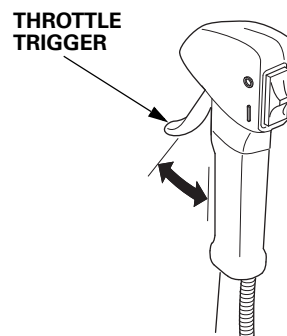

## 5. Adjustment of the carrying harness

### ▲WARNING

**Be sure to wear the carrying harness before using the grass/weed trimmer. Otherwise, injuries might occur due to its instability.**

1. Wear the carrying harness so that the hip pad is on the right side of your body.  
Make sure the harness does not twist.
2. Firmly secure the carrying harness latch on the front of your body until it clicks. To unlock the carrying harness latch, pull the harness to the right and to the left while pressing the latch.

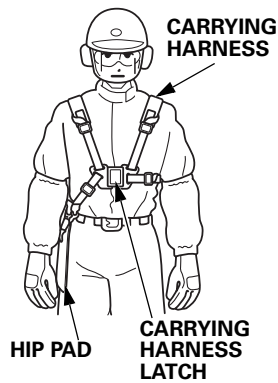

3. Adjust the length of the harness as shown in the figures below.

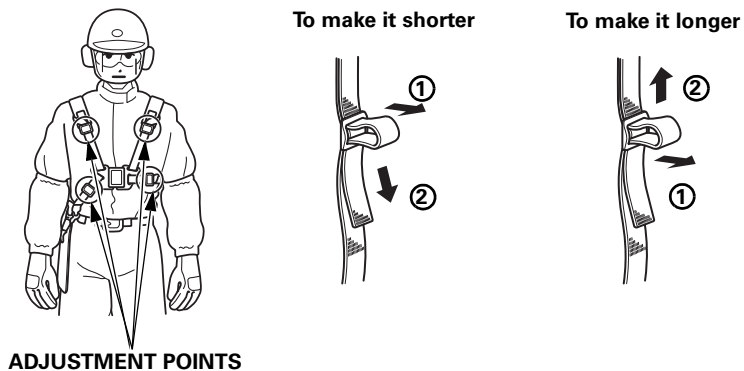

4. Roll the end of the harness toward your body and fasten it.



APPLICABLE POINTS

### 6. Check the carrying harness

1. Wear the carrying harness.
2. Set the hook to the hanger.
3. Check that the hook is fastened to the hanger securely.

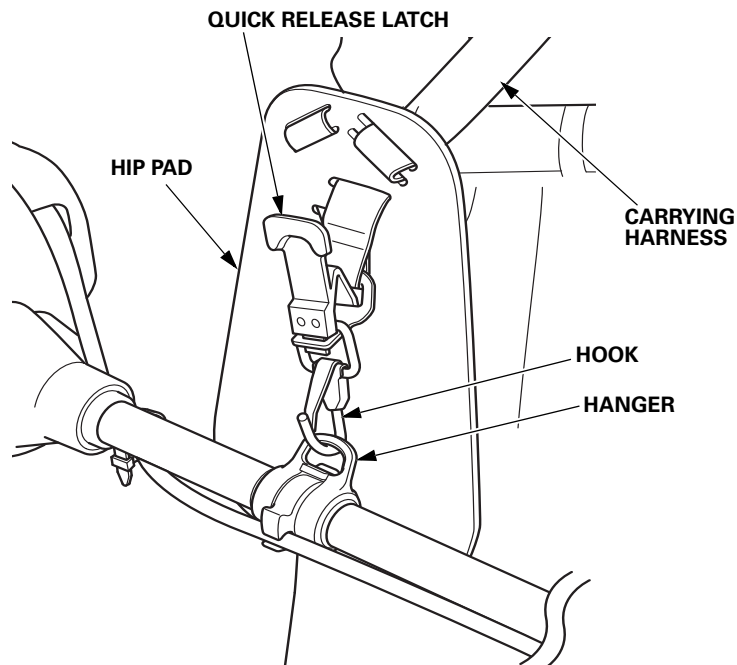

## 7. Check the quick-release latch

1. Wear the carrying harness.
2. Check the latch is released as soon as the quick-release latch tab is pulled upwards while holding the hip pad with your left hand.
3. Insert the latch tongue in the slot of the quick-release latch.

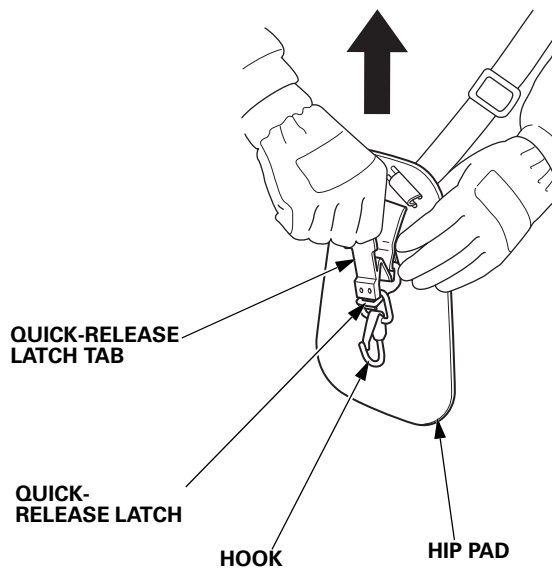

If the latch is not released, have your device inspected and repaired by your servicing dealer.

### NOTE:

When the quick release latch is used to detach the grass/weed trimmer, the grass/weed trimmer may fall down. When you check quick release function, do not attach the grass/weed trimmer to the hook on the waist pad to prevent the grass/weed trimmer from falling down and being damaged.

## 8. Check the cutting attachment

### Cutting blade check:

**▲WARNING**

For safety, inspect the cutting blade for wear and damage and check the tightness of the cutting blade nut before starting the engine. Operating the grass/weed trimmer with a worn, cracked, or damaged cutting blade can cause a personal injury or equipment damage. A worn, cracked or damaged blade can break and pieces of the damaged blade can hit the operator or bystanders causing death or serious injury.

**CAUTION:**

Wear heavy gloves to protect your hands, when working around the cutting blade.

1. Stop the engine with the engine switch to the OFF position.
2. Check the tightness of the cutting blade nut.  
Tighten the nut if it is loose (see page 53).  
If it is hard to do it yourself, consult your authorized Honda dealer.
3. Check the cutting blade for wear, bend, crack and other damage.  
If the blade is worn out, cracked, chipped, or otherwise damaged replace the damaged blade with new one which is a genuine Honda replacement cutting blade.

A dull blade can be sharpened.

If it is hard to do it yourself, consult your authorized Honda dealer.

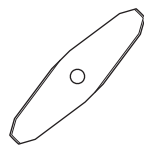

**NORMAL**

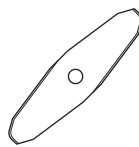

**WORN**

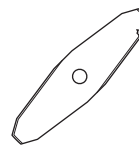

**NICKED**

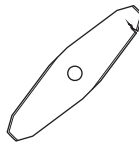

**CRACKED**

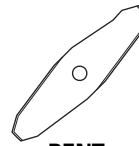

**BENT**

## 9. Check the grass deflector

### ▲WARNING

- **Never use the grass/weed trimmer without its grass deflector. Stones or other foreign objects thrown outward by the wheeling cutting attachment or contact with the wheeling cutting attachment could cause personal injury or property damage.**

1. Stop the engine with the engine switch to the OFF position.
2. Inspect the grass deflector to be sure that they are correctly installed and are not damaged. If the grass deflector is damaged, replace it before using the grass/weed trimmer.
3. Check the grass deflector mounting bolts for looseness. Tighten the bolts securely, if necessary.
4. Keep the grass deflector position and direction same as below. Please avoid the distance between blade and deflector as recommend position to not touch or hit each other.

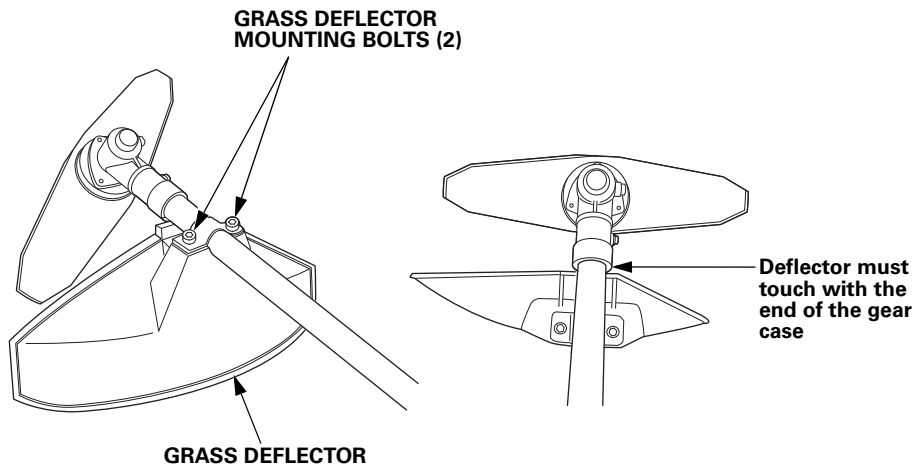



## 10. Check the gear case

### **▲ WARNING**

For safety, check the gear case for wear and damage before starting the engine.

### **CAUTION:**

Wear heavy gloves to protect your hands, when working around the gear case.

### **Inspect the gear case:**

1. Stop the engine with the engine switch to the OFF position.
2. Check if there is grass or thread tangled between the grass guard and cutting blade. If there is, remove it.
3. After removing grass or thread, check if there is contaminated material such as mud or dirt in between the grass guard and cutting blade. If there is, remove the cutting blade and clean the gear case (see page 53). When cleaning, perform "Inspect the drive bolt" (see page 35) at the same time.

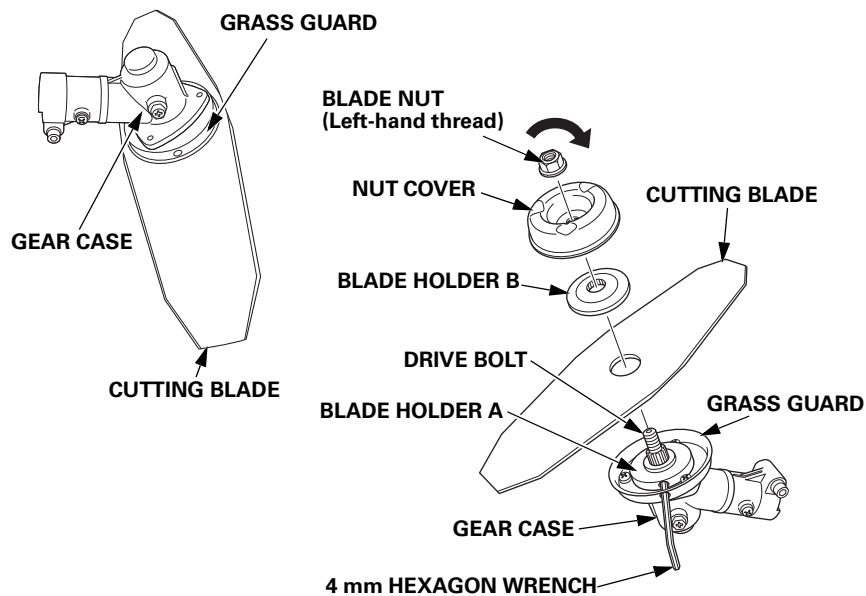

---

### **Cleaning the gear case:**

If there is contaminated material such as grass, thread, mud, or dirt in between the gear case, grass guard, and blade holder A, clean them using the following procedure.

1. Stop the engine with the engine switch to the OFF position.
2. Remove the cutting blade. (See page 53)
3. Remove the blade holder A.
4. Remove grass, thread, mud, or dirt around blade holder A and the drive bolt.

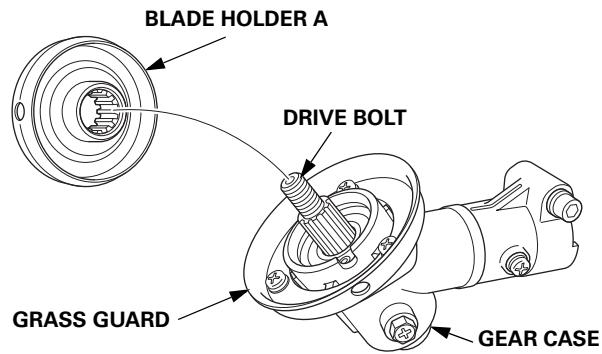

---

### Inspect the drive bolt :

Hold the drive bolt, move it left and right, and check if it is loose. If it is loose, the gear case must be replaced. Contact your Honda dealer for replacement.

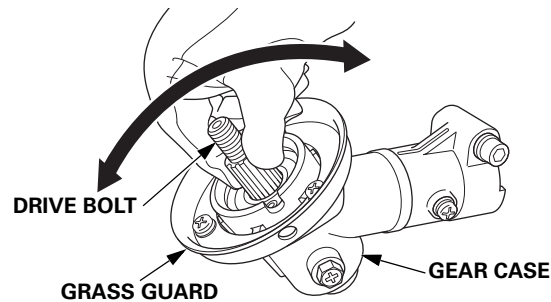

After "Cleaning the gear case", and "Inspect the drive bolt", make sure to assemble blade holder A to the gear case before attaching the cutting blade. To attach the cutting blade, refer to page 53.

### Inspect the nut cover :

Check the wear of the nut cover. If there are cracks or holes in the nut cover, replace it. Contact your Honda dealer for replacement.

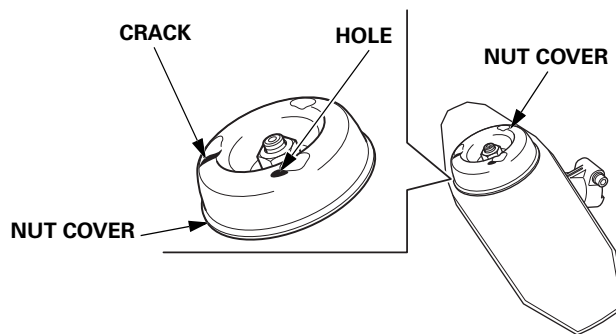

## 11. Check all bolts and nuts

Check the bolt and nut whether it is loosen before every work. If the bolts or nuts come loose, tighten them.

1. Check each bolt and nut for looseness. Tighten them securely if necessary.
2. Check the handle for loose mounting bolts or screws, and tighten them securely if necessary. The recommended handle angle is 90 degree.

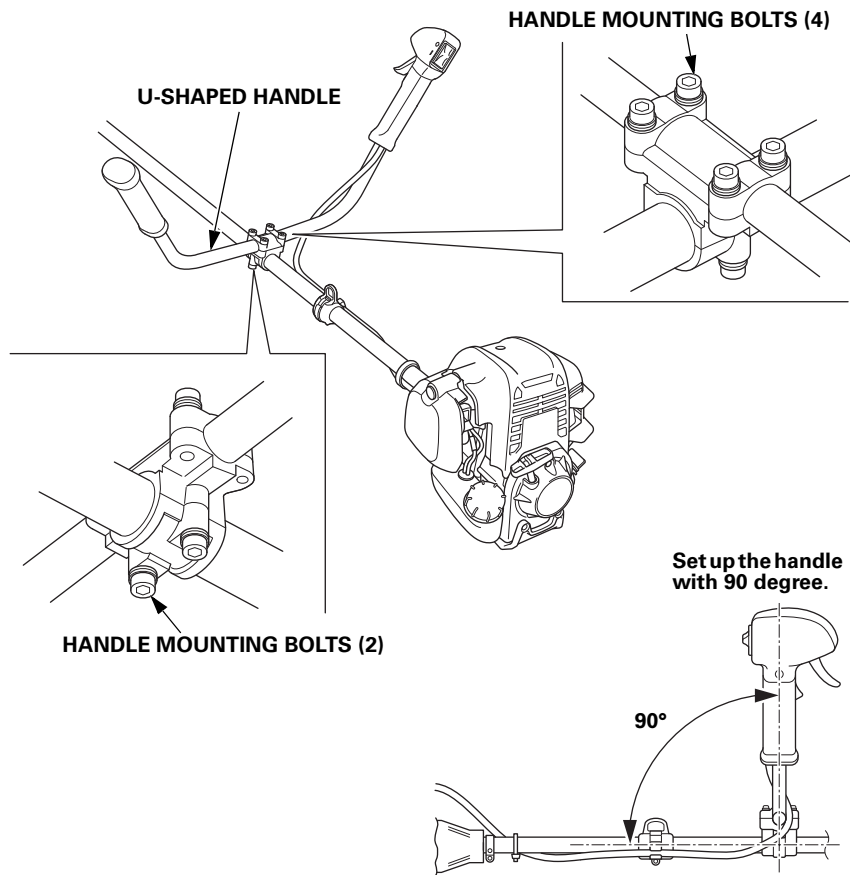

## 6. STARTING THE ENGINE

### **▲WARNING**

- Exhaust gas contains poisonous carbon monoxide. Never run the engine in an enclosed area. Be sure to provide adequate ventilation.
- Start the engine in a place away from the people, pets, and surrounding buildings. Be sure there are no obstacles in the working area.

### **CAUTION:**

**Do not start the engine with the cutting attachment touched the ground or any obstruction. The trimmer can make unexpected movement causing injury in your legs, etc.**

### **NOTE:**

- Wear protective clothing and protective device. (See page 5)
- Place the grass/weed trimmer in an area free from the obstacles, and be sure the cutting attachment is not in contact with the ground and other materials.

1. Turn the engine switch to the ON position.

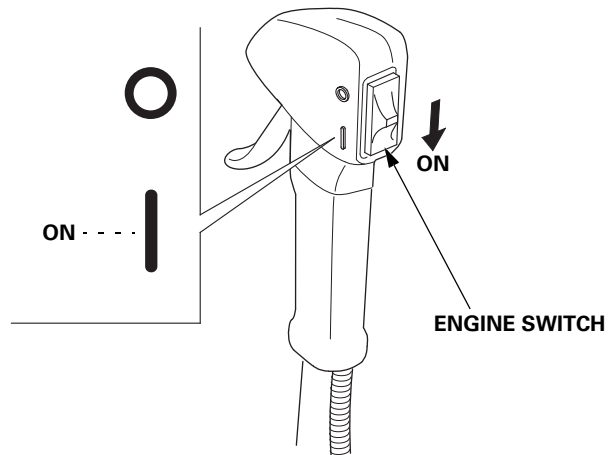

2. To start a cold engine, move the choke lever to the CLOSED position.

To restart warm engine, leave the choke lever in the OPEN position.

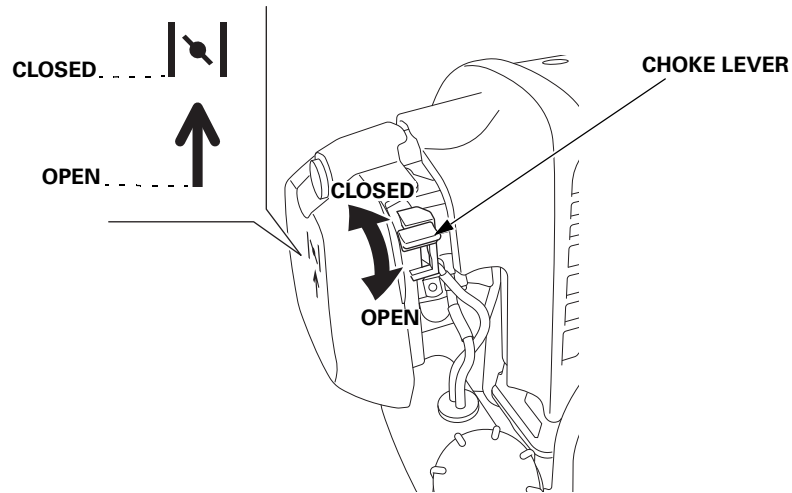

3. Press the priming pump several times until the priming pump is filled with fuel.

Even if the priming pump is pressed too many times, the extra fuel will return to the fuel tank.

If the priming pump is not pressed enough, the engine may not start.

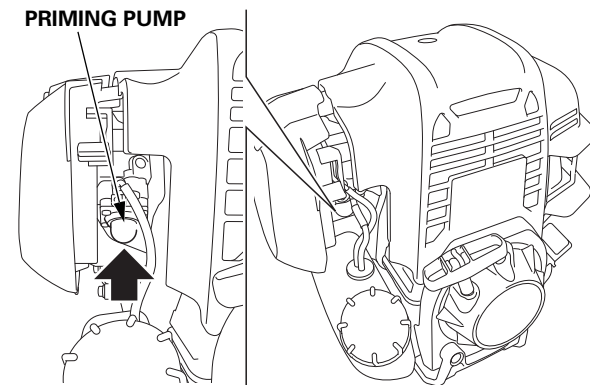

4. Pull the starter grip lightly until you feel resistance while stepping on the carrying frame with your foot and holding the carrying frame with your hand, then pull briskly in the direction of the arrow as shown below. Return the starter grip gently.

**CAUTION:**

- Do not allow the starter grip to snap back against the engine. Return it gently to prevent damage to the starter.
- Damage may result if the starter grip is pulled while the engine is running.

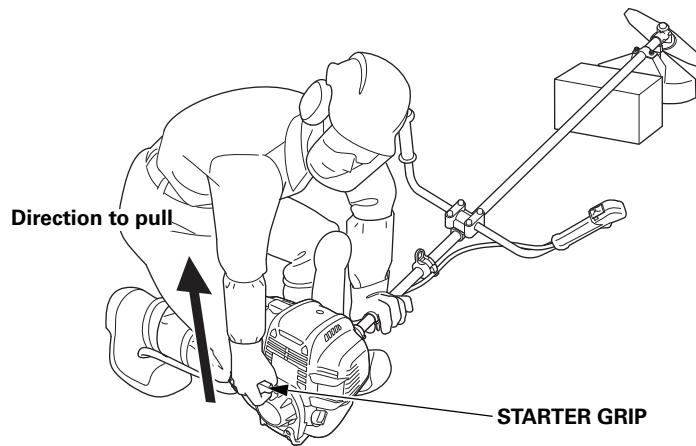

5. If the choke lever has been moved to the CLOSED position to start the engine, gradually move it to the OPEN position as the engine warms up.

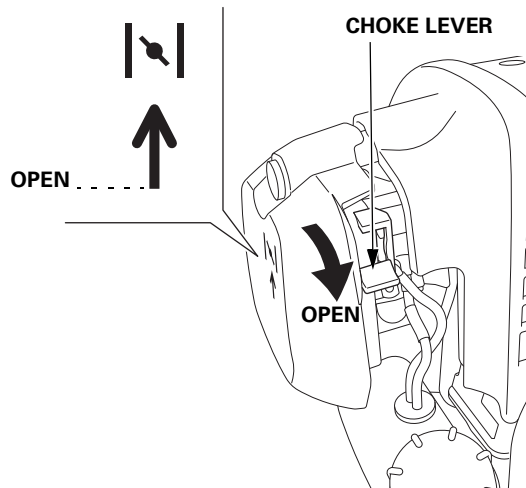

---

### **Carburetor Modification for High Altitude Operation.**

At high altitude, the standard carburetor air-fuel mixture will be too rich. Performance will decrease, and fuel consumption will increase. A very rich mixture will also foul the spark plugs and cause hard starting. Operation at an altitude that differs from that at which this engine was certified, for extended periods of time, may increase emissions.

High altitude performance can be improved by specific modifications to the carburetor. If you always operate your grass/weed trimmer at altitudes above 1,500 meters, have your dealer perform this carburetor modification. This engine, when operated at high altitude with the carburetor modifications for high altitude use, will meet each emission standard throughout its useful life.

Even with carburetor modification, engine horsepower will decrease about 3.5% for each 300-meter increase in altitude. The effect of altitude on horsepower will be greater than this if no carburetor modification is made.

#### **CAUTION:**

**When the carburetor has been modified for high altitude operation, the air-fuel mixture will be too lean for low altitude use. Operation at altitudes below 1,500 meters with a modified carburetor may cause the engine to overheat and result in serious engine damage. For use at low altitudes, have your servicing dealer return the carburetor to original factory specifications.**



## 7. TRIMMING OPERATION

Read and understand the safety instructions on pages 3 to 13 before operating the grass/weed trimmer.

If you notice any abnormal sound, smell, vibration, or other unusual signs, stop the engine immediately and consult your authorized Honda dealer.

### Grass/weed trimmer holding position adjustment:

Stop the engine when adjusting the length of the carrying harness.

1. Adjust the carrying harness so that the hanger is positioned at your right hip (see page 28).
2. Hang the trimmer on the carrying harness hook by its hanger.
3. Keep the trimmer so that the cutting attachment is parallel to the ground by holding the handle with your both hands.
4. Adjust the carrying harness length so that the cutting attachment is parallel to the ground and stays above the ground keeping the clearance specified below.

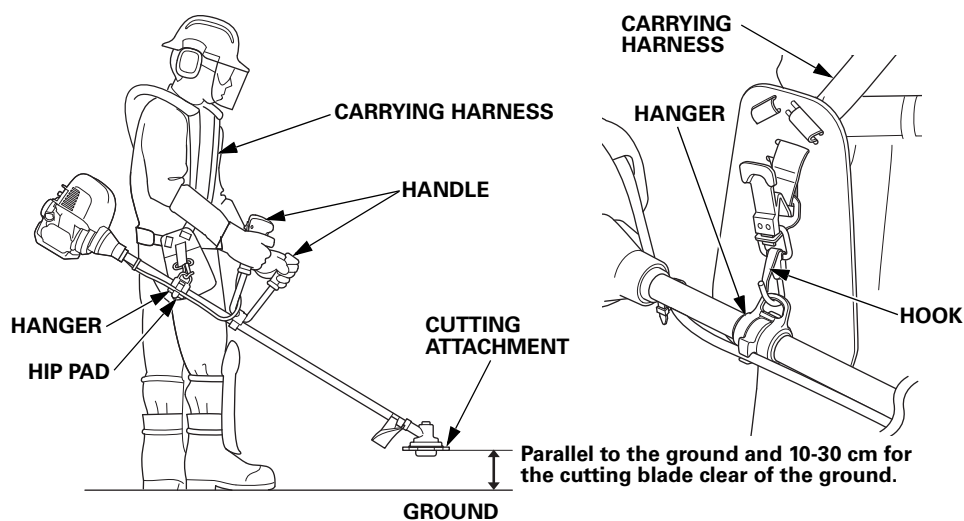

### ▲WARNING

**Do not operate the grass/weed trimmer if the turning cutting attachment could reach your feet. Your feet can get injured if the turning cutting attachment touches your feet.**

---

### Cutting attachment applications:

Your grass/weed trimmer is not designed to cut down the brush.

Stop the engine and check the balance of the grass/weed trimmer between its front and rear sides.

1. Hold the grass/weed trimmer at the correct position.
2. Slacken your grip on the handle gradually. Do not release but put your both hands lightly on the handle, and be sure that the height of the cutting attachment from the ground does not change large this time. Adjustment is necessary if the cutting attachment rises high above your knees. Do not operate the grass/weed trimmer before adjustment, and consult your authorized Honda dealer for adjustment.

### Basic operation:

With the engine idling, hook the trimmer to your carrying harness and hold the trimmer at the correct position. Be careful to avoid contact with the cutting attachment while handling the trimmer with the engine running.

The cutting attachment should not rotate with the engine idling. If there is rotation at idle, adjust the idle speed correctly before using the trimmer. For idle adjustment, consult your authorized Honda servicing dealer.

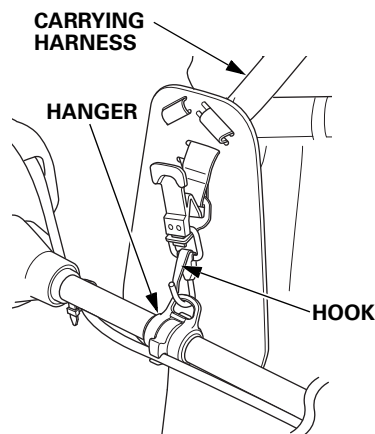

- 
- Hold the trimmer firmly with your both hands, with your fingers and thumbs encircling the handles as shown below. This will help you to keep the trimmer under control at all times.
    - Keep firm footing and balance.
    - Do not overreach.
    - Keep the cutting attachment below your knee height.
    - Keep all part of your body away from the rotating cutting attachment and hot surface.



- Operate the grass/weed trimmer not by using your arm force but by using your waist so that the cutting attachment swings in a level arc from right to left.  
Hold the grass/weed trimmer so that you can shift your weight to the right leg then to the left leg safely and easily, and walk slowly with narrow strides.
- When operating the grass/weed trimmer on a moderate slope, stand at the down side of the slope. The steep slope is slippery and you can lose your balance. Do not operate the grass/weed trimmer on a steep slope.

**CAUTION:**

**Take good care of your step. Do not operate the grass/weed trimmer in a place where is slippery, or you can lose your balance.**

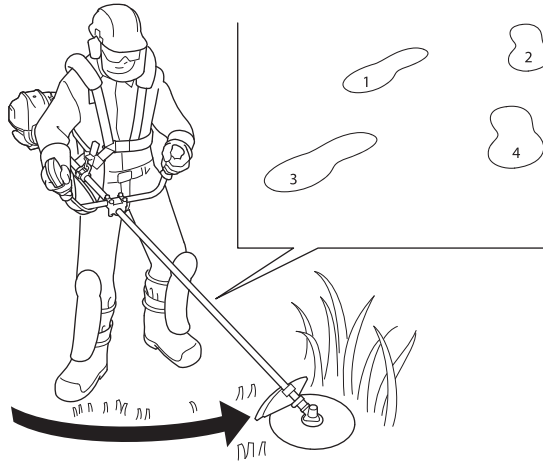

- Your grass/weed trimmer is not designed to cut down the trees. Do not use your grass/weed trimmer as a pruner hook.
- In an emergency, pull up the quick-release latch tab to detach the grass/weed trimmer from the carrying harness.

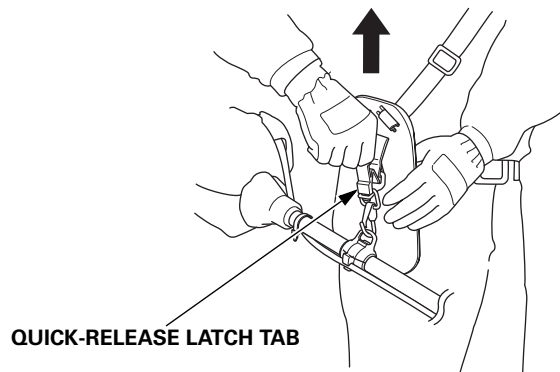

## 8. STOPPING THE ENGINE

1. Release the throttle trigger.
2. Turn the engine switch to the OFF position.

**CAUTION:**

**Note that the cutting attachment keeps turning for a while by inertia after the engine is stopped.**

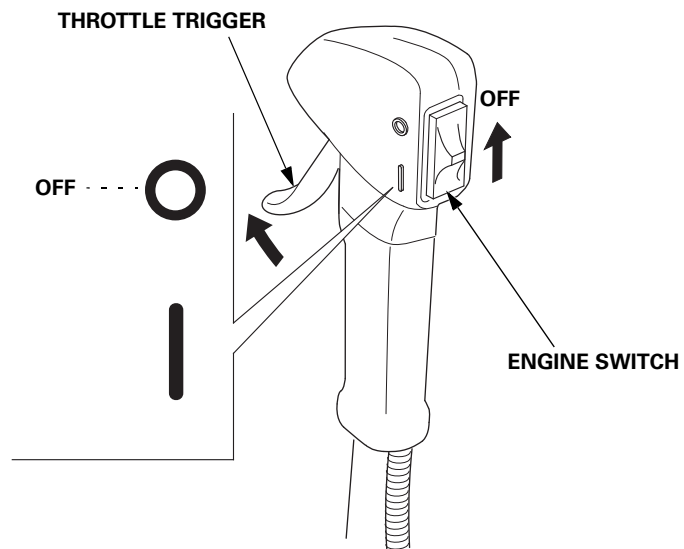

**NOTE:**

Be sure that the engine is stopped and the cutting attachment stops turning before placing the grass/weed trimmer on the ground.

## 9. MAINTENANCE

---

### **▲WARNING**

- **Before performing any maintenance, place the grass/weed trimmer on a level surface, make sure the blade is stopped, and turn the engine switch to the OFF position to be certain the engine will not start accidentally.**
- **The grass/weed trimmer should be serviced by an authorized Honda dealer unless the owner has proper tools and service data and feels he is mechanically qualified.**

### **CAUTION:**

**Use genuine Honda parts or their equivalent for maintenance or repair. Replacement parts which are not of equivalent quality may damage the trimmer.**

Periodic checks and adjustment of the Honda UMK450T is essential if high level performance is to be maintained. Regular maintenance will also help to extend service life. The required service intervals and the kind of maintenance to be performed are described in chart on the following page 47.

For longer service and efficiency, keep the underside of the grass deflector clean and free of accumulated grass clippings by washing it down with a hose after each use and/or cleaning it with a wire brush and scraper.

## Maintenance schedule

REGULAR SERVICE PERIOD (3) Perform at every indicated month or operating hour interval, whichever comes first.	ITEM	Each use	First month or 10 hrs.	Every 3 months or 25 hrs.	Every 6 months or 50 hrs.	Every year or 100 hrs.	Every 2 years or 300 hrs.	Refer to page
Engine oil	Check level	o						21
	Change		o		o			49
Air cleaner	Check	o						26
	Clean			o (1)				51
	Replace					o		51
Spark plug	Check-adjust					o		55, 56
	Replace						o	
Throttle cable	Check	o						27, 57
Carrying harness	Check	o						29
Quick-release latch	Check	o						30
Cutting attachment	Check (Replace if necessary)	o						31
Grass deflector	Check	o						32
Engine cooling fins	Check-clean				o (1)			59
Nuts, bolts, fasteners	Check (Retighten if necessary)	o						36
Fuel tank	Clean					o		60
Fuel filter	Check					o		60
Clutch shoe and drum	Check				o (2) (4)			-
Wear out of gear case	Check				o (2)			-
Gear case	Check-clean	o						33
	Grease						Every year or 30 hrs.	62
Idle speed	Check-adjust					o (2)		-
Valve clearance	Check-adjust					o (2)		-
Combustion chamber	Clean						Every 2 years or every 300 hrs. (2)	-
Fuel tubes	Check						Every year or every 100 hrs. (Replace if necessary) (2)	62
Oil tubes	Check						Every 2 years. (Replace if necessary) (2)	-

### NOTE:

- (1) Service more frequently when used in dusty areas.
- (2) These items should be serviced by your servicing dealer, unless you have the proper tools and are mechanically proficient. Refer to the Honda shop manual for service procedures.
- (3) Log hours of operation to determine proper maintenance intervals.
- (4) These consumption parts should be replaced even a short period if it is necessary.

## Tool kit

The tools supplied are necessary for performing some periodic maintenance, simple adjustments and repairs.

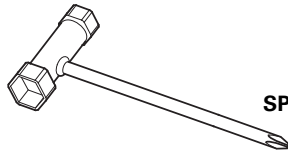

**SPARK PLUG WRENCH**



**8x10mm WRENCH**



**5 mm HEXAGON WRENCH  
4 mm HEXAGON WRENCH**

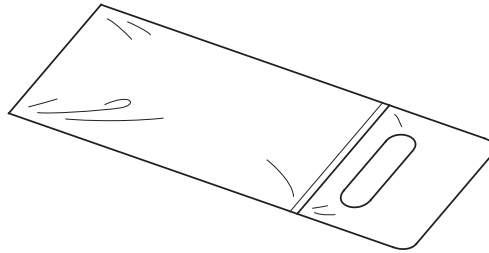

**TOOL BAG**



## 1. Engine oil change

### CAUTION:

If the engine has been running, the engine, muffler and the engine oil are very hot and they remain hot for a while after stopping the engine. To protect you from burn, wait until they cool down before starting the oil change.

### NOTE:

Drain the oil while the engine is still warm to assure rapid and complete draining.

1. Check the fuel tank cap is tightened.
2. Remove the oil filler cap and drain the oil into the oil container by tipping the engine toward the oil filler neck.

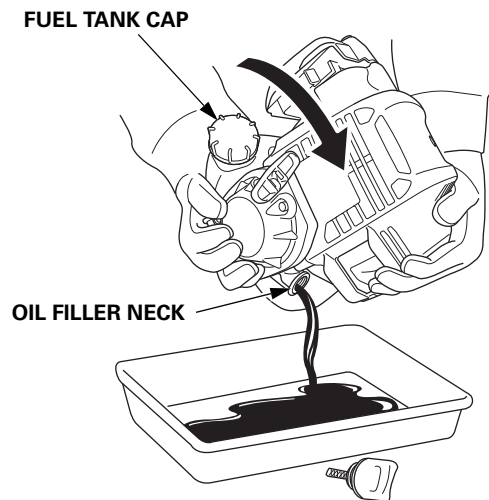

3. Refill with the recommended oil (see page 22) to the upper limit (edge of the oil filler neck).
4. Install the oil filler cap.

**ENGINE OIL CAPACITY:** 0.13 L

Wash your hands with soap and water after handling used oil.

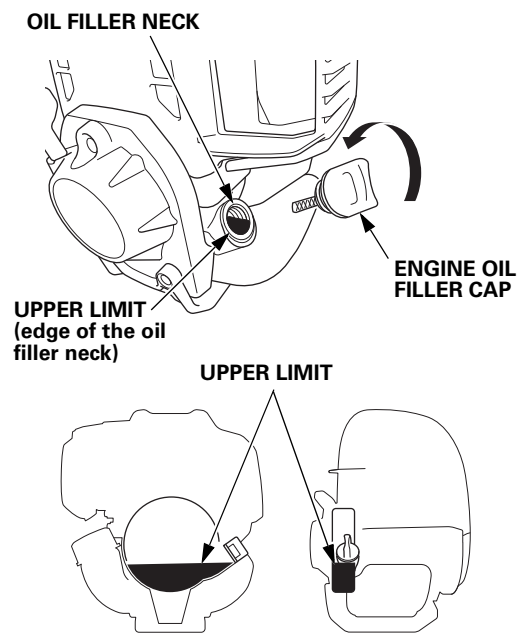

**NOTE:**

Please dispose of used motor oil in a manner that is compatible with the environment. We suggest you take it in a sealed container to your local service station for reclamation. Do not throw it in the trash or pour it on the ground.

## 2. Air cleaner service

A dirty air cleaner will restrict air flow to the carburetor. To prevent carburetor malfunction, service the air cleaner regularly. Service more frequently when operating the grass/weed trimmer in extremely dusty areas.

### **▲WARNING**

**Never use gasoline or low flash point solvents for cleaning the air cleaner element. A fire or explosion could result.**

### **CAUTION:**

**Never run the engine without the air cleaner. Rapid engine wear will result.**

1. Move the choke lever to the CLOSED (upwards) position.
2. Loosen the screw and remove the air cleaner cover from the air cleaner body.

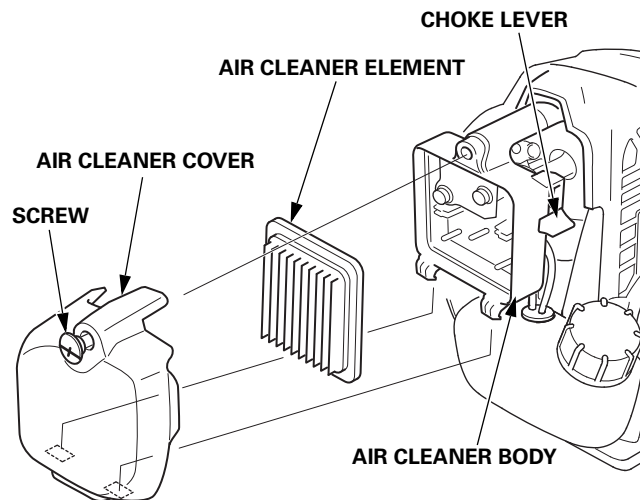

3. Inspect the air filter element, and replace it if it is damaged.  
Always replace the paper air filter element at the scheduled interval (see page 47).
4. Clean the air filter element if it is to be reused.  
Tap the paper air filter element several times on a hard surface to remove dirt, or blow compressed air [not exceeding 200 kPa (2.0 kgf/cm<sup>2</sup>, 29 psi)] through the filter element from the air cleaner body side. Never try to brush off dirt; brushing will force dirt into the fibers. Replace the paper air filter element if it is excessively dirty.

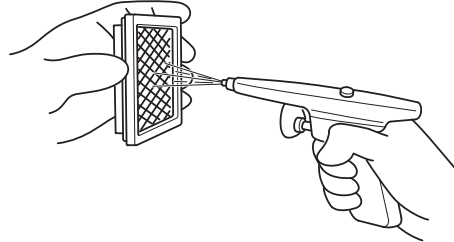
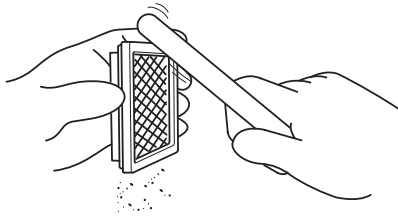

5. Reinstall the air cleaner element.
6. Reinstall the air cleaner cover and tighten the screw securely.

### 3. Cutting attachment replacement

#### Cutting blade:

##### **▲WARNING**

- To avoid severe personal injury, make sure that the engine switch is in the OFF position to prevent accidental starting.
- Use a genuine Honda replacement cutting blade.

##### **CAUTION:**

**Wear heavy gloves to protect your hands, when working around the cutting blade.**

1. Insert the tip of the 4 mm hexagon wrench (supplied with your trimmer) fully into the hole on the gear case.
2. Turn the cutting blade until you feel the tool drops into the hole in the internal locking ring. Verify the blade does not turn. The drive bolt and blade nut use left-hand threads. Make sure the 4 mm hexagon wrench remains in the hole, then loosen the blade nut (turns clockwise). Pay attention to the order and orientation of the parts as they are removed.

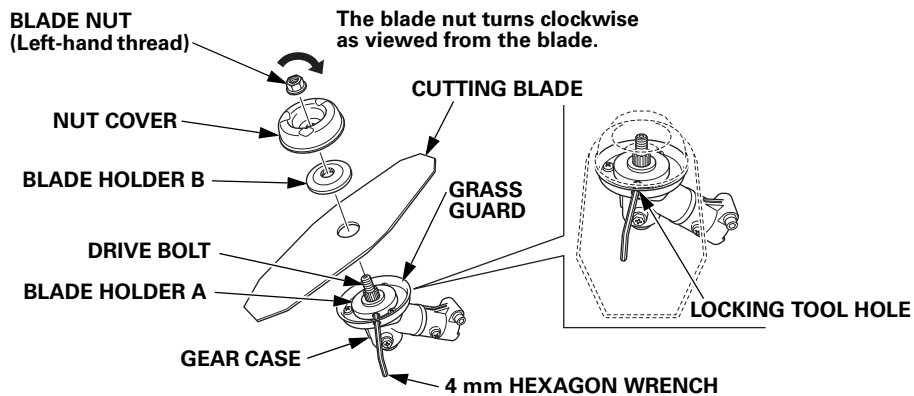

3. Installation can be performed in the reverse order of removal. Make sure you install the blade with the cutting edge in the direction of rotation. Torque the blade nut to: 24.0 N·m (2.5 kgf·m)
4. After tightening the blade nut, turn the cutting blade with your hand and check that it is installed in the center properly. Check the cutting blade is neither eccentric nor interfering with any neighboring part.

## 4. Grass deflector replacement

### **▲WARNING**

**Install the grass deflector in the proper position securely to protect you from the debris that are thrown from a wheeling cutting attachment.**

### **CAUTION:**

**Wear heavy gloves to protect your hands, when working around the cutting attachment.**

### **Installation position of grass deflector**

1. Place the grass deflector in a position that allows it to touch the gearbox.
2. Remove the grass deflector mounting bolts, and then remove the grass deflector.
3. Place the deflector holder on new grass deflector and align the bolt holes.
4. Keep the grass deflector position and direction same as below.  
Please avoid the distance between blade and deflector as recommend position to not touch or hit each other.
5. Tighten the bolts securely. Torque the bolts to: 6.9 N·m (0.7 kgf·m)

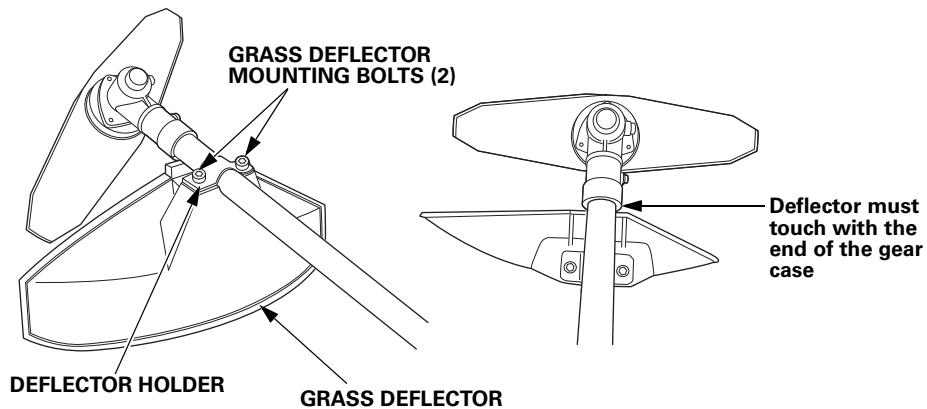

## 5. Spark plug service

**Recommended spark plug:** CMR5H (NGK)

To ensure proper engine operation, the spark plug must be properly gapped and free of deposits.

**▲WARNING**

**If the engine has been running, the muffler will be very hot, be careful not to touch the muffler.**

**CAUTION:**

**Never use a spark plug of incorrect heat range.**

1. Loosen the hex socket bolt with a 4mm hexagon wrench, then remove the top cover.
2. Remove the spark plug cap and use the proper size spark plug wrench to remove the spark plug.

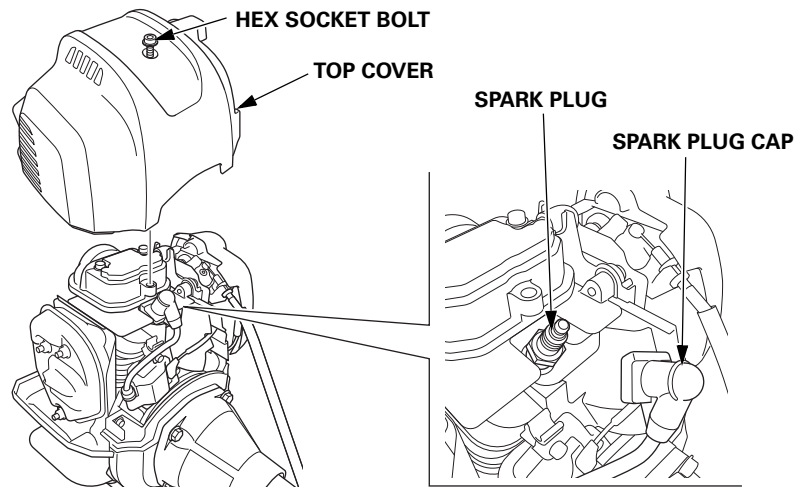

3. Visually inspect the spark plug. Discard it if there is apparent wear or the insulator is cracked or chipped. Clean the spark plug with a wire brush if it is to be reused.

4. Measure the plug gap with a feeler gauge.  
Correct as necessary by carefully bending the side electrode.  
The gap should be: 0.6 – 0.7 mm

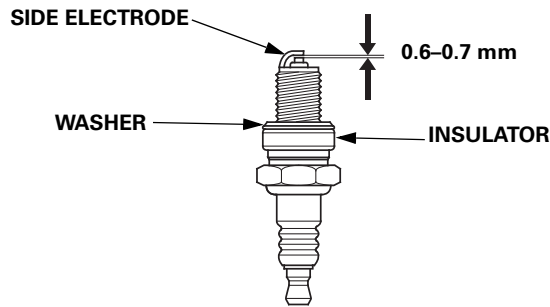

5. Check that the spark plug washer is in good condition and thread the spark plug in by hand to prevent cross-threading.
6. After the spark plug is seated, tighten with a spark plug wrench to compress the washer.

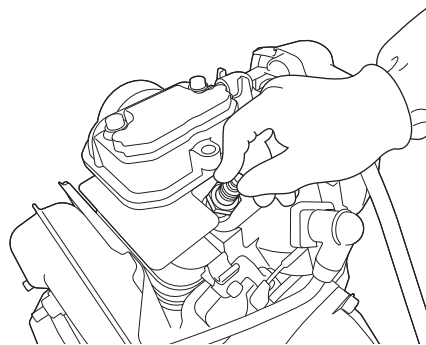

**NOTE:**

If installing a new spark plug, tighten 1/2 turn after the spark plug seats to compress the washer. If reinstalling a used spark plug, tighten 1/8 – 1/4 turn after the spark plug seats to compress the washer.

**TORQUE:** 11.8 N·m (1.2 kgf·m)

**CAUTION:**

**The spark plug must be securely tightened. An improperly tightened plug can become very hot and possibly damage the engine.**

7. Attach the spark plug cap.
8. Install the top cover, and tighten the hex socket bolt with a hexagon wrench securely.



## 6. Throttle cable check and adjustment

Adjust the throttle cable free play properly.

### Adjustment:

1. Move the choke lever to the CLOSED (upwards) position.
2. Loosen the screw and remove the air cleaner cover from the air cleaner body.

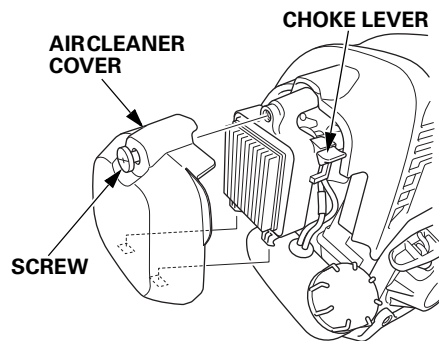

3. Loosen the throttle cable fixing nut.
4. Check the throttle cable free play at the tip of the cable by pulling and releasing the throttle trigger a few times and adjust the free play by using the adjusting nut. It should be 0.5 – 2.5 mm at the tip of the throttle cable. (Take care not to damage the throttle cable.)

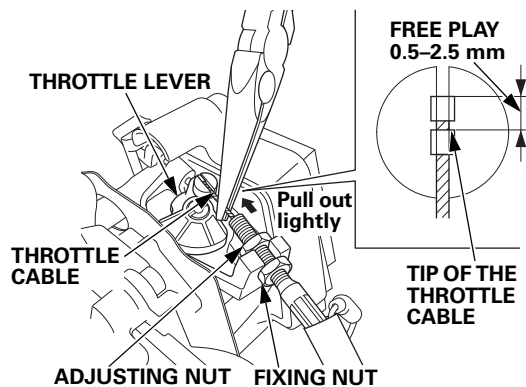

5. Tighten the throttle cable fixing nut securely.

6. Operate the throttle system several times and check it has the free play (i.e. throttle lever does not move while operating the throttle trigger).
7. After adjustment, check the throttle trigger for smooth operation. Consult your authorized Honda dealer if necessary.

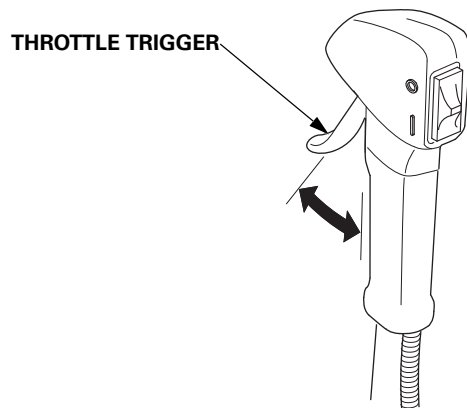

8. Reinstall the air cleaner cover and tighten the screw securely.

**CAUTION:**

- After removing the air cleaner cover, reinstall the air cleaner cover securely.  
Failure to tighten the cover securely may cause the cover to come out of position by vibration or some sort of engine malfunction.
- Operating the engine without the air cleaner or improperly installed air cleaner will allow dirt to enter the inside of the engine, causing adverse effect to the engine.

---

## 7. Engine cooling fin inspection

Inspect the cooling fin visually through the cover. If there are dry grass, leaves and mud clogged, consult your service dealer for cleaning it.

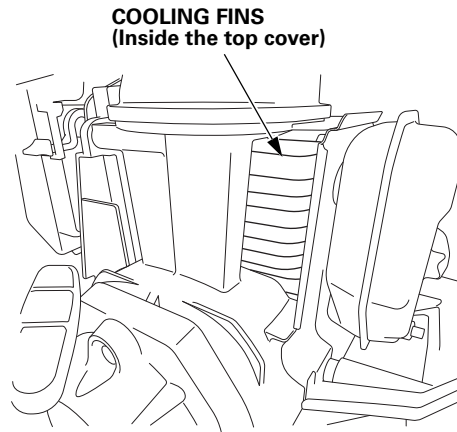

## 8. Fuel filter and fuel tank cleaning

Note that the clogged fuel filter can cause poor engine performance. Water and dust, dirt or contaminated material in the fuel tank cause a poor engine performance.

### **▲WARNING**

**Gasoline is extremely flammable and is explosive under certain conditions. You can be burned or seriously injured when handling fuel. Observe the following when servicing the fuel filter.**

- **Stop the engine.**
- **Service in a well-ventilated area.**
- **Keep heat, sparks, and flame away. Do not smoke.**
- **Do not spill the gasoline. If you spilled the gasoline, wipe it up immediately and dispose of the cloth or shop towel you wiped the spilled gasoline in a manner that is compatible with the environment.**

1. Be sure that the engine oil filler cap is tightened securely.
2. Remove the fuel tank cap and drain the gasoline into the container by tipping the engine toward the fuel filler neck.

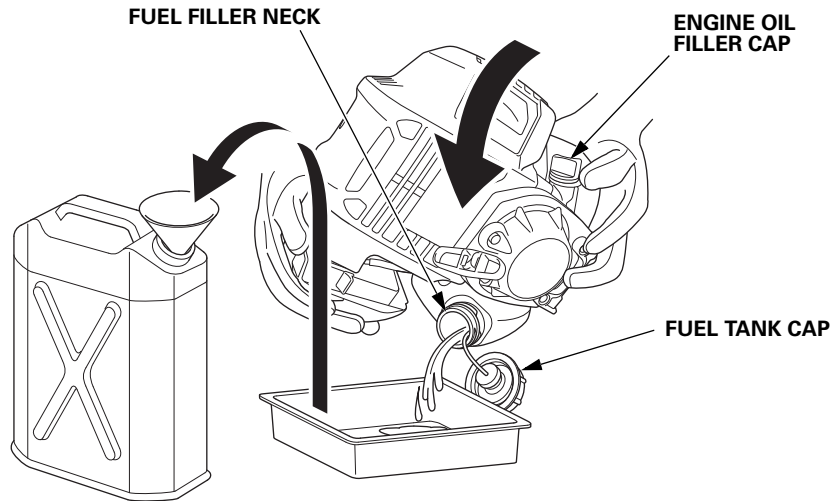

3. Pull out the fuel filter with the mechanic's wire from the fuel filler neck gently.

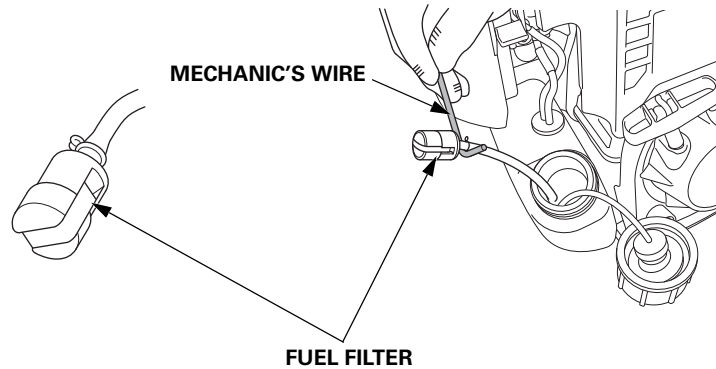

4. Inspect the fuel filter of its dirt. If the fuel filter is dirty, wash it gently with nonflammable or high flash point solvent. If the fuel filter is excessively dirty, replace it.
5. Remove water and dirt stood in the fuel tank by rinsing the inside of the fuel tank with nonflammable or high flash point solvent.
6. Return the fuel filter into the fuel tank and tighten the fuel tank cap securely.

## 9. Fuel tube check

Check fuel tubes for cracks and any other deterioration and confirm that there is no leakage of fuel on the fuel tubes. If you notice any abnormal symptoms on the fuel tubes, contact an authorized Honda dealer.

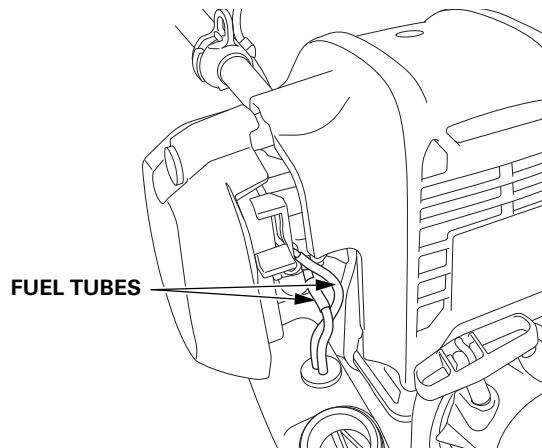

## 10. Grease of gear case

1. Remove the bolt of gear case.
  2. Apply the grease 15 - 20 g or full at the gear case.
  3. Install the bolt securely.
- Tighten the bolt securely. Torque the bolt to: 5.0 N·m (0.5 kgf·m)

 LEU HER ENTERPRISE CO., LTD. NE-XD-2 or EQUIVALENT (Lithium Complex Moly)

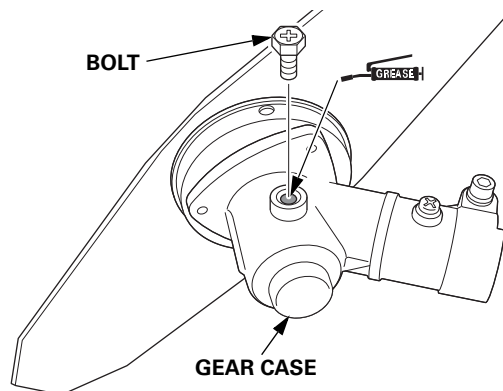

## 10. TRANSPORTING

### **CAUTION:**

**To avoid severe burns or fire hazards, let the engine cool before transporting the grass/weed trimmer.**

Always turn the engine switch to the OFF position. Make sure the fuel cap is securely tightened.

Carrying the grass/weed trimmer by hand:

Attach it to the carrying harness or hold the main pipe to carry it in a good balance.

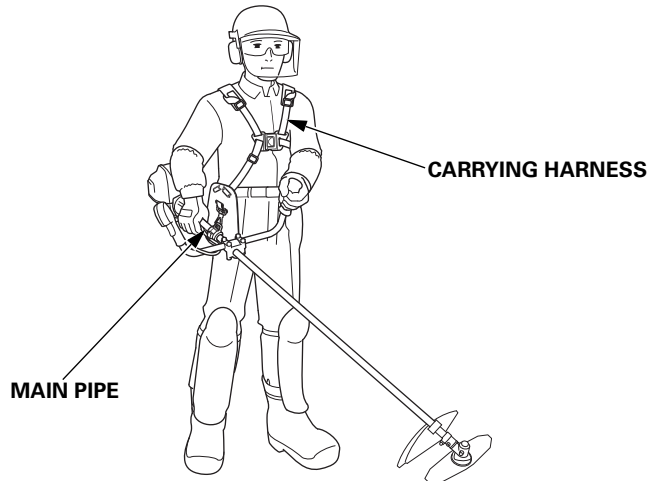

Transporting the grass/weed trimmer by vehicle:

Secure the grass/weed trimmer in level and make sure that it will not move or fall down.

## 11. STORAGE

Proper storage preparation is essential for keeping your grass/weed trimmer trouble free and looking good. The following steps will help to keep rust and corrosion from impairing your grass/weed trimmer.

### CAUTION:

- If the grass/weed trimmer has been running, the engine will be very hot; allow it to cool before proceeding.
- Place the grass/weed trimmer on a level surface and make sure that the engine switch is in the OFF position to be certain the engine will not start accidentally.

1. Clean all exterior surfaces, touch up any damaged paint, and coat other areas that may rust with a light film of oil.
2. Drain the fuel.

### ▲WARNING

**Gasoline is extremely flammable and explosive under certain conditions. Do not smoke or allow flames or sparks in the area.**

- a. Be sure that the engine oil filler cap is tightened securely.
- b. Remove the fuel tank cap and drain the fuel into the container by tipping the engine toward the fuel filler neck.

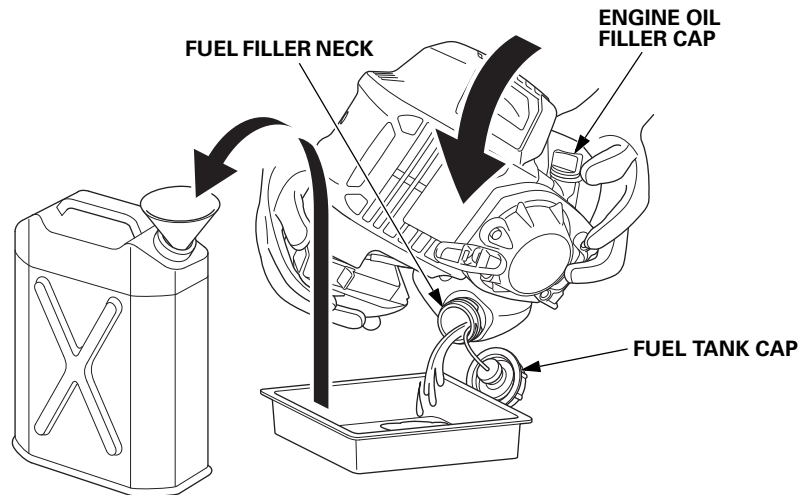



- c. Press the priming pump several times until all fuel has returned to the fuel tank.

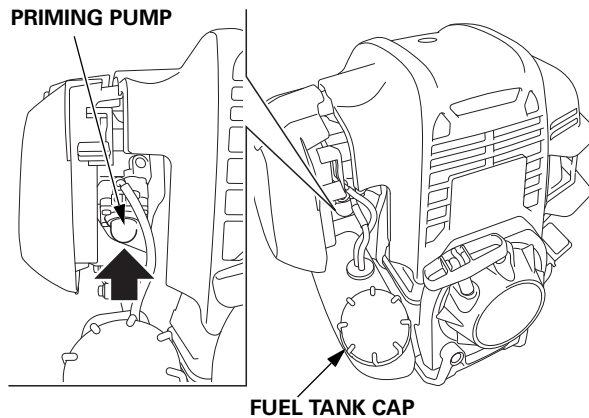

- d. Tip the engine toward the fuel filler neck again to drain the fuel left in the fuel tank into the container.  
e. Tighten the fuel tank cap securely after draining the fuel completely.

**NOTE:**

- Deteriorated gasoline may cause unexpected damage to your engine.
- Gasoline should be stored in a clean container used exclusively for gasoline.
- Gasoline should be stored in a cool and well ventilated place.
- Do not store or transport gasoline in PET [poly (ethylene terephthalate)] bottles.

3. Let the engine working until it stops because lack of fuel.

**CAUTION:**

**The engine will be very hot; allow it to cool before proceeding.**

4. Change the engine oil (see page 49).
5. Clean the air cleaner (see page 51).
6. Remove the top cover and remove the spark plug and pour about a tablespoon of clean engine oil into the cylinder.
7. Crank the engine several revolutions to distribute the oil, then reinstall the spark plug. Pull the starter grip slowly until resistance is felt. Reinstall the top cover.
8. Cover the grass/weed trimmer to keep out dust.

## 12. TROUBLESHOOTING

---

### When the engine will not start:

1. Is the engine switch in the ON position?
2. Is there fuel in the fuel tank (see page 23)?

**▲WARNING**

**Gasoline is extremely flammable and explosive under certain conditions. Do not smoke or allow flames or sparks in the area.**

3. Is gasoline reaching the carburetor?  
To check, press the priming pump several times (see page 38).
4. Is the spark plug in good condition?  
Clean, readjust gap and dry the spark plug. Replace it if necessary (see page 55).
5. If the engine still does not start, take the grass/weed trimmer to an authorized Honda dealer.

When an abnormal vibration occurs during operation, immediately turn off the engine and check the cutting attachment is properly installed and tightened securely, and inspect it for wear, crack or any other damage. If necessary, replace it (see page 31).

## 13. SPECIFICATIONS

MODEL	UMK450T
Power product description code	HAPT

### Frame

TYPE		U2TT
Handle type		U-shaped
Clutch type		Centrifugal clutch
Cutter	Type	2-teeth blade
	O.D.	350 mm
	Number of rotation (When engine rotation speed 7,000 rpm)	5,250 rpm
Overall length (With blade)		1,950 mm
Overall width		640 mm
Overall height		440 mm
Dry mass (weight) for unit (Without cutting attachment, engine oil and fuel)		8.2 kg

## Engine

MODEL	UMK450T
Engine model	GX50T
Engine description code	GCCFT
Engine type	4-stroke, overhead cam, 1 cylinder
Displacement	47.9 cm <sup>3</sup>
Bore and Stroke	43.0 x 33.0 mm
Engine Net power (in accordance with SAE J1349*)	1.47 kW/7,000 rpm
Engine max. Net torque (in accordance with SAE J1349*)	2.2 N·m/5,000 rpm
Idle speed	3,100 ± 200 rpm
Maximum speed when no load	MIN. 10,000 rpm
Cooling system	Forced air
Ignition system	Transistor magneto
Engine oil capacity	0.13 L
Fuel tank capacity	0.63 L
Spark plug	CMR5H (NGK)

\* The power rating of the engine indicated in this document is the net power output tested on a production engine for the engine model and measured in accordance with SAE J1349 at 7,000 rpm (Engine Net Power) and at 5,000 rpm (Engine Max. Net Torque). Mass production engines may vary from this value.

Actual power output for the engine installed in the final machine will vary depending on numerous factors, including the operating speed of the engine in application, environmental conditions, maintenance, and other variables.

### NOTE:

Specifications may vary according to the types, and are subject to change without notice.