

HONDA
POWER PRODUCTS

WATER PUMP WL20XH•WL30XH

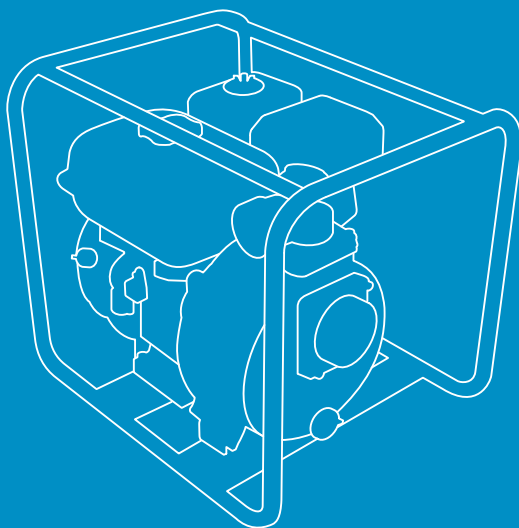

OWNER'S MANUAL

Keep this owner's manual handy so you can refer to it at any time. This owner's manual is considered a permanent part of the water pump and should remain with the water pump if resold.

The information and specifications included in this publication were in effect at the time of approval for printing. Honda Motor Co., Ltd. reserves the right, however, to discontinue or change specifications or design at any time without notice and without incurring any obligation whatever.

INTRODUCTION

Congratulations on your selection of a Honda water pump. We are certain you will be pleased with your purchase of one of the finest water pumps on the market.

We want to help you get the best results from your new water pump and to operate it safely. This manual contains the information on how to do that; please read it carefully.

As you read this manual, you will find information preceded by a **NOTICE** symbol. That information is intended to help you avoid damage to your water pump, other property, or the environment.

We suggest you read the warranty policy to fully understand its coverage and your responsibilities of ownership. The warranty policy is a separate document that should have been given to you by your dealer.

When your water pump needs scheduled maintenance, keep in mind that your Honda servicing dealer is specially trained in servicing Honda water pumps. Your Honda servicing dealer is dedicated to your satisfaction and will be pleased to answer your questions and concerns.

Best Wishes,
Honda Motor Co., Ltd.

INTRODUCTION

A FEW WORDS ABOUT SAFETY

Your safety and the safety of others are very important. And using this water pump safely is an important responsibility.

To help you make informed decisions about safety, we have provided operating procedures and other information on labels and in this manual. This information alerts you to potential hazards that could hurt you or others.

Of course, it is not practical or possible to warn you about all the hazards associated with operating or maintaining a water pump. You must use your own good judgment.

You will find important safety information in a variety of forms, including:

- **Safety Labels** — on the pump.
- **Safety Messages** — preceded by a safety alert symbol  and one of three signal words, DANGER, WARNING, or CAUTION.

These signal words mean:

 **DANGER**

You WILL be KILLED or SERIOUSLY HURT if you don't follow instructions.

 **WARNING**

You CAN be KILLED or SERIOUSLY HURT if you don't follow instructions.

 **CAUTION**

You CAN be HURT if you don't follow instructions.

- **Safety Headings** — such as *IMPORTANT SAFETY INFORMATION*.
- **Safety Section** — such as *PUMP SAFETY*.
- **Instructions** — how to use this pump correctly and safely.

This entire book is filled with important safety information — please read it carefully.

CONTENTS

PUMP SAFETY	5
IMPORTANT SAFETY INFORMATION	5
SAFETY LABEL LOCATION	7
CONTROLS & FEATURES	8
COMPONENT & CONTROL LOCATIONS	8
CONTROLS	10
Fuel Valve Lever	10
Engine Switch	10
Choke Lever	11
Throttle Lever	11
Starter Grip	12
FEATURES	12
Oil Alert System	12
BEFORE OPERATION	13
ARE YOU READY TO GET STARTED?	13
IS YOUR PUMP READY TO GO?	14
Check the General Condition of the Pump	14
Check the Suction and Discharge Hoses	15
Check the Engine	15
OPERATION	16
SAFE OPERATING PRECAUTIONS	16
PUMP PLACEMENT	17
SUCTION HOSE INSTALLATION	18
DISCHARGE HOSE INSTALLATION	19
PRIMING THE PUMP	19
STARTING THE ENGINE	20
SETTING ENGINE SPEED	22
STOPPING THE ENGINE	23
SERVICING YOUR PUMP	25
THE IMPORTANCE OF MAINTENANCE	25
MAINTENANCE SAFETY	26
MAINTENANCE SCHEDULE	27
REFUELING	28
FUEL RECOMMENDATION	29
ENGINE OIL LEVEL CHECK	30
ENGINE OIL CHANGE	31
ENGINE OIL RECOMMENDATION	32
AIR CLEANER INSPECTION	33

CONTENTS

AIR CLEANER CLEANING	34
SPARK PLUG SERVICE.....	36
STORAGE.....	38
STORAGE PREPARATION.....	38
Cleaning.....	38
Fuel.....	40
Engine Oil.....	42
STORAGE PRECAUTIONS	42
REMOVAL FROM STORAGE	43
TRANSPORTING	44
TAKING CARE OF UNEXPECTED PROBLEMS	45
ENGINE.....	45
Engine Will Not Start	45
Engine Lacks Power.....	45
PUMP	46
No Pump Output	46
Low Pump Output	46
TECHNICAL INFORMATION	47
SERIAL NUMBER LOCATION	47
CARBURETOR MODIFICATION FOR HIGH ALTITUDE	
OPERATION	48
SPECIFICATIONS	49

PUMP SAFETY

IMPORTANT SAFETY INFORMATION

Honda WL20XH and WL30XH pumps are designed to pump only fresh water that is not intended for human consumption, and other uses can result in injury to the operator or damage to the pump and other property.

Most injuries or property damage can be prevented if you follow all instructions in this manual and on the pump. The most common hazards are discussed below, along with the best way to protect yourself and others.

Operator Responsibility

It is the operator's responsibility to provide the necessary safeguards to protect people and property. Know how to stop the pump quickly in case of emergency. If you leave the pump for any reason, always turn the engine off. Understand the use of all controls and connections.

Be sure that anyone who operates the pump receives proper instruction. Do not let children operate the pump. Keep children and pets away from the area of operation.

Pump Operation

Pump only water that is not intended for human consumption. Pumping flammable liquids, such as gasoline or fuel oils, can result in a fire or explosion, causing serious injury. Pumping sea water, beverages, acids, chemical solutions, or any other liquid that promotes corrosion can damage the pump.

Refuel With Care

Gasoline is extremely flammable, and gasoline vapor can explode. Refuel outdoors, in a well ventilated area, with the engine stopped and the pump on a level surface. Do not fill the fuel tank above approximately 25 mm below the top of the fuel tank. Never smoke near gasoline, and keep other flames and sparks away. Always store gasoline in an approved container. Make sure that any spilled fuel has been wiped up before starting the engine.

PUMP SAFETY

Hot Exhaust

The muffler becomes very hot during operation and remains hot for a while after stopping the engine. Be careful not to touch the muffler while it is hot. Let the engine cool before transporting the pump or storing it indoors.

To prevent fire hazards, keep the pump at least 1 meter away from building walls and other equipment during operation. Do not place flammable objects close to the engine.

Carbon Monoxide Hazard

Exhaust gas contains poisonous carbon monoxide. Avoid inhalation of exhaust gas. Never run the engine in a closed garage or confined area.

SAFETY LABEL LOCATION

The label shown here contains important safety information. Please read it carefully. This label is considered a permanent part of your pump. If the label comes off or becomes hard to read, contact an authorized Honda servicing dealer for a replacement.

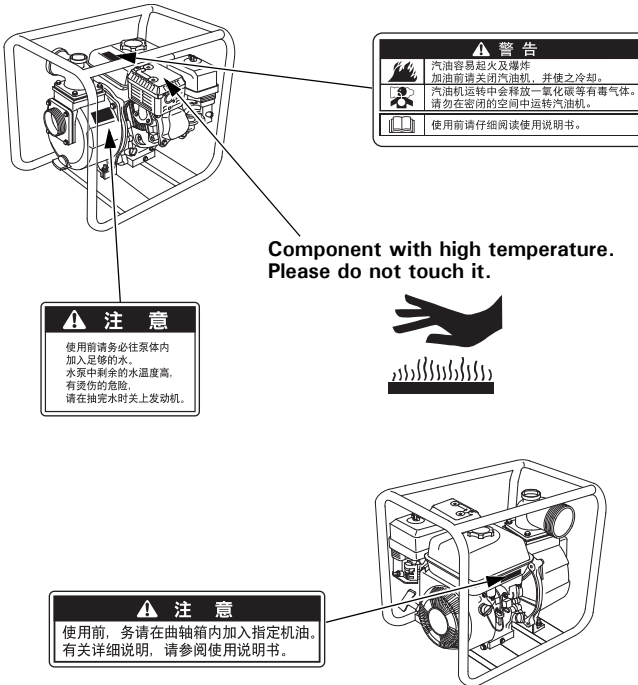

CONTROLS & FEATURES

COMPONENT & CONTROL LOCATIONS

<WL20XH>

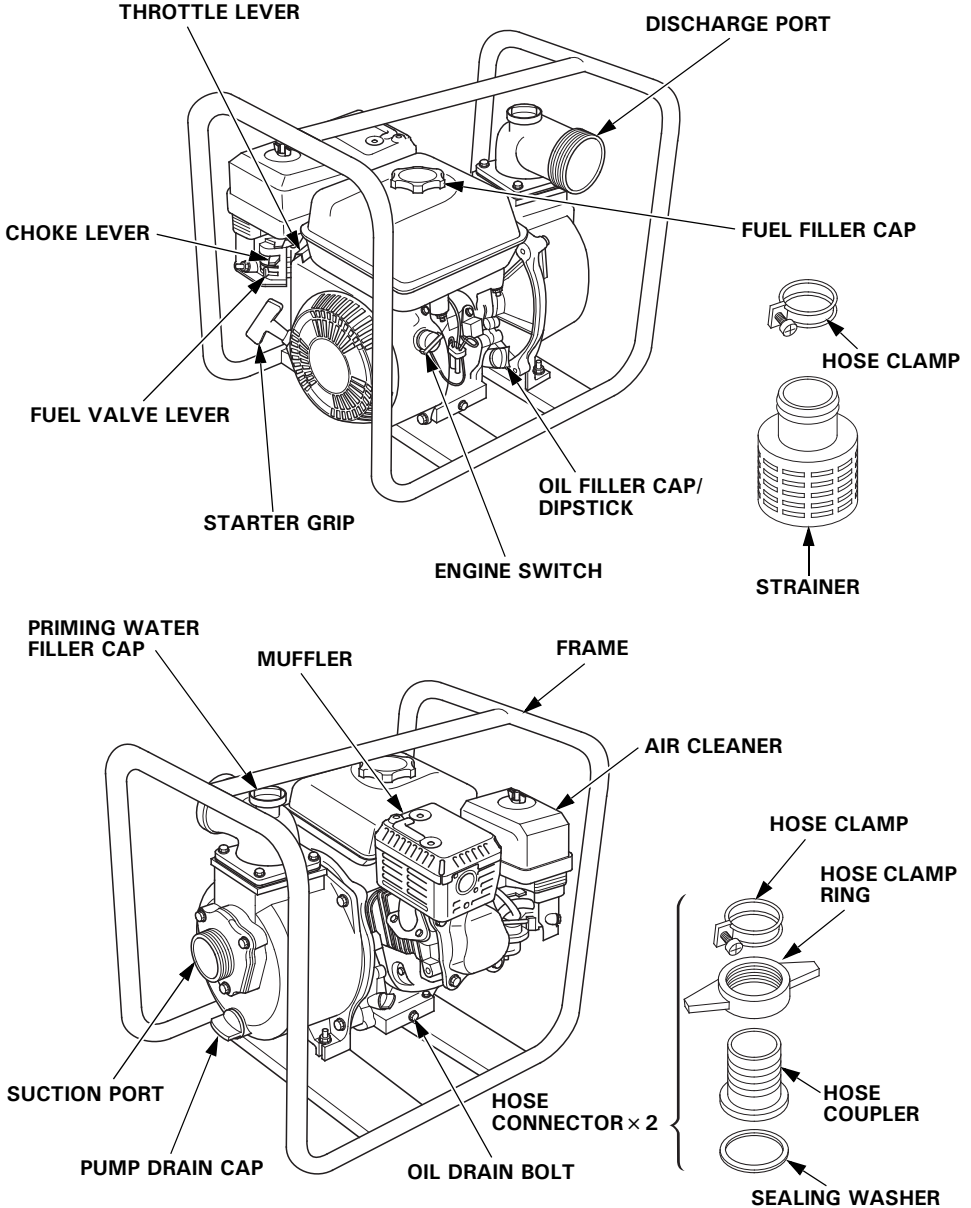

CONTROLS & FEATURES

<WL30XH>

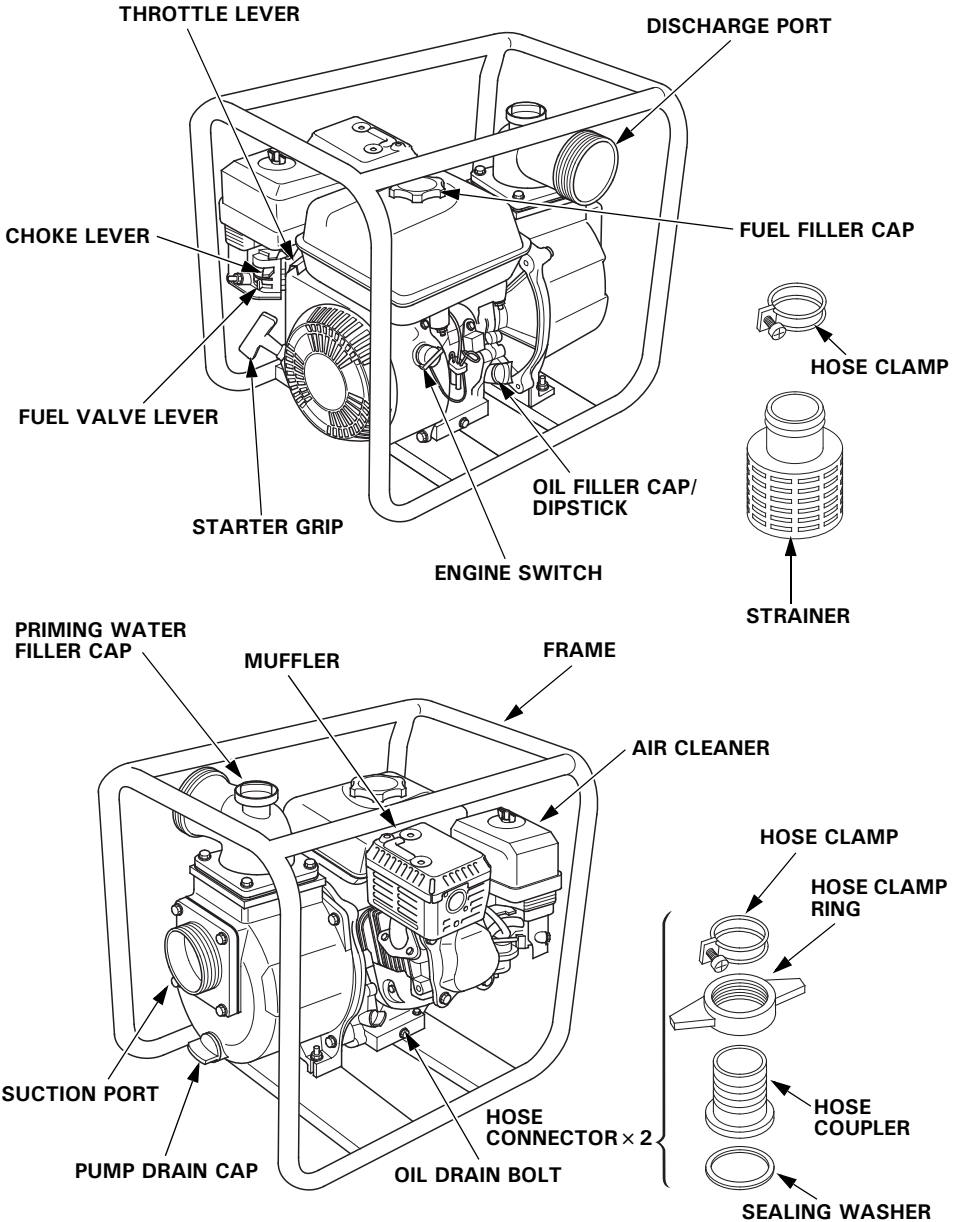

CONTROLS & FEATURES

CONTROLS

Fuel Valve Lever

The fuel valve opens and closes the passage between the fuel tank and the carburetor.

The fuel valve lever must be in the ON position for the engine to run.

When the engine is not in use, leave the fuel valve lever in the OFF position to prevent carburetor flooding and to reduce the possibility of fuel leakage.

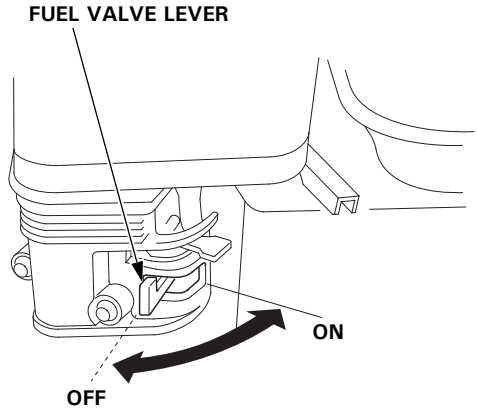

Engine Switch

The engine switch controls the ignition system.

The engine switch must be in the ON position for the engine to run.

Turning the engine switch to the OFF position stops the engine.

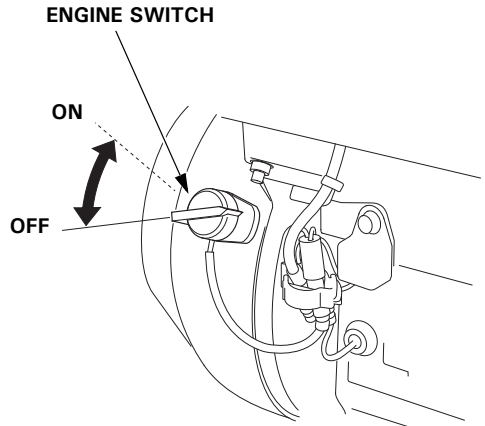

Choke Lever

The choke lever opens and closes the choke valve in the carburetor.

The CLOSED position enriches the fuel mixture for starting a cold engine.

The OPEN position provides the correct fuel mixture for operation after starting, and for restarting a warm engine.

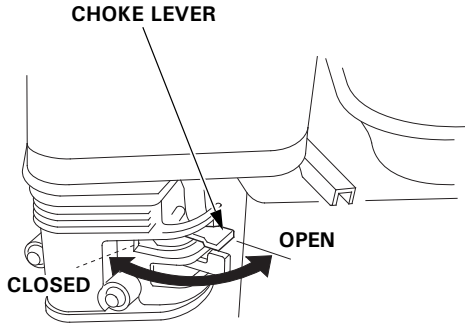

Throttle Lever

The throttle lever controls engine speed.

Moving the throttle lever in the directions shown makes the engine run faster or slower.

Pump output is controlled by adjusting the throttle lever. At maximum throttle position, the pump will deliver the highest output volume. Moving the throttle lever toward the idle position will decrease the output volume of the pump.

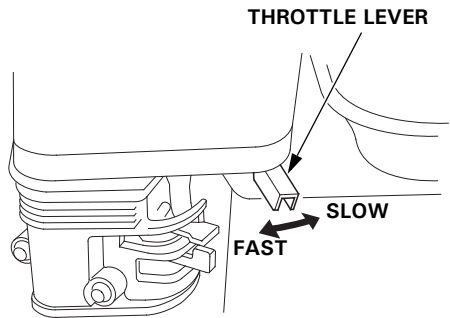

CONTROLS & FEATURES

Starter Grip

Pulling the starter grip operates the recoil starter to crank the engine for starting.

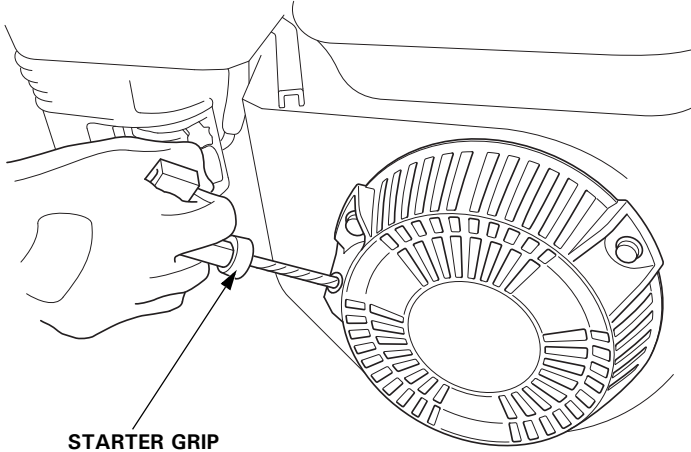

FEATURES

Oil Alert System

The Oil Alert system is designed to prevent engine damage caused by an insufficient amount of oil in the crankcase. Before the oil level in the crankcase can fall below a safe limit, the Oil Alert system will automatically stop the engine (the ignition switch will remain in the ON position).

If the engine stops and will not restart, check the engine oil level (page 30) before troubleshooting in other areas.

BEFORE OPERATION

ARE YOU READY TO GET STARTED?

Your safety is your responsibility. A little time spent in preparation will significantly reduce your risk of injury.

Knowledge

Read and understand this manual. Know what the controls do and how to operate them.

Familiarize yourself with the pump and its operation before you begin pumping. Know what to do in case of emergencies.

Be sure of what you are pumping. This pump is designed to pump only fresh water that is not intended for human consumption.

BEFORE OPERATION

IS YOUR PUMP READY TO GO?

For your safety, and to maximize the service life of your equipment, it is very important to take a few moments before you operate the pump to check its condition. Be sure to take care of any problem you find, or have your servicing dealer correct it, before you operate the pump.

⚠ WARNING

Improperly maintaining this pump, or failing to correct a problem before operation, could cause a malfunction in which you could be seriously injured.

Always perform a preoperation inspection before each operation, and correct any problem.

Exhaust gas contains poisonous carbon monoxide. Avoid inhalation of exhaust gas. Never run the engine in a closed garage or confined area.

To prevent fire hazards, keep the pump at least 1 meter away from building walls and other equipment during operation. Do not place flammable objects close to the engine.

Before beginning your preoperation checks, be sure the pump is on a level surface and the engine switch is in the OFF position.

Check the General Condition of the Pump

- Before each use, look around and underneath the engine for signs of oil or gasoline leaks.
- Remove any excessive dirt or debris, especially around the engine muffler and recoil starter.
- Look for signs of damage.
- Check that all nuts, bolts, screws, hose connectors and clamps are tightened.

Check the Suction and Discharge Hoses

- Check the general condition of the hoses. Be sure the hoses are in serviceable condition before connecting them to the pump. Remember that the suction hose must be reinforced construction to prevent hose collapse.
- Check that the sealing washer in the suction hose connector is in good condition (see page 18).
- Check that the hose connectors and clamps are securely installed (see pages 18 and 19).
- Check that the strainer is in good condition and is installed on the suction hose (see page 18).

Check the Engine

- Check the engine oil level (see page 30). Running the engine with a low oil level can cause engine damage.
- Check the air cleaner (see page 33). A dirty air cleaner will restrict air flow to the carburetor, reducing engine and pump performance.
- Check the fuel level (see page 28). Starting with a full tank will help to eliminate or reduce operating interruptions for refueling.

OPERATION

SAFE OPERATING PRECAUTIONS

To safely realize the full potential of this pump, you need a complete understanding of its operation and a certain amount of practice with its controls.

Before operating the pump for the first time, please review the *IMPORTANT SAFETY INFORMATION* on page 5 and the chapter titled *BEFORE OPERATION* (see page 13).

For your safety, avoid starting or operating the engine in an enclosed area, such as a garage. Your engine's exhaust contains poisonous carbon monoxide gas that can collect rapidly in an enclosed area and cause illness or death.

Pump only fresh water that is not intended for human consumption. Pumping flammable liquids, such as gasoline or fuel oils, can result in a fire or explosion, causing serious injury. Pumping sea water, beverages, acids, chemical solutions, or any other liquid that promotes corrosion can damage the pump.

PUMP PLACEMENT

For best pump performance, place the pump near the water level, and use hoses that are no longer than necessary. That will enable the pump to produce the greatest output with the least self priming time.

As head (pumping height) increases, pump output decreases. The length, type, and size of the suction and discharge hoses can also significantly affect pump output.

Discharge head capability is always greater than suction head capability, so it is important for suction head to be the shorter part of total head.

Minimizing suction head (placing the pump near the water level) is also very important for reducing self priming time. Self priming time is the time it takes the pump to bring water the distance of the suction head during initial operation.

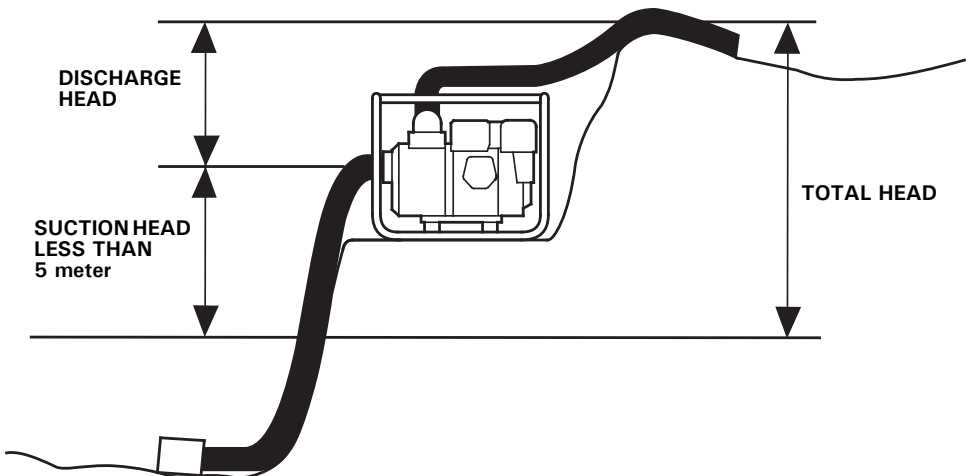

OPERATION

SUCTION HOSE INSTALLATION

Use a commercially available hose and hose connector with the hose clamp provided with the pump. The suction hose must be reinforced with a noncollapsible wall or braided wire construction.

Do not use a hose smaller than the pump's suction port size.
Minimum hose size: WL20XH = 50 mm
WL30XH = 80 mm

The suction hose should be no longer than necessary. Pump performance is best when the pump is near the water level and the hoses are short.

Use a hose clamp to securely fasten the hose connector to the suction hose in order to prevent air leakage and loss of suction. Verify that the hose connector sealing washer is in good condition.

Install the strainer (provided with the pump) on the other end of the suction hose, and secure it with a hose clamp. The strainer will help to prevent the pump from becoming clogged or damaged by debris.

Securely tighten the hose connector on the pump suction port.

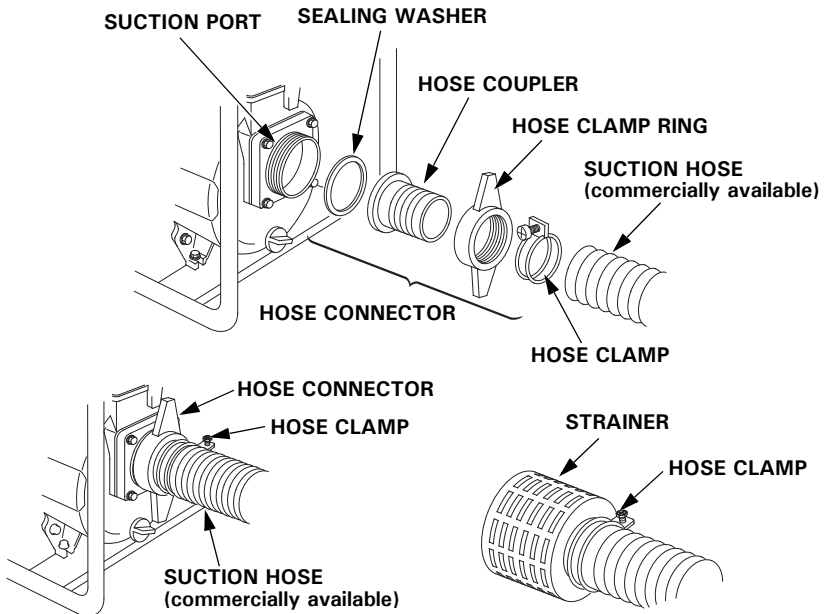

DISCHARGE HOSE INSTALLATION

Use a commercially available hose and hose connector, and clamp provided with the pump.

It is best to use a short, large-diameter hose, because that will reduce fluid friction and improve pump output. A long or small-diameter hose will increase fluid friction and reduce pump output.

Tighten the hose clamp securely to prevent the discharge hose from disconnecting under pressure.

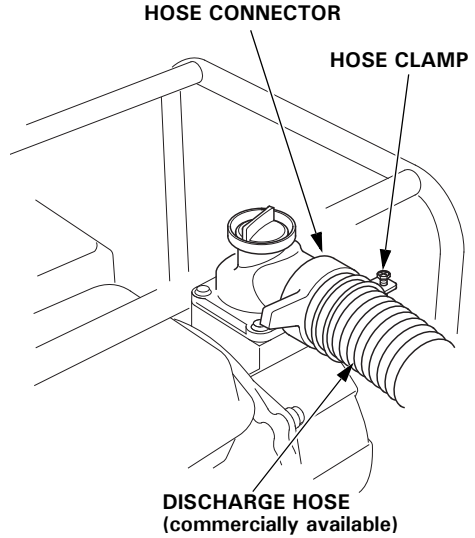

PRIMING THE PUMP

Before starting the engine, remove the filler cap from the pump chamber, and completely fill the pump chamber with water. Reinstall the filler cap and tighten it securely.

NOTICE

Operating the pump dry will destroy the pump seal. If the pump has been operated dry, stop the engine immediately, and allow the pump to cool before priming.

PRIMING WATER FILLER CAP

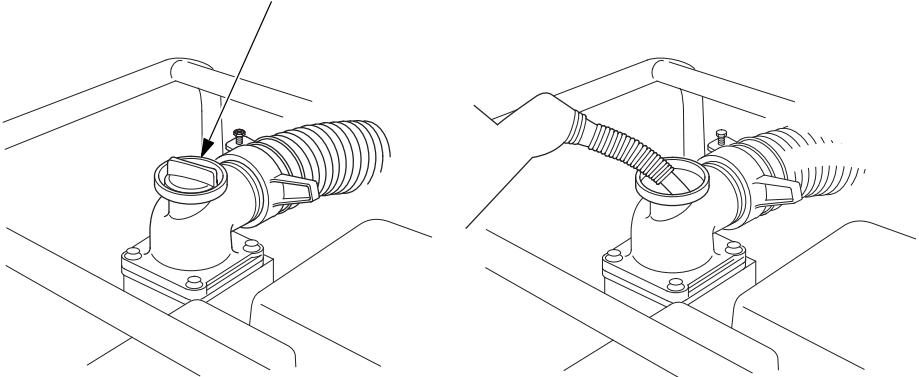

OPERATION

STARTING THE ENGINE

1. Prime the pump (see page 19).
2. Move the fuel valve lever to the ON position.

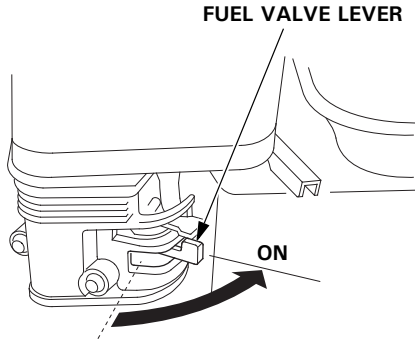

3. To start a cold engine, move the choke lever to the CLOSED position.
To restart a warm engine, leave the choke lever in the OPEN position.

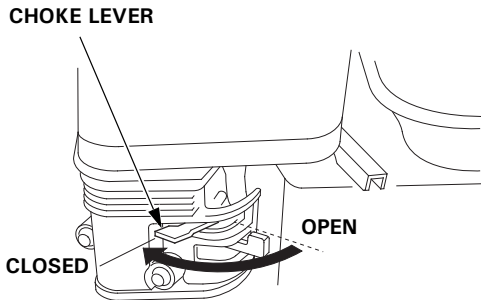

4. Move the throttle lever away from the SLOW position, about 1/3 of the way toward the FAST position.

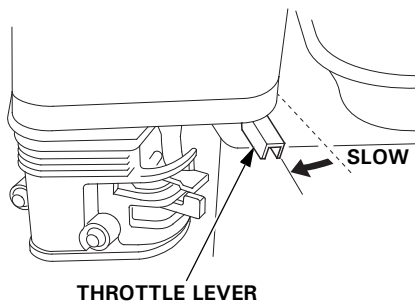

5. Turn the engine switch to the ON position.

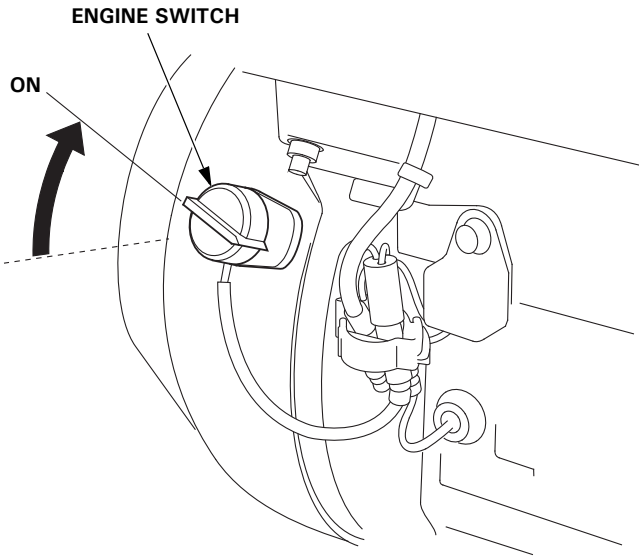

6. Pull the starter grip lightly until you feel resistance, then pull briskly in the direction of the arrow as shown below.

Do not allow the starter grip to snap back against the engine. Return it gently to prevent damage to the starter.

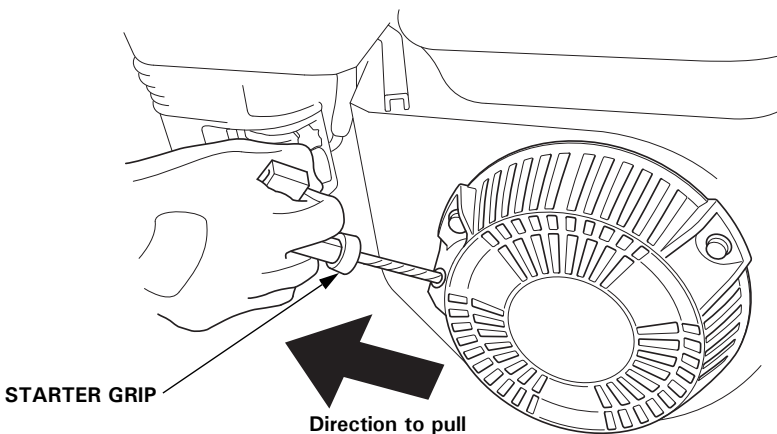

OPERATION

7. If the choke lever was moved to the CLOSED position to start the engine, gradually move it to the OPEN position as the engine warms up.

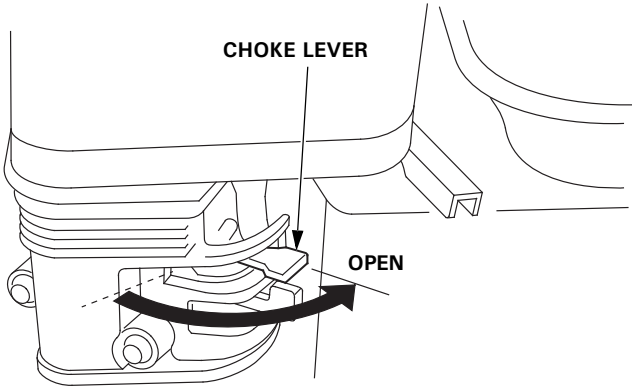

SETTING ENGINE SPEED

After starting the engine, move the throttle lever to the FAST position for self-priming, and check pump output.

Pump output is controlled by adjusting engine speed. Moving the throttle lever in the FAST direction will increase pump output, and moving the throttle lever in the SLOW direction will decrease pump output.

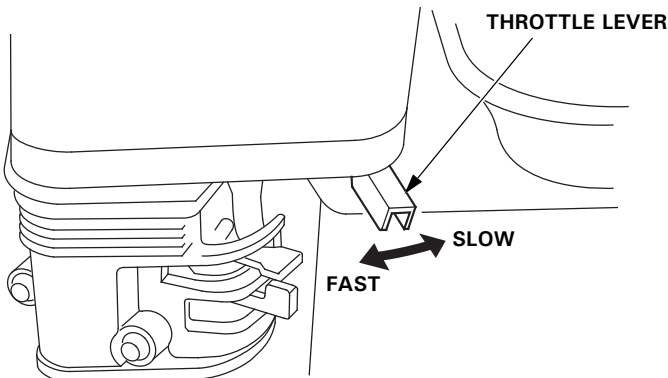

STOPPING THE ENGINE

To stop the engine in an emergency, simply turn the engine switch to the OFF position. Under normal conditions, use the following procedure.

1. Move the throttle lever to the SLOW position.

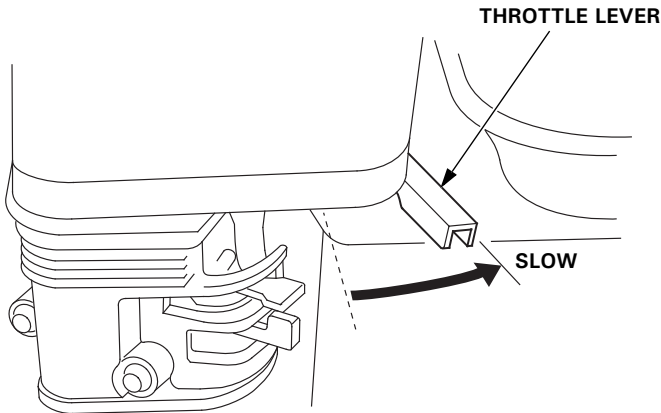

2. Turn the engine switch to the OFF position.

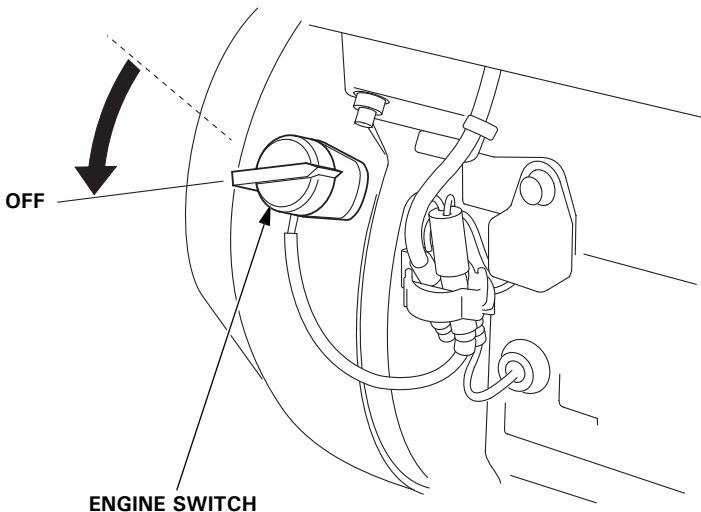

OPERATION

3. Turn the fuel valve lever to the OFF position.

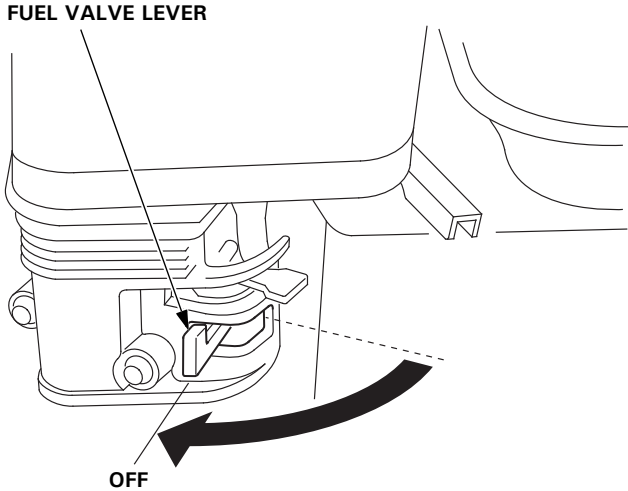

After use, remove the pump drain cap (see page 39), and drain the pump chamber. Remove the priming water filler cap, and flush the pump chamber with clean, fresh water. Allow the water to drain from the pump chamber, then reinstall the filler cap and drain cap.

SERVICING YOUR PUMP

THE IMPORTANCE OF MAINTENANCE

Good maintenance is essential for safe, economical, and trouble free operation. It will also help reduce air pollution.

⚠ WARNING

Improperly maintaining this pump, or failure to correct a problem before operation, can cause a malfunction in which you can be seriously hurt or killed.

Always follow the inspection and maintenance recommendations and schedules in this owner's manual.

To help you properly care for your pump, the following pages include a maintenance schedule, routine inspection procedures, and simple maintenance procedures using basic hand tools. Other service tasks that are more difficult, or require special tools, are best handled by professionals and are normally performed by a Honda technician or other qualified mechanic.

The maintenance schedule applies to normal operating conditions. If you operate your pump under severe conditions, such as sustained high load or high temperature operation, or use in unusually wet or dusty conditions, consult your servicing dealer for recommendations applicable to your individual needs and use.

Remember that an authorized Honda servicing dealer knows your pump best and is fully equipped to maintain and repair it.

To ensure the best quality and reliability, use only new, Honda Genuine parts or their equivalents for repair and replacement.

SERVICING YOUR PUMP

MAINTENANCE SAFETY

Some of the most important safety precautions follow. However, we cannot warn you of every conceivable hazard that can arise in performing maintenance. Only you can decide whether or not you should perform a given task.

⚠ WARNING

Failure to properly follow maintenance instructions and precautions can cause you to be seriously hurt or killed.

Always follow the procedures and precautions in the owner's manual.

Safety Precautions

- Make sure the engine is off before you begin any maintenance or repairs. This will eliminate several potential hazards:
 - **Carbon monoxide poisoning from engine exhaust.**
Be sure there is adequate ventilation whenever you operate the engine.
 - **Burns from hot parts.**
Let the engine and exhaust system cool before touching.
 - **Injury from moving parts.**
Do not run the engine unless instructed to do so.
- Read the instructions before you begin, and make sure you have the tools and skills required.
- To reduce the possibility of fire or explosion, be careful when working around gasoline. Use only a nonflammable solvent, not gasoline, to clean parts. Keep cigarettes, sparks, and flames away from all fuel related parts.

SERVICING YOUR PUMP

MAINTENANCE SCHEDULE

REGULAR SERVICE PERIOD (3) Perform at every indicated month or operating hour interval, whichever comes first.		Each use	First month or 20 hrs.	Every 3 months or 50 hrs.	Every 6 months or 100 hrs.	Every year or 300 hrs.
ITEM						
Engine oil	Check level	o				
	Change		o		o	
Air cleaner	Check	o				
	Clean				o (1)	
	Replace					o
Spark plug	Check-Adjust				o	
	Replace					o
Idle speed	Check-Adjust					o (2)
Valve clearance	Check-Adjust					o (2)
Combustion chamber	Clean	After every 500 hrs. (2)				
Fuel tank	Clean				o (2)	
Fuel tube	Check	Every 2 years (Replace if necessary) (2)				
Impeller	Check					o (2)
Impeller clearance	Check					o (2)
Pump inlet valve	Check					o (2)

(1) Service more frequently when used in dusty areas.

(2) These items should be serviced by your Honda servicing dealer, unless you have the proper tools and are mechanically proficient. Refer to the Honda shop manual for service procedures.

(3) For commercial use, log hours of operation to determine proper maintenance intervals.

SERVICING YOUR PUMP

REFUELING

With the engine stopped and on a level surface, remove the fuel filler cap and check the fuel level. Refill the tank if the fuel level is low.

⚠ WARNING

Gasoline is highly flammable and explosive.

You can be burned or seriously injured when handling fuel.

- Stop the engine and keep heat, sparks, and flame away.
- Handle fuel only outdoors.
- Wipe up spills immediately.

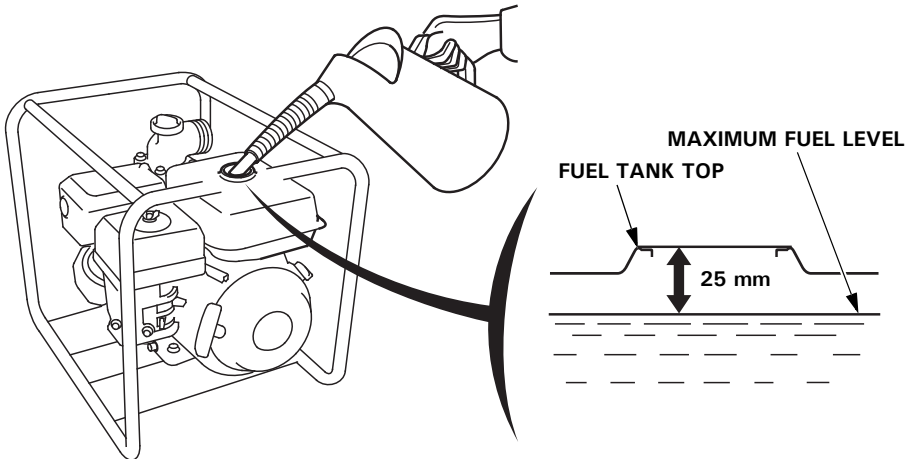

Refuel in a well ventilated area before starting the engine. If the engine has been running, allow it to cool. Refuel carefully to avoid spilling fuel. Do not fill the fuel tank completely. Fill tank to approximately 25 mm below the top of the fuel tank to allow for fuel expansion. If may be necessary to lower the fuel level depending on operating conditions. After refueling, tighten the fuel filler cap securely.

SERVICING YOUR PUMP

Never refuel the engine inside a building where gasoline fumes may reach flames or sparks. Keep gasoline away from appliance pilot lights, barbecues, electric appliances, power tools, etc.

Spilled fuel is not only a fire hazard, it causes environmental damage. Wipe up spills immediately.

NOTICE

Fuel can damage paint and plastic. Be careful not to spill fuel when filling your fuel tank. Damage caused by spilled fuel is not covered under warranty.

FUEL RECOMMENDATION

Use automotive unleaded gasoline with a Research Octane Number of 89 or higher.

Never use stale or contaminated gasoline or an oil/gasoline mixture. Avoid getting dirt or water in the fuel tank.

You may use regular unleaded gasoline containing no more than 10% ethanol (E10) or 5% methanol by volume. In addition, methanol must contain cosolvents and corrosion inhibitors.

Use of fuels with content of ethanol or methanol greater than shown above may cause starting and/or performance problems. It may also damage metal, rubber, and plastic parts of the fuel system.

Engine damage or performance problems that result from using a fuel with percentages of ethanol or methanol greater than shown above are not covered under warranty.

If your equipment will be used on an infrequent or intermittent basis, please refer to the fuel section of the *STORAGE* chapter (page 40) for additional information regarding fuel deterioration.

SERVICING YOUR PUMP

ENGINE OIL LEVEL CHECK

Check the engine oil level with the engine stopped and in a level position.

1. Remove the oil filler cap/dipstick and wipe it clean.
2. Insert and remove the dipstick without screwing it into the filler neck. Check the oil level shown on the dipstick.
3. If the oil level is low, fill to the edge of the oil filler hole with the recommended oil (see page 32).
4. Screw in the oil filler cap/dipstick securely.

OIL FILLER NECK

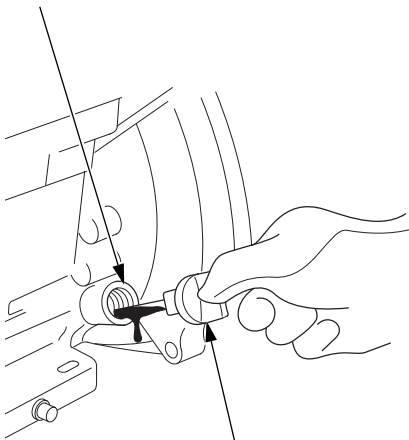

OIL FILLER CAP/DIPSTICK

UPPER LIMIT

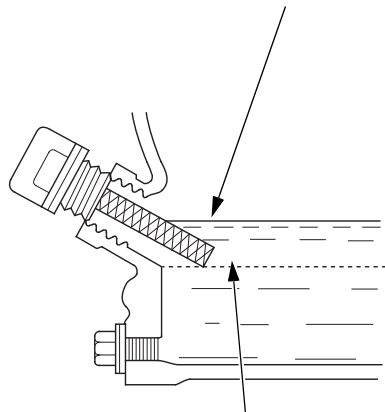

LOWER LIMIT

NOTICE

Running the engine with a low oil level can cause engine damage. This type of damage is not covered by the warranty.

ENGINE OIL CHANGE

Drain the used oil while the engine is warm. Warm oil drains quickly and completely.

1. Place a suitable container below the engine to catch the used oil, then remove the oil filler cap/dipstick, drain bolt and sealing washer.
2. Allow the used oil to drain completely, then reinstall the drain bolt, and sealing washer. Tighten the bolt securely.

Please dispose of used motor oil in a manner that is compatible with the environment. We suggest you take used oil in a sealed container to your local recycling center or service station for reclamation. Do not throw it in the trash, pour it on the ground, or pour it down a drain.

3. With the engine in a level position, fill to the edge of the oil filler hole with the recommended oil (see page 32).

Engine oil capacities: 0.58 L

NOTICE

Running the engine with a low oil level can cause engine damage. This type of damage is not covered by the warranty.

4. Screw in the oil filler cap/dipstick securely.

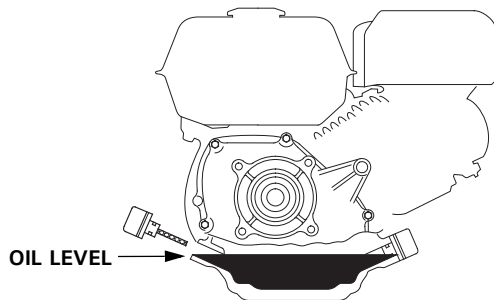
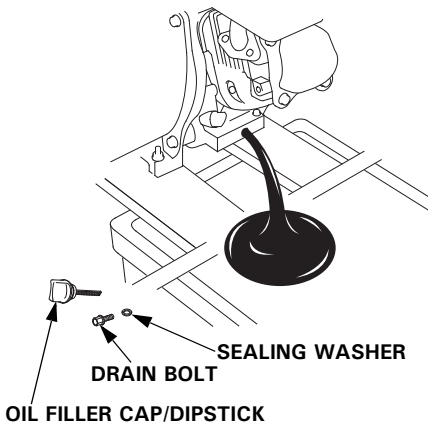

SERVICING YOUR PUMP

ENGINE OIL RECOMMENDATION

Oil is major factor affecting engine performance and service life. Use 4-stroke automotive detergent oil that meets or exceeds the requirements for API service category SE or later (or equivalent).

SAE 10W-30 is recommended for general use. Other viscosities shown in the chart may be used when the average temperature in your area is within the recommended range.

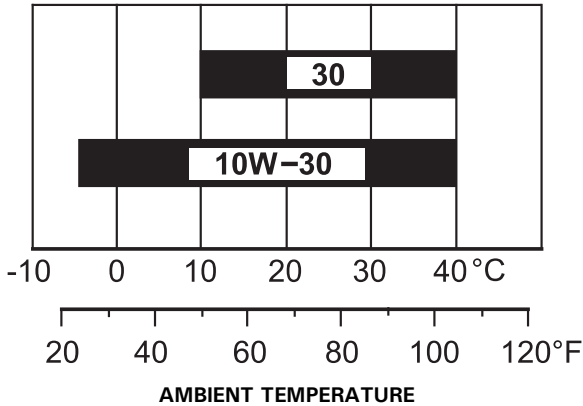

The SAE oil viscosity and service category are in the API label on the oil container. Honda recommends that you use API service category SE or later (or equivalent) oil.

AIR CLEANER INSPECTION

Unscrew the wing nut and remove the air cleaner cover. Check the filter elements to be sure they are clean and in good condition.

If the filter elements are dirty, clean or replace them as described on page 34. Replace the filter elements if they are damaged.

Reinstall the filter elements and air cleaner cover. Be sure all the parts shown below are in place. Tighten the wing nut securely.

NOTICE

Operating the engine without filter elements, or with a damaged filter elements, will allow dirt to enter the engine, causing rapid engine wear. This type of damage is not covered by the warranty.

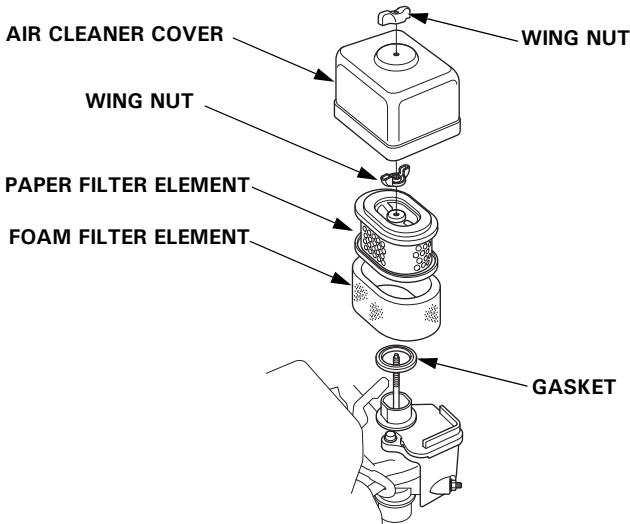

SERVICING YOUR PUMP

AIR CLEANER CLEANING

Dirty filter elements will restrict air flow to the carburetor, reducing engine performance. If you operate the pump in very dusty areas, clean the filter elements more frequently than specified in the MAINTENANCE SCHEDULE (see page 27).

1. Inspect both air filter elements, and replace them if they are damaged. Always replace the paper air filter element at the scheduled interval (see page 27).

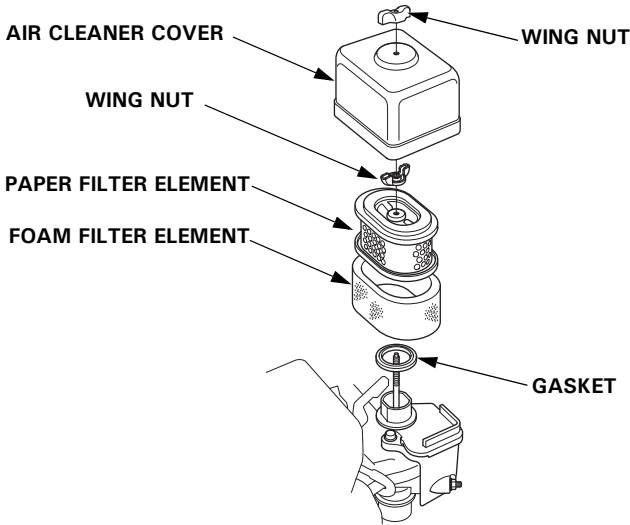

SERVICING YOUR PUMP

2. Clean the air filter elements if they are to be reused.

Paper filter element: Tap the filter element several times on a hard surface to remove dirt, or blow compressed air [not exceeding 207 kPa (2.1 kgf/cm²)] through the filter element from the inside. Never try to brush off dirt; brushing will force dirt into the fibers.

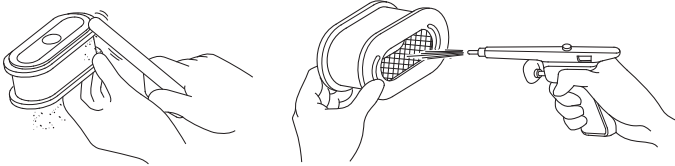

Foam filter element: Clean in warm soapy water, rinse, and allow to dry thoroughly. Or clean in non-flammable solvent and allow to dry. Dip the filter element in clean engine oil, and then squeeze out all excess oil. The engine will smoke when started if too much oil is left in the foam.

Clean

Squeeze and Dry

Dip in Oil

Squeeze

Do not twist.

Do not twist.

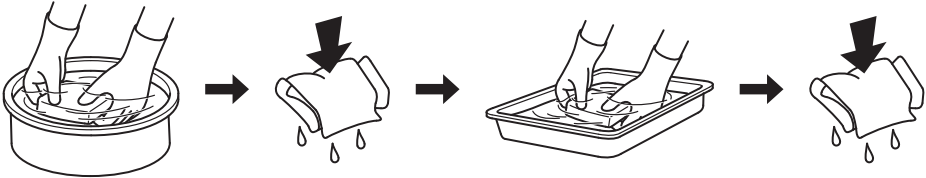

3. Wipe dirt from the air cleaner base and cover, using a moist rag. Be careful to prevent dirt from entering the air duct that leads to the carburetor.

SERVICING YOUR PUMP

SPARK PLUG SERVICE

In order to service the spark plug, you will need a spark plug wrench (commercially available).

Recommended spark plug: BPR6ES (NGK)
W20EPR-U (DENSO)

NOTICE

Incorrect spark plugs can cause engine damage.

1. Disconnect the spark plug cap, and remove any dirt from around the spark plug area.
2. Remove the spark plug with a spark plug wrench.

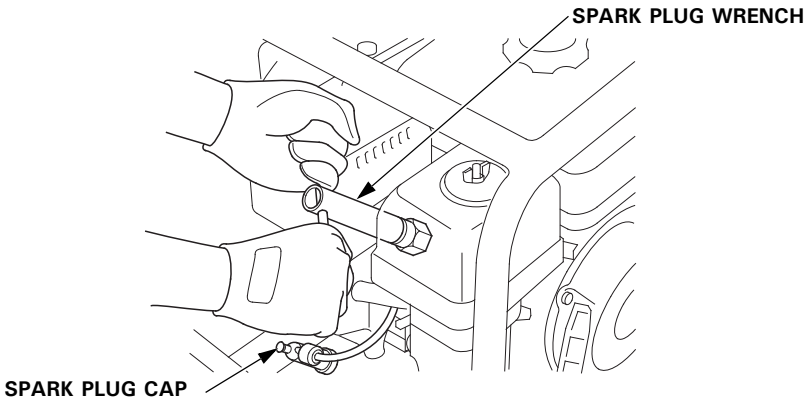

3. Inspect the spark plug. Replace it if the electrodes are worn, or if the insulator is cracked or chipped.

4. Measure the spark plug electrode gap with a wire type feeler gauge.

Correct the gap, if necessary, by carefully bending the side electrode.

The gap should be:
0.7–0.8 mm

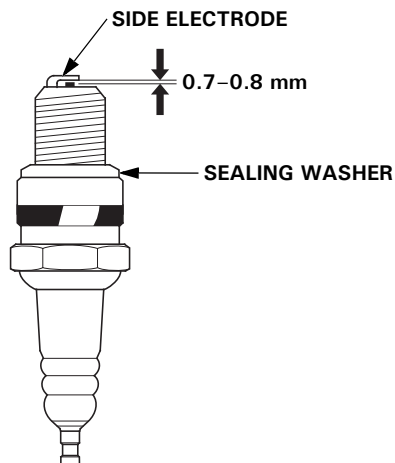

5. Install the spark plug carefully, by hand, to avoid cross threading.
6. After the spark plug seats, tighten with a spark plug wrench to compress the washer.

If reinstalling the used spark plug, tighten 1/8–1/4 turn after the spark plug seats.

If installing a new spark plug, tighten 1/2 turn after the spark plug seats.

NOTICE

*A loose spark plug can overheat and damage the engine.
Overtightening the spark plug can damage the threads in the cylinder head.*

7. Attach the spark plug cap.

STORAGE

STORAGE PREPARATION

Proper storage preparation is essential for keeping your pump trouble-free and looking good. The following steps will help to keep rust and corrosion from impairing your pump's function and appearance, and will make the engine easier to start when you use the pump again.

Cleaning

1. Wash the engine and pump.

Wash the engine by hand, and be careful to prevent water from entering the air cleaner or muffler opening. Keep water away from controls and all other places that are difficult to dry, as water promotes rust.

NOTICE

- *Using a garden hose or pressure washing equipment can force water into the air cleaner or muffler opening. Water in the air cleaner will soak the air cleaner, and water that passes through the air cleaner or muffler can enter the cylinder, causing damage.*
- *Water contacting a hot engine can cause damage. If the engine has been running, allow it to cool for at least half an hour before washing.*

2. Wipe dry all accessible surfaces.

3. Fill the pump chamber with clean, fresh water, start the engine outdoors, and let it run until it reaches normal operating temperature to evaporate any external water.

NOTICE

Dry operation will damage the pump seal. Be sure the pump chamber is filled with water before starting the engine.

4. Stop the engine, and allow it to cool.
5. Remove the pump drain cap, and flush the pump with clean, fresh water. Allow the water to drain from the pump chamber, then reinstall the drain cap.
6. After the pump is clean and dry, touch up any damaged paint, and coat areas that may rust with a light film of oil. Lubricate controls with a silicone spray lubricant.

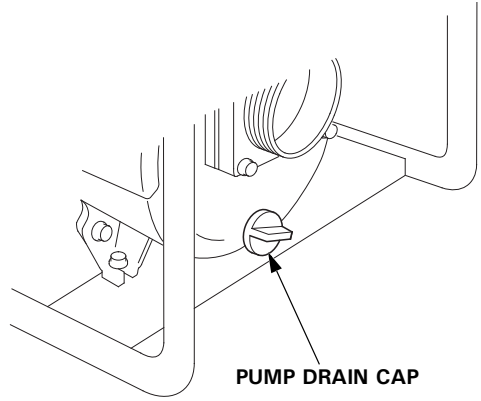

STORAGE

Fuel

NOTICE

Depending on the region where you operate your equipment, fuel formulations may deteriorate and oxidize rapidly. Fuel deterioration and oxidation can occur in as little as 30 days and may cause damage to the carburetor and/or fuel system. Please check with your servicing dealer for local storage recommendations.

Gasoline will oxidize and deteriorate in storage. Old gasoline will cause hard starting, and it leaves gum deposits that clog the fuel system. If the gasoline in your engine deteriorates during storage, you may need to have the carburetor and other fuel system components serviced or replaced.

The length of time that gasoline can be left in your fuel tank and carburetor without causing functional problems will vary with such factors as gasoline blend, your storage temperatures, and whether the fuel tank is partially or completely filled. The air in a partially filled fuel tank promotes fuel deterioration. Very warm storage temperatures accelerate fuel deterioration. Fuel deterioration problems may occur within a few months, or even less if the gasoline was not fresh when you filled the fuel tank.

Draining the Fuel Tank and Carburetor

⚠ WARNING

Gasoline is highly flammable and explosive.

You can be burned or seriously injured when handling fuel.

- Keep heat, sparks, and flame away.
- Handle fuel only outdoors.
- Wipe up spills immediately.

1. Move the fuel valve lever to the OFF position.
2. Remove the fuel tank cap and empty the fuel tank into an approved gasoline container. We recommend using a commercially available gasoline hand pump to empty the tank. Do not use an electric pump.
3. Place an approved gasoline container below the carburetor, and use a funnel to avoid spilling fuel.
4. Loosen the carburetor drain bolt by turning 1 to 2 turns counter clockwise, then move the fuel valve lever to the ON position.

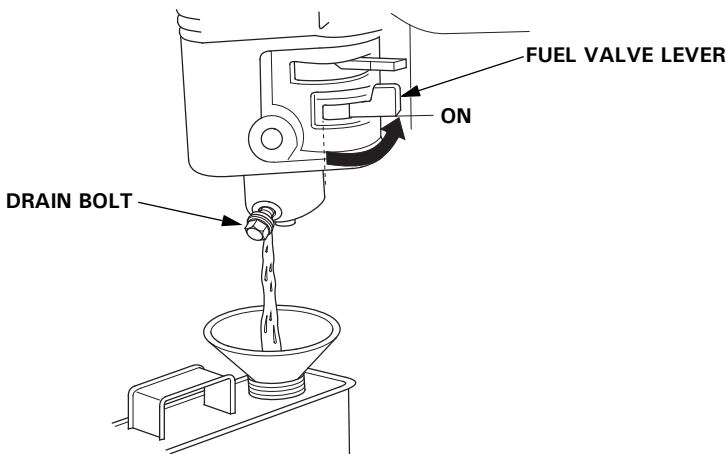

5. After all the fuel has drained into the container, then move the fuel valve lever to the OFF position. Tighten the drain bolt securely.

STORAGE

Engine Oil

1. Change the engine oil (see page 31).
2. Remove the spark plug (see page 36).
3. Pour a tablespoon (5–10 cm³/5–10 cc) of clean engine oil into the cylinder.
4. Pull the starter grip several times to distribute the oil in the cylinder.
5. Reinstall the spark plug.
6. Pull the starter grip slowly until resistance is felt. This will close the valves so moisture cannot enter the engine cylinder. Return the starter grip gently.

STORAGE PRECAUTIONS

If your pump will be stored with gasoline in the fuel tank and carburetor, it is important to reduce the hazard of gasoline vapor ignition. Select a well ventilated storage area away from any appliance that operates with a flame, such as a furnace, water heater, or clothes dryer. Also avoid any area with a spark producing electric motor or where power tools are operated.

If possible, avoid storage areas with high humidity, because that promotes rust and corrosion.

Unless all fuel has been drained from the fuel tank, leave the fuel valve lever in the OFF position to reduce the possibility of fuel leakage.

Place the pump on a level surface. Tilting can cause fuel or oil leakage.

With the engine and exhaust system cool, cover the pump to keep out dust. A hot engine and exhaust system can ignite or melt some materials. Do not use sheet plastic as a dust cover. A nonporous cover will trap moisture around the pump, promoting rust and corrosion.

REMOVAL FROM STORAGE

Check your pump as described in the *BEFORE OPERATION* chapter (see page 13) of this manual.

If the fuel was drained during storage preparation, fill the tank with fresh gasoline. If you keep a container of gasoline for refueling, be sure that it contains only fresh gasoline. Gasoline oxidizes and deteriorates over time, causing hard starting.

If the cylinder was coated with oil during storage preparation, the engine may smoke briefly at startup. This is normal.

TRANSPORTING

If the pump has been running, allow the engine to cool for at least 15 minutes before loading the pump on the transport vehicle. A hot engine and exhaust system can burn you and can ignite some materials.

Keep the pump level when transporting to reduce the possibility of fuel leakage. Move the fuel valve lever to the OFF position.

TAKING CARE OF UNEXPECTED PROBLEMS

ENGINE

Engine Will Not Start

Possible Cause	Correction
Fuel valve OFF.	Move fuel valve lever to ON position.
Choke open.	Move choke lever to CLOSED position unless engine is warm.
Ignition switch OFF.	Turn ignition switch to ON.
Out of fuel.	Refuel (p. 28)
Bad fuel; pump stored without treating or draining gasoline, or refueled with bad gasoline.	Drain fuel tank and carburetor (p. 41). Refuel with fresh gasoline (p. 28).
Low oil level caused Oil Alert to stop engine.	Add oil (p. 30)
Spark plug faulty, fouled, or improperly gapped.	Clean, gap, or replace spark plug (p. 36).
Spark plug wet with fuel (flooded engine).	Dry and install spark plug. Start engine with throttle lever in FAST position.
Carburetor malfunction, ignition malfunction, valves stuck, etc.	Take engine to an authorized Honda servicing dealer, or refer to shop manual.

Engine Lacks Power

Possible Cause	Correction
Air filter clogged.	Clean or replace filter (p. 34).
Bad fuel; pump stored without treating or draining gasoline, or refueled with bad gasoline.	Drain fuel tank and carburetor (p. 41). Refuel with fresh gasoline (p. 28).
Throttle lever in slow position.	Move throttle to the FAST position.
Carburetor malfunction, ignition malfunction, valves stuck, etc.	Take engine to an authorized Honda servicing dealer, or refer to shop manual.

TAKING CARE OF UNEXPECTED PROBLEMS

PUMP

No Pump Output

Possible Cause	Correction
Pump not primed.	Prime pump (p. 19)
Hose collapsed, cut or punctured.	Replace suction hose (p. 18).
Strainer not completely underwater.	Sink the strainer and the end of the suction hose completely underwater.
Air leak at connector.	Replace sealing washer if missing or damaged. Tighten hose connector and clamp (p. 18).
Strainer clogged.	Clean debris from strainer.
Excessive head.	Relocate pump and/or hoses to reduce head (p. 17).
Engine speed too slow.	Move throttle to fast.

Low Pump Output

Possible Cause	Correction
Hose collapsed, damaged, too long, or diameter too small.	Replace suction hose (p. 18).
Air leak at connector.	Replace sealing washer if missing or damaged. Tighten hose connector and clamp (p. 18).
Strainer clogged.	Clean debris from strainer.
Hose damaged, too long, or diameter too small.	Replace discharge hose (p. 19).
Marginal head.	Relocate pump and/or hoses to reduce head (p. 17).
Engine speed too slow.	Move throttle to fast.

TECHNICAL INFORMATION

SERIAL NUMBER LOCATION

< WL20XH >

< WL30XH >

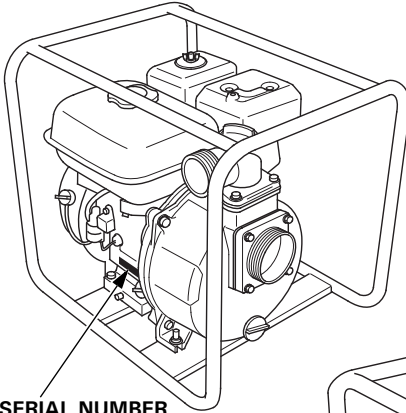

ENGINE SERIAL NUMBER

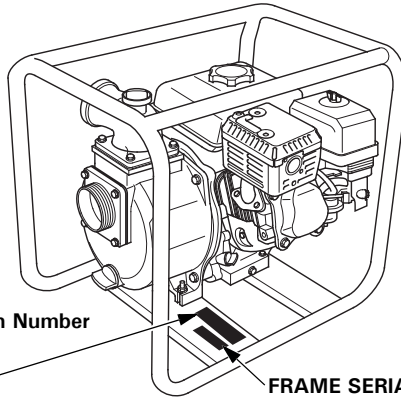

FRAME SERIAL NUMBER

< Example: WL20XH >
Machine Environmental Identification Number
Display method: Marking
Sample: *644620160H2000001*

Record the engine and frame serial numbers and date purchased in the spaces below. You will need these information when ordering parts, and when making technical or warranty inquiries.

Machine Environmental Identification Number: _____

Engine serial number: _____

Frame serial number: _____

Date purchased: _____

TECHNICAL INFORMATION

CARBURETOR MODIFICATION FOR HIGH ALTITUDE OPERATION

At high altitude, the standard carburetor air-fuel mixture will be too rich. Performance will decrease, and fuel consumption will increase. A very rich mixture will also foul the spark plug and cause hard starting. Operation at an altitude that differs from that at which this engine was certified, for extended periods of time, may increase emissions.

High altitude performance can be improved by specific modifications to the carburetor. If you always operate your pump at altitudes above 1,500 meters, have your servicing dealer perform this carburetor modification. This engine, when operated at high altitude with the carburetor modifications for high altitude use, will meet each emission standard throughout its useful life.

Even with carburetor modification, engine horsepower will decrease about 3.5% for each 300-meter increase in altitude. The effect of altitude on horsepower will be greater than this if no carburetor modification is made.

NOTICE

When the carburetor has been modified for high altitude operation, the air-fuel mixture will be too lean for low altitude use. Operation at altitudes below 1,500 meters with a modified carburetor may cause the engine to overheat and result in serious engine damage. For use at low altitudes, have your servicing dealer return the carburetor to original factory specifications.

SPECIFICATIONS

WL20XH

Dimensions and weight

Length	490 mm
Width	385 mm
Height	410 mm
Dry mass [weight]	24 kg

Engine design and performance

Model	GP160
Engine type	4-stroke, overhead valve, single cylinder
Displacement [Bore × Stroke]	163 cm ³ [68.0 × 45.0 mm]
Fuel tank capacity	3.1 L
Engine Net power	3.05 kW (4.1 PS) at 3,600 rpm
Engine Max. Net torque	10.3 N·m (1.05 kgf·m) at 2,500 rpm
Cooling system	Forced air
Ignition system	Transistorized magneto
PTO shaft rotation	Counterclockwise

TECHNICAL INFORMATION

WL20XH (continued)

Pump

Suction port diameter	50 mm
Discharge port diameter	50 mm
Total head (maximum)	22.8 m
Suction head (maximum)	5 m
Discharge capacity (maximum)	25.2 m ³ per hour
Self-priming time	110 seconds (maximum) at 5 m
Continuous running time	Approximately 2 h 6 min (actual time varies with pump load)

WL30XH

Dimensions and weight

Length	510 mm
Width	385 mm
Height	435 mm
Dry mass [weight]	25 kg

Engine design and performance

Model	GP160
Engine type	4-stroke, overhead valve, single cylinder
Displacement [Bore × Stroke]	163 cm ³ [68.0 × 45.0 mm]
Fuel tank capacity	3.1 L
Engine Net power	3.05 kW (4.1 PS) at 3,600 rpm
Engine Max. Net torque	10.3 N·m (1.05 kgf·m) at 2,500 rpm
Cooling system	Forced air
Ignition system	Transistorized magneto
PTO shaft rotation	Counterclockwise

TECHNICAL INFORMATION

WL30XH (continued)

Pump

Suction port diameter	80 mm
Discharge port diameter	80 mm
Total head (maximum)	15.8 m
Suction head (maximum)	5 m
Discharge capacity (maximum)	39.6 m ³ per hour
Self-priming time	150 seconds (maximum) at 5 m
Continuous running time	Approximately 1 h 54 min (actual time varies with pump load)

