

INTRODUCTION

Thank you for purchasing a Honda engine! We want to help you to get the best results from your new engine and to operate it safely. This manual contains information on how to do that; please read it carefully before operating the engine. If a problem should arise, or if you have any questions about your engine, consult an authorized Honda servicing dealer.

All information in this publication is based on the latest product information available at the time of printing. Honda Motor Co., Ltd. reserves the right to make changes at any time without notice and without incurring any obligation. No part of this publication may be reproduced without written permission.

This manual should be considered a permanent part of the engine and should remain with the engine if resold.

Review the instructions provided with the equipment powered by this engine for any additional information regarding engine startup, shutdown, operation, adjustments or any special maintenance instructions.

United States, Puerto Rico, and U.S. Virgin Islands:

We suggest you read the warranty policy to fully understand its coverage and your responsibilities of ownership. The warranty policy is a separate document that should have been given to you by your dealer.

SAFETY MESSAGES

Your safety and the safety of others are very important. We have provided important safety messages in this manual and on the engine. Please read these messages carefully.

A safety message alerts you to potential hazards that could hurt you or others. Each safety message is preceded by a safety alert symbol  and one of three words, DANGER, WARNING, or CAUTION.

These signal words mean:

 **DANGER** You WILL be KILLED or SERIOUSLY HURT if you don't follow instructions.

 **WARNING** You CAN be KILLED or SERIOUSLY HURT if you don't follow instructions.

 **CAUTION** You CAN be HURT if you don't follow instructions.

Each message tells you what the hazard is, what can happen, and what you can do to avoid or reduce injury.

DAMAGE PREVENTION MESSAGES

You will also see other important messages that are preceded by the word NOTICE.

This word means:

 **NOTICE** Your engine, other property, or the environment can be damaged if you don't follow instructions.

This entire book is filled with important safety information – please read it carefully.

©2019 Honda Motor Co., Ltd. –All Rights Reserved

iGX700 · iGX800

37ZEA601
00X37-ZEA-6010

HONDA



OWNER'S MANUAL

MANUEL DE L'UTILISATEUR

MANUAL DEL PROPIETARIO

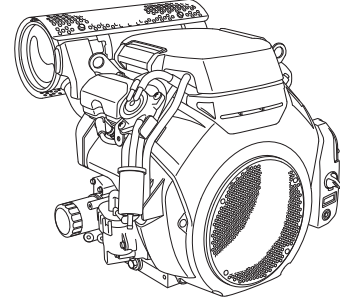
iGX700 • iGX800



 **WARNING:** 
The engine exhaust from this product contains chemicals known to the State of California to cause cancer, birth defects or other reproductive harm.

CONTENTS

INTRODUCTION.....	1	SPARK PLUG.....	10
SAFETY MESSAGES.....	1	SPARK ARRESTER.....	10
SAFETY INFORMATION.....	2	HELPFUL TIPS & SUGGESTIONS.....	11
SAFETY LABEL LOCATION.....	2	STORING YOUR ENGINE.....	11
COMPONENT & CONTROL LOCATION.....	3	TRANSPORTING.....	12
FEATURES.....	3	TAKING CARE OF UNEXPECTED PROBLEMS.....	12
BEFORE OPERATION CHECKS.....	4	FUSE REPLACEMENT.....	13
OPERATION.....	4	TECHNICAL INFORMATION.....	13
SAFE OPERATING PRECAUTIONS.....	4	Serial Number Location.....	13
STARTING THE ENGINE.....	5	Battery Connections for Electric Starter.....	14
STOPPING THE ENGINE.....	5	Emission Control System Information.....	14
SETTING ENGINE SPEED.....	6	Air Index.....	15
SERVICING YOUR ENGINE.....	6	Specifications.....	16
THE IMPORTANCE OF MAINTENANCE.....	6	Tuneup Specifications.....	16
MAINTENANCE SAFETY.....	6	Quick Reference Information.....	16
SAFETY PRECAUTIONS.....	7	Wiring Diagrams.....	17
MAINTENANCE SCHEDULE.....	7	CONSUMER INFORMATION.....	18
REFUELING.....	7	Warranty and Distributor/Dealer Locator Information.....	18
Recommended Fuel.....	7	Customer Service Information.....	18
ENGINE OIL.....	8		
Recommended Oil.....	8		
Oil Level Check.....	8		
Oil Change.....	8		
AIR CLEANER.....	9		
Inspection.....	9		
Cleaning.....	9		

ENGLISH

FRANÇAIS

ESPAÑOL

SAFETY INFORMATION

- Understand the operation of all controls and learn how to stop the engine quickly in case of emergency. Make sure the operator receives adequate instruction before operating the equipment.
- Do not allow children to operate the engine. Keep children and pets away from the area of operation.
- Your engine's exhaust contains poisonous carbon monoxide. Do not run the engine without adequate ventilation, and never run the engine indoors.
- The engine and exhaust become very hot during operation. Keep the engine at least 1 meter (3 feet) away from buildings and other equipment during operation. Keep flammable materials away, and do not place anything on the engine while it is running.

SAFETY LABEL LOCATION

This label warns you of potential hazards that can cause serious injury. Read it carefully.

If the label comes off or becomes hard to read, contact your servicing dealer for replacement.

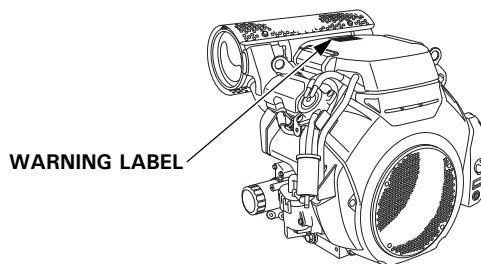

WARNING LABEL	For EU	Except EU
	attached to product	supplied with product
<p>⚠ WARNING</p> <p>Gasoline is highly flammable and explosive. Turn engine off and let cool before refueling. The engine emits toxic carbon monoxide. Do not run in an enclosed area. Read Owner's Manual before operation.</p>	supplied with product	attached to product
<p>⚠ ATTENTION</p> <p>L'essence est très inflammable et explosive. Arrêter le moteur et le laisser refroidir avant de faire le plein d'essence. Le moteur produit les vapeurs nocives de monoxyde de carbone. Ne pas utiliser dans un local clos. Lire le manuel de propriétaire avant l'utilisation.</p>	supplied with product	supplied with product

Honda factory equipped muffler.

MUFFLER CAUTION LABEL	
	not included
<p>⚠ CAUTION</p> <p>HOT MUFFLER CAN BURN YOU. Stay away if engine has been running.</p>	supplied with product
<p>⚠ ATTENTION</p> <p>L'ÉCHAPPEMENT CHAUD PEUT VOUS BRÛLER. S'ÉLOIGNER QUAND LE MOTEUR FONCTIONNE.</p>	supplied with product



Gasoline is highly flammable and explosive. Stop the engine and let cool before refueling.



The engine emits toxic poisonous carbon monoxide gas. Do not run in an enclosed area.



Read Owner's Manual before operation.



Hot muffler can burn you. Stay away if engine has been running.

COMPONENT & CONTROL LOCATION

OIL COOLER
(applicable types)

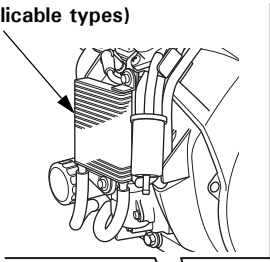

AIR CLEANER
(Dual-Filter Element)

PROTECTOR FAN
COVER

SPARK PLUG

OIL FILTER

FUEL FILTER

OIL DRAIN BOLT

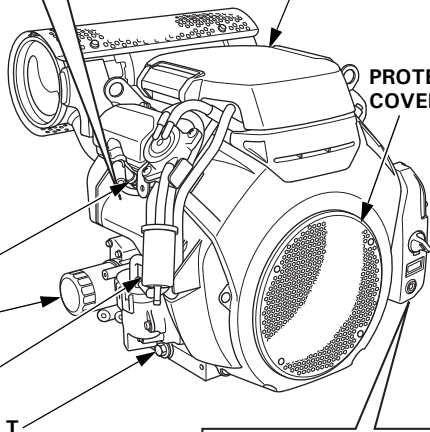

THROTTLE CONTROL
(applicable types)

ENGINE SWITCH
(applicable types)

HOUR METER
(applicable types)

INDICATOR
(applicable types)

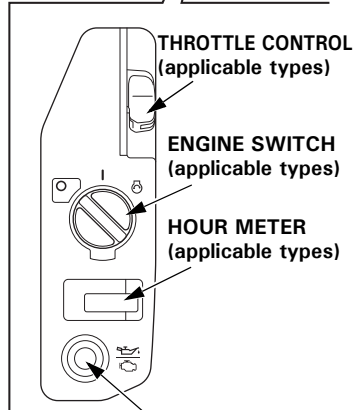

HIGH-MOUNT MUFFLER
(B type)

OIL FILLER CAP

OIL LEVEL
DIPSTICK

SPARK PLUG

ECU (engine
control unit)

OIL DRAIN BOLT

ELECTRIC STARTER

HIGH-MOUNT MUFFLER
(A type)

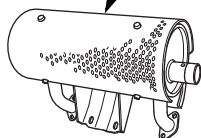

FEATURES

Oil Alert® System (applicable types)

“Oil Alert is a registered trademark in the United States”

The Oil Alert system is designed to prevent engine damage caused by an insufficient amount of oil in the crankcase. Before the oil level in the crankcase can fall below a safe limit, the indicator (red) comes on and the Oil Alert system will automatically stop the engine (the engine switch will remain in the ON position).

If the engine stops and will not restart, check the engine oil level (see page 8) before troubleshooting in other areas.

FI (fuel injection) System

The FI System system uses fuel injection. It has three subsystems: Air Intake, Engine Control, and Fuel Control. The ECU (engine control unit) uses various sensors to determine how much air is going into the engine. It then controls how much fuel to inject under all operating conditions.

If the indicator blinks (red) only once, the electrical system may have problem on its voltage, please check the voltage of the battery.

If there is no problem on the voltage or if the indicator blinks (red) twice or more, you may have a serious problem with the FI system. Take engine to your servicing dealer.

Hour Meter (applicable types)

After starting the engine, the elapsed time of the engine in use will be count.

It will not count the elapsed time of the engine operation by just turning the engine switch ON.

HOUR METER
(applicable
types)

INDICATOR
(RED)
(applicable
types)

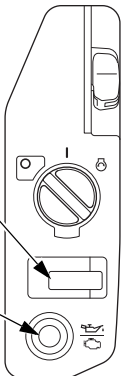

BEFORE OPERATION CHECKS

IS YOUR ENGINE READY TO GO?

For your safety, to ensure compliance with environmental regulations, and to maximize the service life of your equipment, it is very important to take a few moments before you operate the engine to check its condition. Be sure to take care of any problem you find, or have your servicing dealer correct it, before you operate the engine.

WARNING

Failure to properly maintain this engine, or failing to correct a problem before operation, could result in a significant malfunction.

Some malfunctions can cause serious injuries or death.

Always perform a pre-operation inspection before each operation and correct any problems.

Before beginning your pre-operation checks, be sure the engine is level and the engine switch is in the OFF position.

Always check the following items before you start the engine:

Check the General Condition of the Engine

1. Before each use, look around and underneath the engine for signs of oil or gasoline leaks.
2. Remove any excessive dirt or debris, especially around the muffler.
3. Look for signs of damage.
4. Check that all shields and covers are in place, and all nuts, bolts, and screws are tightened.

Check the Engine

1. Check the fuel level. Starting with a full tank will help to eliminate or reduce operating interruptions for refueling.
2. Check the engine oil level (see page 8). Running the engine with a low oil level can cause engine damage.

The Oil Alert system (applicable types) will automatically stop the engine before the oil level falls below safe limits. However, to avoid the inconvenience of an unexpected shutdown, always check the engine oil level before startup.

3. Check the air filter element (see page 9). A dirty air filter element will restrict air flow to the FI system, reducing engine performance.
4. Check the equipment powered by this engine.

Review the instructions provided with the equipment powered by this engine for any precautions and procedures that should be followed before engine startup.

OPERATION

SAFE OPERATING PRECAUTIONS

Before operating the engine for the first time, please review the *SAFETY INFORMATION* section on page 2 and the *BEFORE OPERATION CHECKS* on page 4.

Carbon Monoxide Hazards

For your safety, do not operate the engine in an enclosed area such as a garage. Your engine's exhaust contains poisonous carbon monoxide gas that can collect rapidly in an enclosed area and cause illness or death.

WARNING

Exhaust contains poisonous carbon monoxide gas that can build up to dangerous levels in closed areas.

Breathing carbon monoxide can cause unconsciousness or death.

Never run the engine in a closed, or even partly closed area.

Review the instructions provided with the equipment powered by this engine for any safety precautions that should be observed with engine startup, shutdown, or operation.

Do not operate the engine on slopes greater than 20° (36%).

STARTING THE ENGINE

1. If the fuel tank is equipped with a valve, be sure the fuel valve is in the OPEN or ON position before attempting to start the engine.
2. Move the throttle control to the MIN. position.

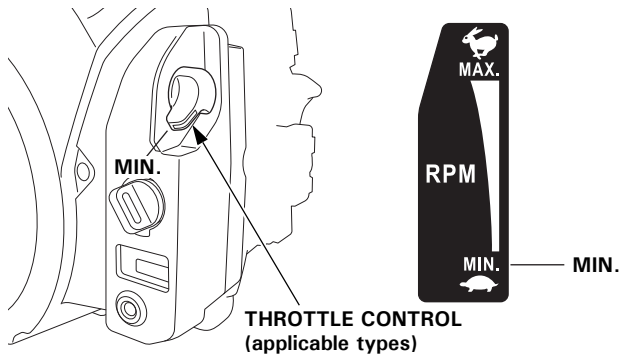

Some engine applications use a remote-mounted throttle control rather than the engine-mounted throttle control shown here. On the other hand, there are some applications that fix engine speed. Refer to the instructions provided by the equipment manufacturer.

3. Turn the engine switch to the ON position, indicator (red) comes on, and off (lamp check).

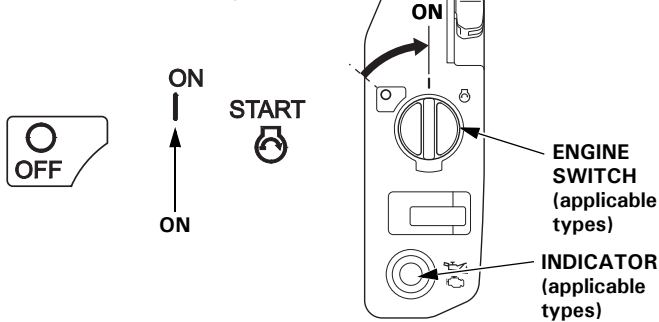

4. Operate the starter.

Turn the engine switch to the START position, and hold it there until the engine starts.

If the engine fails to start within 5 seconds, release the engine switch, and wait at least 10 seconds before operating the starter again.

NOTICE

Using the electric starter for more than 5 seconds at a time will overheat the starter motor and can damage it.

When the engine starts, release the engine switch, allowing it to return to the ON position.

Make sure the indicator is off (see page 3).

5. Warm up the engine for 2 or 3 minutes.

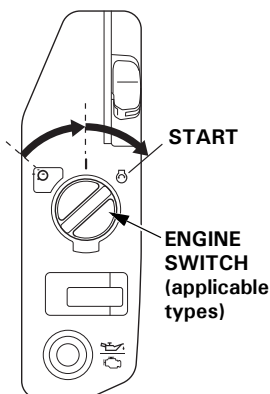

STOPPING THE ENGINE

To stop the engine in an emergency, simply turn the engine switch to the OFF position. Under normal conditions, use the following procedure. Refer to the instructions provided by the equipment manufacturer.

1. Move the throttle control to the MIN. position.

Some engine applications use a remote-mounted throttle control rather than the engine-mounted throttle control shown here. On the other hand, there are some applications that engine speed is fixed.

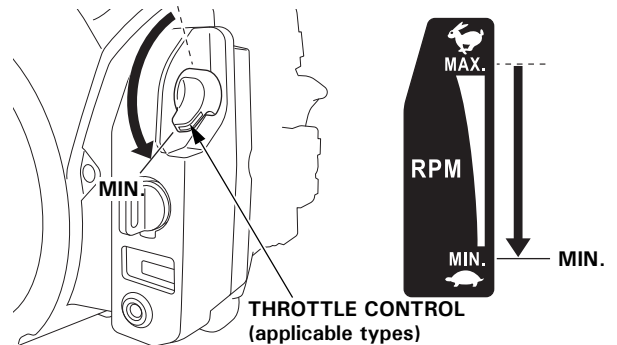

2. Turn the engine switch to the OFF position.

Although you may hear operating noise from the motor, it is not a malfunction.

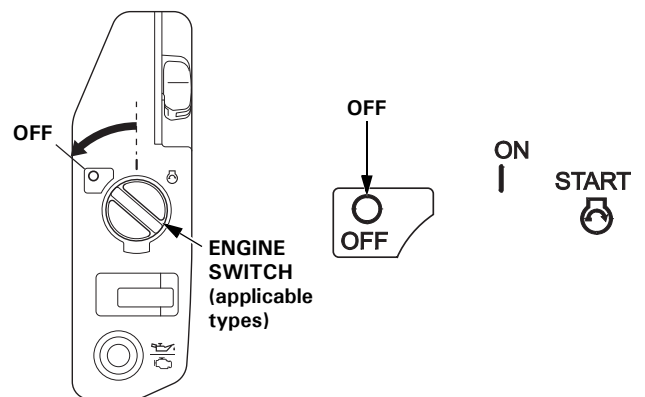

3. If the fuel tank is equipped with a valve, turn the fuel valve to the CLOSED or OFF position.

SETTING ENGINE SPEED

Position the throttle control for the desired engine speed.

Some engine applications use a remote-mounted throttle control rather than the engine-mounted throttle control shown here. On the other hand, there are some applications that are engine speed is fixed. Refer to the instructions provided by the equipment manufacturer.

For engine speed recommendations, refer to the instructions provided with the equipment powered by this engine.

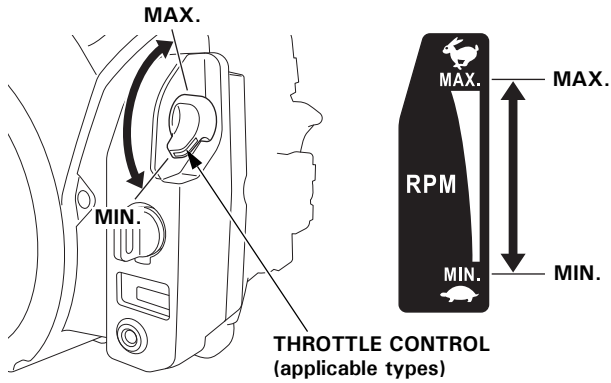

Do not disconnect the battery from the engine while the engine is running. If the battery is disconnected, the engine will stop.

SERVICING YOUR ENGINE

THE IMPORTANCE OF MAINTENANCE

Good maintenance is essential for safe, economical, and trouble-free operation. It will also help reduce pollution.

⚠ WARNING

Failure to properly maintain this engine, or failing to correct a problem before operation, could result in a significant malfunction.

Some malfunctions can cause serious injuries or death.

Always follow the inspection and maintenance recommendations and schedules in this owner's manual.

To help you properly care for your engine, the following pages include a maintenance schedule, routine inspection procedures, and simple maintenance procedures using basic hand tools. Other service tasks that are more difficult, or require special tools, are best handled by professionals and are normally performed by a Honda technician or other qualified mechanic.

The maintenance schedule applies to normal operating conditions. If you operate your engine under severe conditions, such as sustained high-load or high-temperature operation, or use in unusually wet or dusty conditions, consult your servicing dealer for recommendations applicable to your individual needs and use.

Maintenance, replacement, or repair of the emission control devices and systems may be performed by any engine repair establishment or individual, using parts that are "certified" to EPA standards.

MAINTENANCE SAFETY

Some of the most important safety precautions follow. However, we cannot warn you of every conceivable hazard that can arise in performing maintenance. Only you can decide whether or not you should perform a given task.

⚠ WARNING

Improper maintenance can cause an unsafe condition.

Failure to properly follow maintenance instructions and precautions can cause serious injuries or death.

Always follow the procedures and precautions in this owner's manual.

SAFETY PRECAUTIONS

- Make sure the engine is off before you begin any maintenance or repairs. To prevent accidental startup, disconnect the spark plug cap. This will eliminate several potential hazards:
 - **Carbon monoxide poisoning from engine exhaust.**
Operate outside, away from open windows or doors.
 - **Burns from hot parts.**
Let the engine and exhaust system cool before touching.
 - **Injury from moving parts.**
Do not run the engine unless instructed to do so.
- Read the instructions before you begin, and make sure you have the tools and skills required.
- To reduce the possibility of fire or explosion, be careful when working around gasoline. Use only a non-flammable solvent, not gasoline, to clean parts. Keep cigarettes, sparks and flames away from all fuel related parts.

Remember that an authorized Honda servicing dealer knows your engine best and is fully equipped to maintain and repair it.

To ensure the best quality and reliability, use only new Honda Genuine parts or their equivalents for repair and replacement.

MAINTENANCE SCHEDULE

REGULAR SERVICE PERIOD (1) Perform at every indicated month or operating hour interval, whichever comes first.		Each Use	First Month or 20 Hrs	Every 6 Months or 100 Hrs	Every Year or 300 Hrs	Every 2 Years or 500 Hrs	Refer to Page
ITEM							
Engine oil	Check level	o					8
	Change		o	o			8
Engine oil filter	Replace	Every 200 Hrs. (4)					—
Air cleaner	Check	o					9
	Clean			o (2)			9
	Replace					o *	
Oil cooler (applicable types)	Check	o (3)					—
Spark plug	Check-adjust			o			10
	Replace				o		
Spark arrester (applicable types)	Clean			o (5)			10
Valve clearance	Check-adjust				o (4)		—
Combustion chamber	Clean	After every 1000 Hrs. (4)					—
Fuel filter	Replace				o (4)		—
Fuel tube	Check	Every 2 years (Replace if necessary) (4)					—

* Replace the paper filter element only.

- (1) For commercial use, log hours of operation to determine proper maintenance intervals.
- (2) Service more frequently when used in dusty areas.
- (3) If there are deposits of grass, trash, or other debris, clean regularly.
- (4) These items should be serviced by your servicing dealer, unless you have the proper tools and are mechanically proficient. Refer to the Honda shop manual for service procedures.
- (5) In Europe and other countries where the machinery directive 2006/42/EC is enforced, this service should be done by your servicing dealer.

Failure to follow this maintenance schedule could result in non-warrantable failures.

REFUELING

Recommended Fuel

Unleaded gasoline		
U.S.		Pump octane rating 86 or higher
Except U.S.		Research octane rating 91 or higher
		Pump octane rating 86 or higher

This engine is certified to operate on unleaded gasoline with a pump octane rating of 86 or higher (a research octane rating of 91 or higher).

Refuel in a well ventilated area with the engine stopped. If the engine has been running, allow it to cool first. Never refuel the engine inside a building where gasoline fumes may reach flames or sparks.

You may use unleaded gasoline containing no more than 10% ethanol (E10) or 5% methanol by volume. In addition, methanol must contain cosolvents and corrosion inhibitors. Use of fuels with content of ethanol or methanol greater than shown above may cause starting and/or performance problems. It may also damage metal, rubber, and plastic parts of the fuel system.

Engine damage or performance problems that result from using a fuel with percentages of ethanol or methanol greater than shown above are not covered under the Warranty.

If your equipment will be used on an infrequent or intermittent basis, please refer to the fuel section of the **STORING YOUR ENGINE** chapter (see page 11) for additional information regarding fuel deterioration.

WARNING

Gasoline is highly flammable and explosive.

You can be burned or seriously injured when handling fuel.

- Stop the engine and let it cool before handling fuel.
- Keep heat, sparks, and flame away.
- Handle fuel only outdoors.
- Keep away from your vehicle.
- Wipe up spills immediately.

NOTICE

Fuel can damage paint and some types of plastic. Be careful not to spill fuel when filling your fuel tank. Damage caused by spilled fuel is not covered under the Distributor's Limited Warranty.

Never use gasoline that is stale, contaminated, or mixed with oil. Avoid getting dirt or water in the fuel tank.

With the engine stopped and on a level surface, remove the fuel filler cap and check the fuel level. Refill the tank if the fuel level is low. Refer to the instructions provided with the equipment powered by this engine for refueling.

Refuel in a well-ventilated area before starting the engine. If the engine has been running, allow it to cool. Refuel carefully to avoid spilling fuel. It may be necessary to lower the fuel level depending on operating conditions. After refueling, tighten the fuel tank cap securely.

Keep gasoline away from appliance pilot lights, barbecues, electric appliances, power tools, etc.

Spilled fuel is not only a fire hazard, it causes environmental damage. Wipe up spills immediately.

ENGINE OIL

Oil is a major factor affecting performance and service life. Use 4-stroke automotive detergent oil.

Recommended Oil

Use 4-stroke motor oil that meets or exceeds the requirements for API service category SJ or later (or equivalent). Always check the API service label on the oil container to be sure it includes the letters SJ or later (or equivalent).

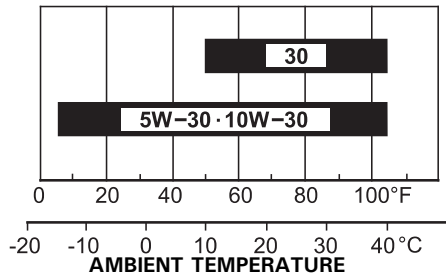

SAE 10W-30 is recommended for general use. Other viscosities shown in the chart may be used when the average temperature in your area is within the indicated range.

Oil Level Check

Check the engine oil level with the engine stopped and in a level position.

1. Start the engine and let it idle for 1 to 2 minutes. Stop the engine and wait for 2 to 3 minutes.
2. Remove the oil level dipstick by pulling it. Wipe the oil level dipstick clean.
3. Fully insert the oil level dipstick, then remove it to check the oil level.
4. If the oil level is near or below the lower limit mark on the dipstick, remove the oil filler cap, and fill with the recommended oil to the upper limit mark. Do not overfill. Refer to "Recommended Oil".
5. Fully insert the oil level dipstick. Reinstall the oil filler cap securely.

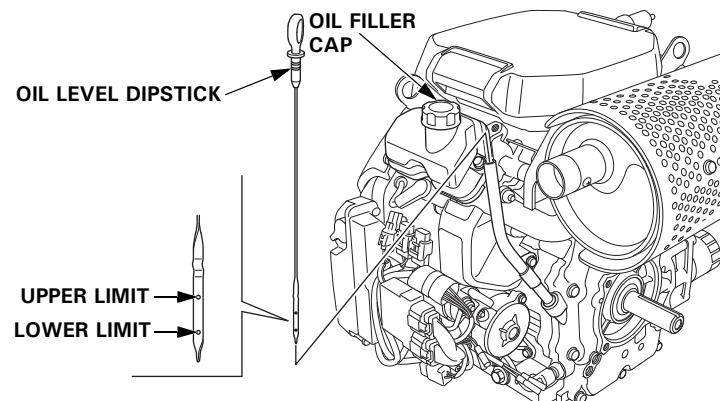

NOTICE

Running the engine with a low oil level can cause engine damage. This type of damage is not covered by the Distributor's Limited Warranty.

The Oil Alert system (applicable types) will automatically stop the engine before the oil level falls below the safe limit. However, to avoid the inconvenience of an unexpected shutdown, always check the engine oil level before startup.

Oil Change

Drain the used oil when the engine is warm. Warm oil drains quickly and completely.

1. Place a suitable container below the engine to catch the used oil, and then remove the oil filler cap, drain bolt, and sealing washer.
2. Allow the used oil to drain completely, then reinstall the drain bolt and new sealing washer, and tighten the drain bolt securely.

TORQUE: 45.0 N·m (4.5 kgf·m, 33 lbf·ft)

Please dispose of used motor oil in a manner that is compatible with the environment. We suggest you take used oil in a sealed container to your local recycling center or service station for reclamation. Do not throw it in the trash, pour it on the ground, or pour it down a drain.

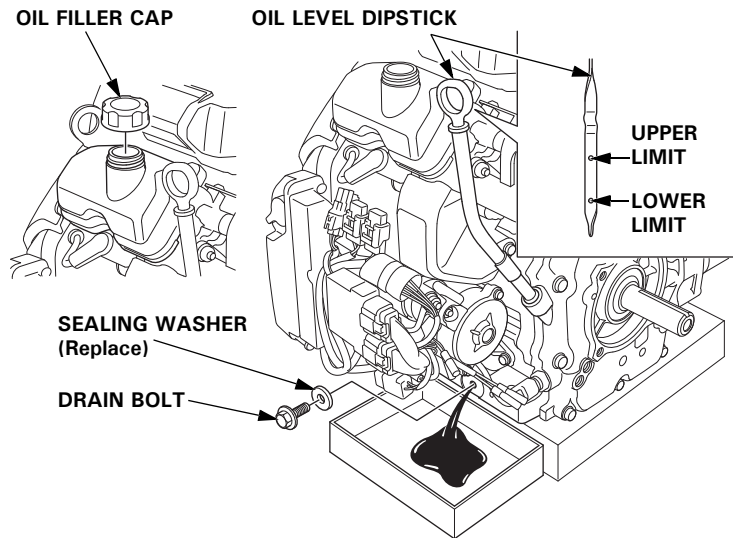

3. With the engine in a level position, fill with the recommended oil to the upper limit mark on the oil level dipstick.

Engine oil capacity:

Without oil filter replacement:

iGX700: 1.5 L (1.6 US qt, 1.3 Imp qt)

iGX800: 1.6 L (1.7 US qt, 1.4 Imp qt)

With oil filter replacement:

iGX700: 1.7 L (1.8 US qt, 1.5 Imp qt)

iGX800: 1.8 L (1.9 US qt, 1.6 Imp qt)

NOTICE

Running the engine with a low oil level can cause engine damage. This type of damage is not covered by the Distributor's Limited Warranty.

The Oil Alert system (applicable types) will automatically stop the engine before the oil level falls below the safe limit. However, to avoid the inconvenience of an unexpected shutdown, fill to the upper limit, and check the oil level regularly.

4. Reinstall the oil filler cap and oil level dipstick securely.

AIR CLEANER

A dirty air cleaner will restrict air flow to the FI system, reducing engine performance. If you operate the engine in very dusty areas, clean the air filter more often than specified in the MAINTENANCE SCHEDULE (see page 7).

NOTICE

Operating the engine without an air filter, or with a damaged air filter, will allow dirt to enter the engine, causing rapid engine wear. This type of damage is not covered by the Distributor's Limited Warranty.

Inspection

Remove the air cleaner cover and inspect the filter elements. Clean or replace dirty filter elements. Always replace damaged filter elements.

Cleaning

1. Pull the air cleaner cover latch to the unlocked position, and remove the cover.
2. Remove the wing nut from the paper filter element.
3. Remove the paper filter element and foam filter element from the air cleaner case.
4. Remove the foam filter element from the paper filter element.

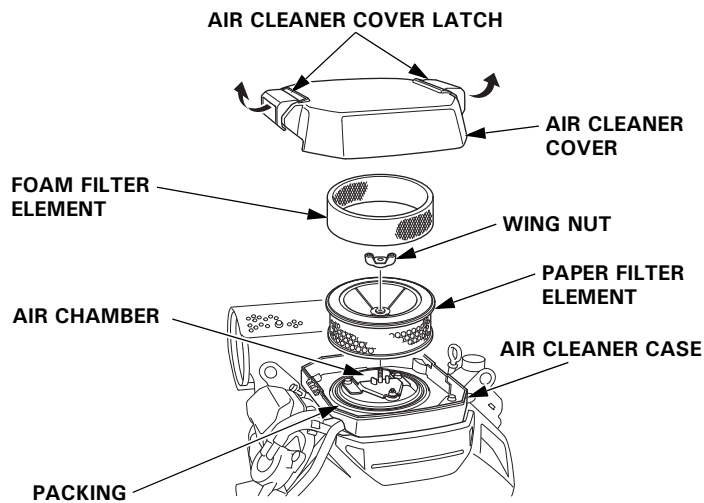

5. Inspect both filter elements, and replace them if they are damaged. Always replace the paper filter element at the scheduled interval (see page 7).

6. Clean the filter elements if they are to be reused.

Paper filter element: Tap the filter element several times on a hard surface to remove dirt, or blow compressed air [not exceeding 207 kPa (2.1 kgf/cm², 30 psi)] through the filter element from the air cleaner case side.

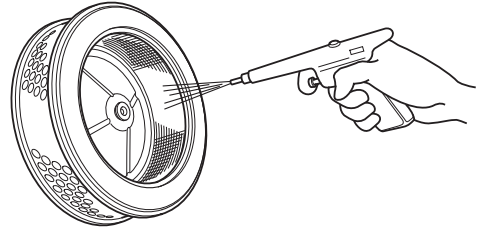

Never try to brush off dirt; brushing will force dirt into the fibers. Replace the paper filter element if it is excessively dirty.

Foam filter element: Clean in warm soapy water, rinse, and allow to dry thoroughly. Or clean in non-flammable solvent and allow to dry. Dip the filter element in clean engine oil, and then squeeze out all excess oil. The engine will smoke when started if too much oil is left in the foam.

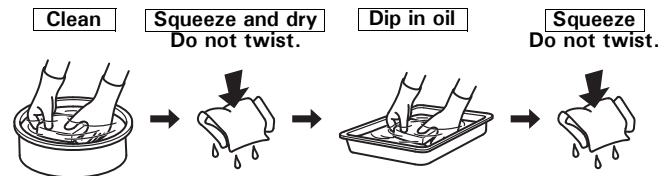

7. Wipe dirt from the inside of the air cleaner body and cover, using a moist rag. Be careful to prevent dirt from entering the air chamber that leads to the FI system.
8. Place the foam filter element over the paper filter element, and reinstall the assembled filter element. Be sure the packing is in place beneath the filter element. Tighten the wing nut securely.
9. Lock the air cleaner cover latch securely.

SPARK PLUG

Recommended Spark Plug: BPR5ES (NGK)

The recommended spark plug has the correct heat range for normal engine operating temperatures.

NOTICE

Incorrect spark plugs can cause engine damage.

If the engine has been running, let it cool before servicing the spark plugs.

For good performance, the spark plugs must be properly gapped and free of deposits.

1. Disconnect the spark plug caps, and remove any dirt from around the spark plug area.
2. Remove the spark plugs with a 13/16-inch spark plug wrench.

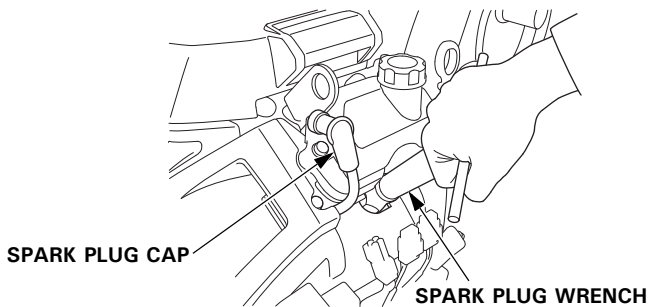

3. Inspect the spark plugs. Replace them if damaged, badly fouled, if the sealing washer is in poor condition, or if the electrode is worn.

4. Measure the spark plug electrode gaps with a wire-type feeler gauge. Correct the gap, if necessary, by carefully bending the side electrode. The gap should be:
0.7–0.8 mm
(0.028–0.031 in)

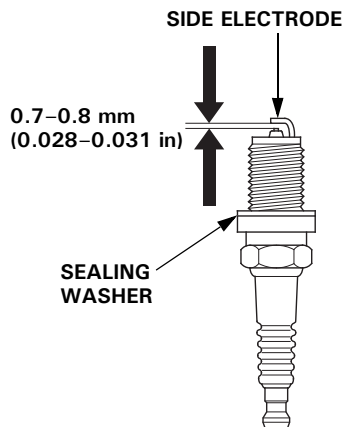

5. Install the spark plug carefully, by hand, to avoid cross-threading.
6. After the spark plug is seated, tighten with a 13/16-inch spark plug wrench to compress the sealing washer.

When installing a new spark plug, tighten 1/2 turn after the spark plug seats to compress the washer.

When reinstalling a used spark plug, tighten 1/8–1/4 turn after the spark plug seats to compress the washer.

TORQUE: 18.0 N·m (1.8 kgf·m, 13 lbf·ft)

NOTICE

A loose spark plug can overheat and damage the engine. Overtightening the spark plug can damage the threads in the cylinder head.

7. Attach the spark plug caps to the spark plugs.

SPARK ARRESTER (applicable types)

In Europe and other countries where the machinery directive 2006/42/EC is enforced, this cleaning should be done by your servicing dealer.

Your engine is not factory-equipped with a spark arrester. The spark arrester is optional part. In some areas, it is illegal to operate an engine without a spark arrester. Check local laws and regulations. A spark arrester is available from authorized Honda servicing dealers.

The spark arrester must be serviced every 100 hours to keep it functioning as designed.

If the engine has been running, the muffler will be hot. Allow it to cool before servicing the spark arrester.

Spark Arrester Cleaning & Inspection

1. Remove the spark arrester:

Remove the special screw from the muffler and remove the spark arrester.

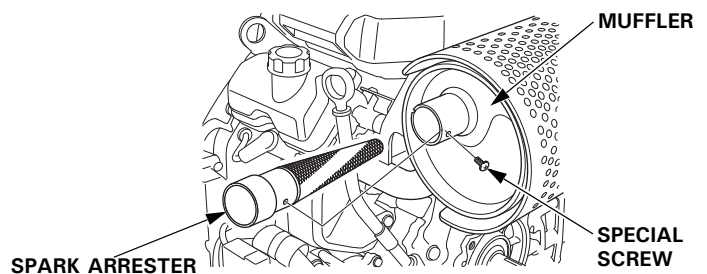

2. Use a brush to remove carbon deposits from the spark arrester screen. Be careful to avoid damaging the screen.

The spark arrester must be free of breaks and holes. Replace the spark arrester if it is damaged.

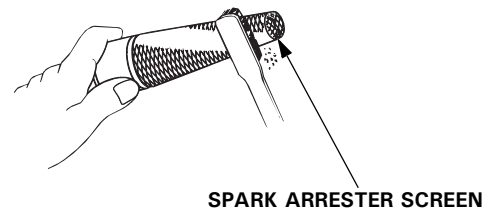

3. Install the spark arrester and muffler protector in the reverse order of disassembly.

HELPFUL TIPS & SUGGESTIONS

STORING YOUR ENGINE

Storage Preparation

Proper storage preparation is essential for keeping your engine trouble-free and looking good. The following steps will help to keep rust and corrosion from impairing your engine's function and appearance, and will make the engine easier to start when you use it again.

Cleaning

If the engine has been running, allow it to cool for at least half an hour before cleaning. Clean all exterior surfaces, touch up any damaged paint, and coat other areas that may rust with a light film of oil.

NOTICE

Using a garden hose or pressure washing equipment can force water into the air cleaner or muffler opening. Water in the air cleaner will soak the air filter, and water that passes through the air filter or muffler can enter the cylinder, causing damage.

Fuel

NOTICE

Depending on the region where you operate your equipment, fuel formulations may deteriorate and oxidize rapidly. Fuel deterioration and oxidation can occur in as little as 30 days and may cause damage to the FI system. Please check with your servicing dealer for local storage recommendations.

Gasoline will oxidize and deteriorate in storage. Deteriorated gasoline will cause hard starting, and it leaves gum deposits that clog the FI system. If the gasoline in your engine deteriorates during storage, you may need to have the FI system components serviced or replaced.

The length of time that gasoline can be left in your fuel tank without causing functional problems will vary with such factors as gasoline blend, your storage temperatures, and whether the fuel tank is partially or completely filled. The air in a partially filled fuel tank promotes fuel deterioration. Very warm storage temperatures accelerate fuel deterioration. Fuel deterioration problems may occur within a few months, or even less if the gasoline was not fresh when you filled the fuel tank.

FI system damage or engine performance problems resulting from neglected storage preparation are not covered under the *Distributor's Limited Warranty*.

You can extend fuel storage life by adding a gasoline stabilizer that is formulated for that purpose, or you can avoid fuel deterioration problems by draining the fuel tank.

Adding a Gasoline Stabilizer to Extend Fuel Storage Life

When adding a gasoline stabilizer, fill the fuel tank with fresh gasoline. If only partially filled, air in the tank will promote fuel deterioration during storage. If you keep a container of gasoline for refueling, be sure that it contains only fresh gasoline.

1. Add gasoline stabilizer following the manufacturer's instructions.
2. After adding a gasoline stabilizer, run the engine outdoors.
3. Stop the engine, and if the fuel tank is equipped with a fuel valve, move the fuel valve to the CLOSED or OFF position.

Draining the Fuel Tank

⚠ WARNING

Gasoline is highly flammable and explosive.

You can be burned or seriously injured when handling fuel.

- Stop the engine and let it cool before handling fuel.
- Keep heat, sparks, and flame away.
- Handle fuel only outdoors.
- Keep away from your vehicle.
- Wipe up spills immediately.

1. Disconnect the fuel line to the engine, and drain the fuel tank into an approved gasoline container. If the fuel tank is equipped with a valve, turn the fuel valve to the OPEN or ON position to enable draining. After draining is completed, reconnect the fuel line.
2. To drain the FI system completely, start the engine (see page 5) and allow the engine to run until it stops.
3. When the engine stops, turn the engine switch to the OFF position.

Leaving the engine switch at the ON position will drain the battery.
4. If the fuel tank is equipped with a valve, turn the fuel valve to the CLOSED or OFF position.

Engine Oil

1. Change the engine oil (see page 8).
2. Remove the spark plugs (see page 10).
3. Pour 5–10 cm³ (5–10 cc, 1–2 teaspoons) of clean engine oil into each cylinder.
4. Turn the engine for a few seconds by turning the engine switch to the START position to distribute the oil in the cylinders.
5. Reinstall the spark plugs.

Storage Precautions

If your engine will be stored with gasoline in the fuel tank, it is important to reduce the hazard of gasoline vapor ignition. Select a well ventilated storage area away from any appliance that operates with a flame, such as a furnace, water heater, or clothes dryer. Also avoid any area with a spark-producing electric motor, or where power tools are operated.

If possible, avoid storage areas with high humidity, because that promotes rust and corrosion.

Keep the engine level in storage. Tilting can cause fuel or oil leakage.

Unless all fuel has been drained from the fuel tank, leave the fuel valve in the CLOSED or OFF position to reduce the possibility of fuel leakage.

With the engine and exhaust system cool, cover the engine to keep out dust. A hot engine and exhaust system can ignite or melt some materials. Do not use a plastic sheet as a dust cover. A nonporous cover will trap moisture around the engine, promoting rust and corrosion.

If installed, remove the battery and store it in a cool, dry place. Recharge the battery once a month while the engine is in storage. This will help to extend the service life of the battery.

Removal from Storage

Check your engine as described in the *BEFORE OPERATION CHECKS* section of this manual (see page 4).

If the fuel was drained during storage preparation, fill the tank with fresh gasoline. If you keep a container of gasoline for refueling, be sure it contains only fresh gasoline. Gasoline oxidizes and deteriorates over time, causing hard starting.

If the cylinders were coated with oil during storage preparation, the engine may smoke briefly at startup. This is normal.

TRANSPORTING

If the engine has been running, allow it to cool for at least 15 minutes before loading the engine-powered equipment on the transport vehicle. A hot engine and exhaust system can burn you and can ignite some materials.

Keep the engine level when transporting to reduce the possibility of fuel leakage. If the fuel tank is equipped with a fuel valve, move the fuel valve lever to the CLOSED or OFF position.

TAKING CARE OF UNEXPECTED PROBLEMS

ENGINE WILL NOT START

Possible Cause	Correction
Battery discharged.	Recharge battery.
Fuse burnt out.	Replace fuse.
Fuel valve CLOSED or OFF. (If equipped)	Move lever to OPEN or ON position.
Engine switch OFF.	Turn engine switch to ON position (p. 5).
Engine oil level low (Oil Alert stops engine).	Fill with the recommended oil to the proper level (p. 8).
Out of fuel.	Refuel (p. 7).
Stale fuel; engine stored without treating or draining gasoline, or refueled with stale gasoline.	Drain fuel tank (p. 11). Refuel with fresh gasoline (p. 7).
Spark plugs faulty, fouled, or improperly gapped.	Gap, or replace spark plugs (p. 10).
Spark plugs wet with fuel (flooded engine).	Dry and reinstall spark plugs (p. 10).
Fuel filter restricted, FI system malfunction, ignition malfunction, valves stuck, etc.	Take engine to your servicing dealer, or refer to shop manual.

ENGINE LACKS POWER

Possible Cause	Correction
Filter element(s) restricted.	Clean or replace filter element(s) (p. 9).
Stale fuel; engine stored without treating or draining gasoline, or refueled with stale gasoline.	Drain fuel tank (p. 11). Refuel with fresh gasoline (p. 7).
Fuel filter restricted, FI system malfunction, ignition malfunction, valves stuck, etc.	Take engine to your servicing dealer, or refer to shop manual.

FUSE REPLACEMENT

The electric system circuit system is protected by a fuse. If the fuse burns out, the electric system will not operate.

1. Remove the fuse cover, and inspect the fuse.

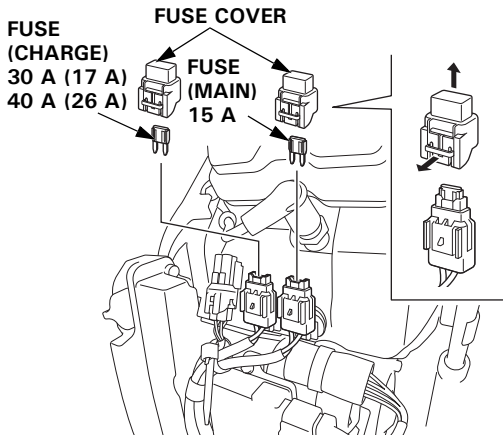

If the fuse is burnt out, pull out and discard the burnt-out fuse. Install a new fuse.

NOTICE

Never use a fuse with a different rating from that specified. Serious damage to the electrical system or a fire could result.

2. Reinstall the fuse cover.

Fuse failure usually indicates a short circuit or an overload in the electrical system. If the fuse burns out, take the engine to your servicing dealer for repair.

TECHNICAL INFORMATION

Serial Number Location

Record the engine serial number, type and purchase date in the spaces below. You will need this information when ordering parts and when making technical or warranty inquiries.

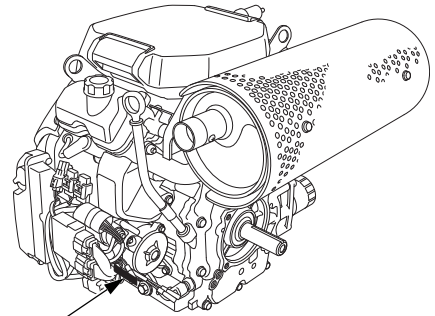

**SERIAL NUMBER &
ENGINE TYPE LOCATION**

Engine serial number: _____

Engine type: _____

Date Purchased: ____ / ____ / ____

Battery Connections for Electric Starter

Recommended Battery: 55B24 (12 V-36 Ah)

Be careful not to connect the battery in reverse polarity, as this will short circuit the electrical system. Always connect the positive (+) battery cable to the battery terminal before connecting the negative (-) battery cable, so your tools cannot cause a short circuit if they touch a grounded part while tightening the positive (+) battery cable end.

Make sure to keep the battery cable away from the ECU (engine control unit).

⚠ WARNING

A battery can explode if you do not follow the correct procedure, seriously injuring anyone nearby.

Keep all sparks, open flames, and smoking materials away from the battery.

WARNING: Battery posts, terminals, and related accessories contain lead and lead compounds. **Wash your hands after handling.**

Make sure the engine switch to the OFF position (see page 5).

1. Connect the battery positive (+) cable to the starter solenoid terminal as shown.
2. Connect the battery negative (-) cable to an engine mounting bolt, frame bolt, or other good engine ground connection.
3. Connect the battery positive (+) cable to the battery positive (+) terminal as shown.
4. Connect the battery negative (-) cable to the battery negative (-) terminal as shown.
5. Coat the terminals and cable ends with grease.

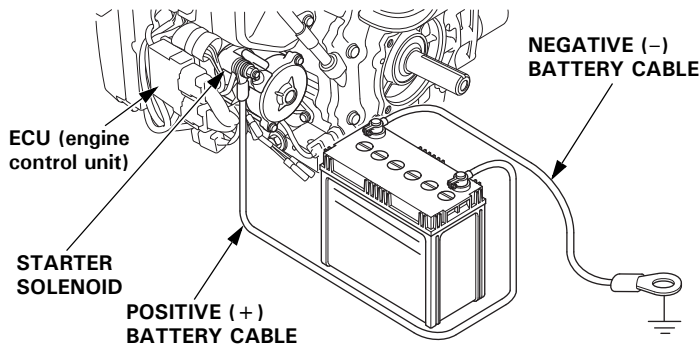

⚠ WARNING

The battery contains sulfuric acid (electrolyte), which is highly corrosive and poisonous.

Getting electrolyte in your eyes or on your skin can cause serious burns.

Wear protective clothing and eye protection when working near the battery.

KEEP CHILDREN AWAY FROM THE BATTERY.

Emission Control System Information

Emission Control System Warranty

Your new Honda complies with both the U.S. EPA and State of California emission regulations. American Honda provides the same emission warranty coverage for Honda Power Equipment engines sold in all 50 states. In all areas of the United States, your Honda Power Equipment engine is designed, built, and equipped to meet the U.S. EPA and California Air Resources Board emission standard for spark ignited engines.

Warranty Coverage

Honda Power Equipment engines certified to CARB and U.S. EPA regulations are covered by this warranty to be free from defects in materials and workmanship that may keep it from meeting the applicable U.S. EPA and CARB emissions requirements for a minimum of 2 years or the length of the *Honda Power Equipment Distributor's Limited Warranty*, whichever is longer, from the original date of delivery to the retail purchaser. This warranty is transferable to each subsequent purchaser for the duration of the warranty period.

Warranty repairs will be made without charge for diagnosis, parts, and labor. Information about how to make a warranty claim, as well as a description of how a claim can be made and/or how service can be provided, can be obtained by contacting an authorized Honda Power Equipment dealer or by contacting American Honda at the following:

Email: powerequipmentemissions@ahm.honda.com

Telephone: (888) 888-3139

The covered components include all components whose failure would increase an engine's emissions of any regulated pollutant or evaporative emissions. A list of specific components can be found in the separately included emissions warranty statement.

Specific warranty terms, coverage, limitations and manner of seeking warranty service are also set forth in the separately included emissions warranty statement. In addition, the emissions warranty statement can also be found on the Honda Power equipment website or at the following link:

<http://powerequipment.honda.com/support/warranty>

Source of Emissions

The combustion process produces carbon monoxide, oxides of nitrogen, and hydrocarbons. Control of hydrocarbons and oxides of nitrogen are very important because, under certain conditions, they react to form photochemical smog when subjected to sunlight.

Carbon monoxide does not react in the same way, but it is toxic.

Honda utilizes appropriate air/fuel ratios and other emissions control systems to reduce the emissions of carbon monoxide, oxides of nitrogen, and hydrocarbons.

Additionally, Honda fuel systems utilize components and control technologies to reduce evaporative emissions.

The U.S. and California Clean Air Acts, and Environment and Climate Change Canada (ECCC)

U.S. EPA, California and Canadian regulations require all manufacturers to furnish written instructions describing the operation and maintenance of emission control systems.

The following instructions and procedures must be followed in order to keep the Honda engine emissions within the emission standards.

Tampering and Altering

NOTICE

Tampering is a violation of federal and California law.

Tampering with or altering the emission control system may increase emissions beyond the legal limit. Among those acts that constitute tampering are:

- Removal or alteration of any part of the intake, fuel, or exhaust systems.
- Altering or defeating the governor linkage or speed-adjusting mechanism to cause the engine to operate outside its design parameters.

Problems That May Affect Emissions

If you are aware of any of the following symptoms, have your engine inspected and repaired by your servicing dealer.

- Hard starting or stalling after starting.
- Rough idle.
- Misfiring or backfiring under load.
- Afterburning (backfiring).
- Black exhaust smoke or high fuel consumption.

Replacement Parts

The emissions control systems on your new Honda engine were designed, built, and certified to conform with U.S. EPA, California, and Canadian emissions regulations. We recommend the use of Honda Genuine parts whenever you have maintenance done. These original-design replacement parts are manufactured to the same standards as the original parts, so you can be confident of their performance. Honda cannot deny coverage under the emission warranty solely for the use of non-Honda replacement parts or service performed at a location other than an authorized Honda dealership; you may use comparable U.S. EPA certified parts, and have service performed at non-Honda locations. However, the use of replacement parts that are not of the original design and quality may impair the effectiveness of your emissions control system.

A manufacturer of an aftermarket part assumes the responsibility that the part will not adversely affect emissions performance. The manufacturer or rebuilder of the part must certify that use of the part will not result in a failure of the engine to comply with emissions regulations.

Maintenance

As the power equipment engine owner, you are responsible for completing all required maintenance listed in your owner's manual. Honda recommends that you retain all receipts covering maintenance on your power equipment engine, but Honda cannot deny warranty coverage solely for the lack of receipts or for your failure to ensure that all scheduled maintenance has been completed.

Follow the MAINTENANCE SCHEDULE on page 7.

Remember that this schedule is based on the assumption that your engine will be used for its designed purpose. Sustained high-load or high-temperature operation, or use in dusty conditions, will require more frequent service.

Air Index

(Models certified for sale in California)

An Air Index Information label is applied to engines certified to an emission durability time period in accordance with the requirements of the California Air Resources Board.

The bar graph is intended to provide you, our customer, the ability to compare the emissions performance of available engines. The lower the Air Index, the less pollution.

The durability description is intended to provide you with information relating to the engine's emission durability period. The descriptive term indicates the useful life period for the engine's emission control system. See your *Emission Control System Warranty* for additional information.

Descriptive Term	Applicable to Emissions Durability Period
Moderate	50 hours (0–80 cc, inclusive) 125 hours (greater than 80 cc)
Intermediate	125 hours (0–80 cc, inclusive) 250 hours (greater than 80 cc)
Extended	300 hours (0–80 cc, inclusive) 500 hours (greater than 80 cc) 1,000 hours (225 cc and greater)

The Air Index Information hang tag/label must remain on the engine until it is sold. Remove the hang tag before operating the engine.

Specifications

iGX700 (TXA2 Type)

Length × Width × Height	429 × 483 × 438 mm (16.9 × 19.0 × 17.2 in)
Dry mass [weight]	47.1 kg (103.8 lbs)
Engine type	4-stroke, overhead valve, 2 cylinders (90° V-Twin)
Displacement [Bore × Stroke]	688.0 cm ³ (41.97 cu-in) [78.0 × 72.0 mm (3.07 × 2.83 in)]
Net power <small>(in accordance with SAE J1349*)</small>	16.5 kW (22.4 PS, 22.1 bhp) at 3,600 min ⁻¹ (rpm)
Max. Net torque <small>(in accordance with SAE J1349*)</small>	48.3 N·m (4.93 kgf·m, 35.6 lbf·ft) at 2,500 min ⁻¹ (rpm)
Engine oil capacity	Without oil filter replacement: 1.5 L (1.6 US qt, 1.3 Imp qt) With oil filter replacement: 1.7 L (1.8 US qt, 1.5 Imp qt)
Cooling system	Forced air
Ignition system	Full transistorized ignition
PTO shaft rotation	Counterclockwise (from PTO end)

iGX800 (TXA2 Type)

Length × Width × Height	429 × 492 × 438 mm (16.9 × 19.4 × 17.2 in)
Dry mass [weight]	46.9 kg (103.4 lbs)
Engine type	4-stroke, overhead valve, 2 cylinders (90° V-Twin)
Displacement [Bore × Stroke]	779.0 cm ³ (47.52 cu-in) [83.0 × 72.0 mm (3.27 × 2.83 in)]
Net power <small>(in accordance with SAE J1349*)</small>	18.6 kW (25.3 PS, 24.9 bhp) at 3,600 min ⁻¹ (rpm)
Max. Net torque <small>(in accordance with SAE J1349*)</small>	54.5 N·m (5.56 kgf·m, 40.2 lbf·ft) at 2,500 min ⁻¹ (rpm)
Engine oil capacity	Without oil filter replacement: 1.6 L (1.7 US qt, 1.4 Imp qt) With oil filter replacement: 1.8 L (1.9 US qt, 1.6 Imp qt)
Cooling system	Forced air
Ignition system	Full transistorized ignition
PTO shaft rotation	Counterclockwise (from PTO end)

* The power rating of the engine indicated in this document is the net power output tested on a production engine for the engine model and measured in accordance with SAE J1349 at 3,600 min⁻¹(rpm) (Net Power) and at 2,500 min⁻¹(rpm) (Max. Net Torque).

Mass production engines may vary from this value.

Actual power output for the engine installed in the final machine will vary depending on numerous factors, including the operating speed of the engine in application, environmental conditions, maintenance, and other variables.

Tuneup Specifications

ITEM	SPECIFICATION	MAINTENANCE
Spark plug gap	0.7–0.8 mm (0.028–0.031 in)	Refer to page 10
Valve clearance (cold)	IN: 0.20 ± 0.02 mm EX: 0.20 ± 0.02 mm	See your servicing dealer
Other specifications	No other adjustments needed.	

Quick Reference Information

Fuel	Unleaded gasoline (Refer to page 7).	
	U.S.	Pump octane rating 86 or higher
	Except U.S.	Research octane rating 91 or higher Pump octane rating 86 or higher
Engine oil	SAE 10W-30, API SJ or later, for general use. Refer to page 8.	
Spark plug	BPR5ES (NGK)	
Maintenance	Before each use:	
	<ul style="list-style-type: none"> • Check engine oil level. Refer to page 8. • Check air filter. Refer to page 9. 	
	First 20 hours: Change engine oil. Refer to page 8.	
	Subsequent: Refer to the maintenance schedule on page 7.	

Wiring Diagrams

- (A) FUSE
- (B) ENGINE SWITCH
- (C) OIL LEVEL SWITCH
- (D) STARTER MOTOR
- (E) BATTERY
- (F) CHARGE COIL
- (G) IGNITION COIL
- (H) SPARK PLUG
- (I) REGULATOR RECTIFIER
- (J) HOUR METER
- (K) CONTROL BOX
- (L) FUEL PUMP
- (M) THROTTLE CONTROL
- (N) INJECTION
- (O) PULSER COIL

- Bl Black
- Br Brown
- Bu Blue
- G Green
- Gr Gray
- Lb Light blue
- Lg Light green
- O Orange
- P Pink
- R Red
- W White
- Y Yellow

With Control Box Type

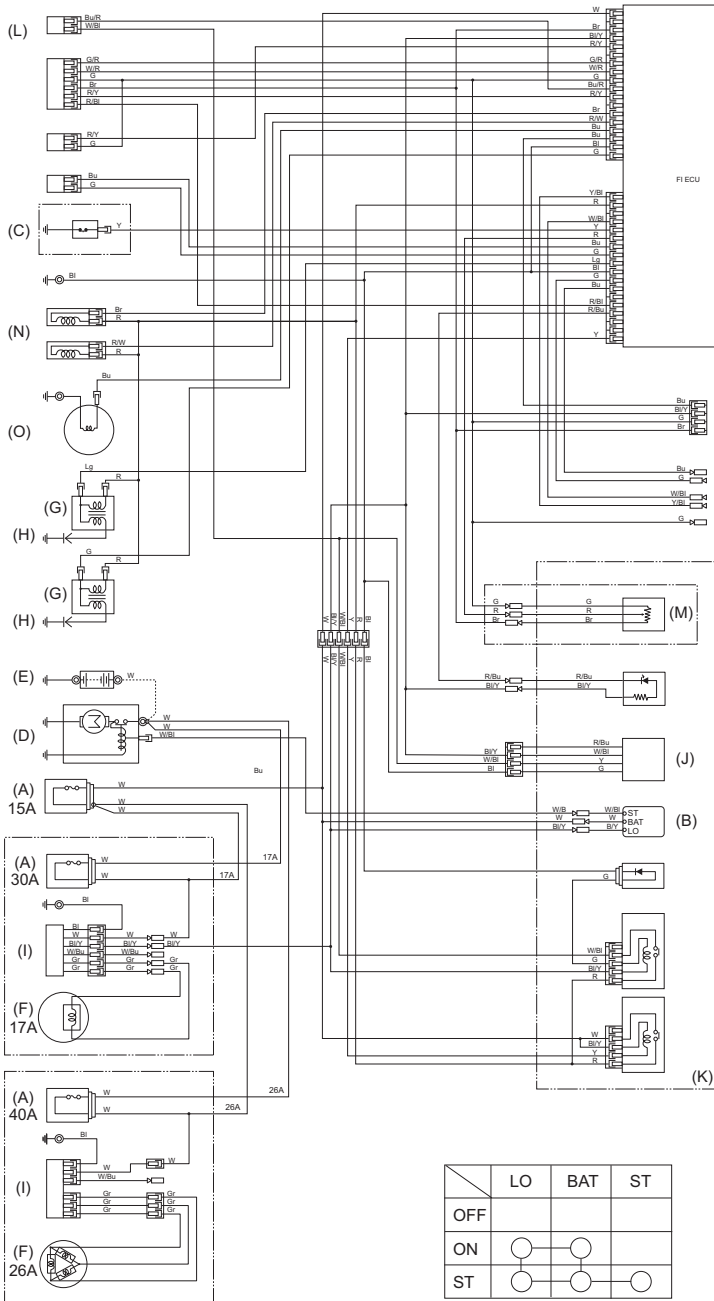

Without Control Box Type

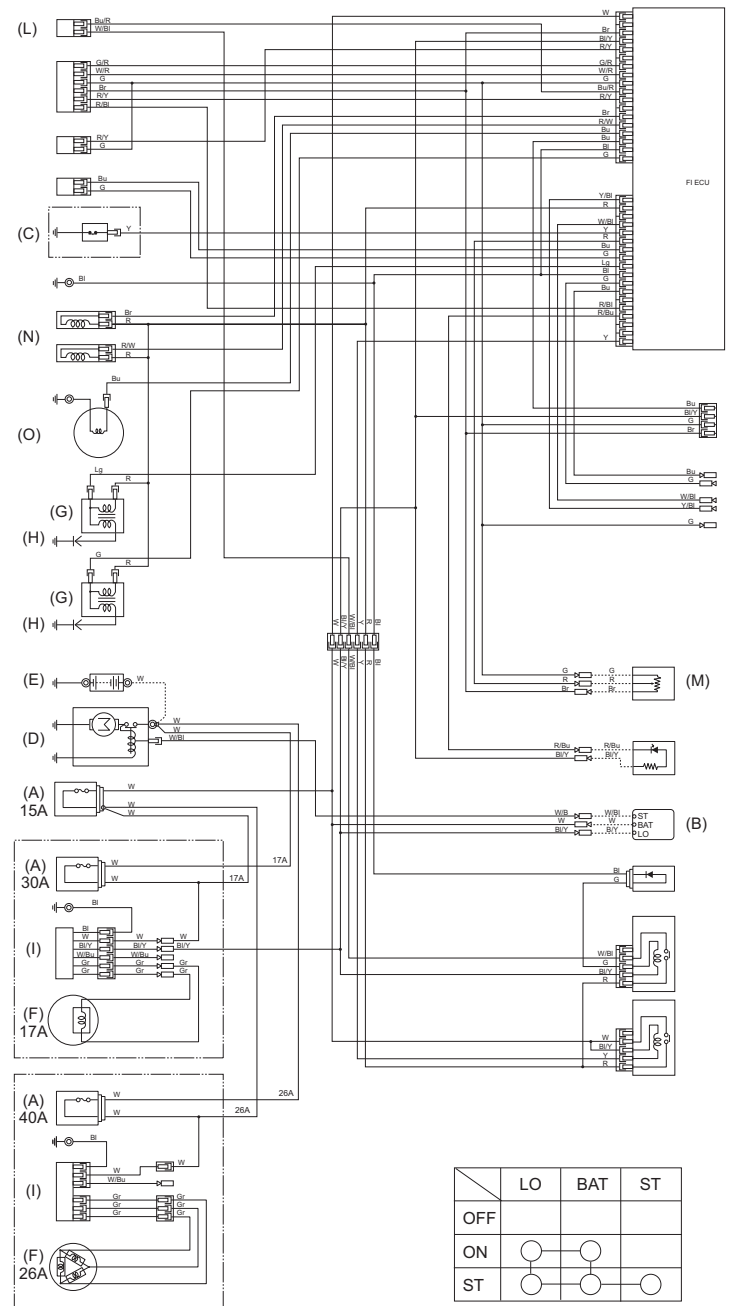

CONSUMER INFORMATION

Warranty and Distributor/Dealer Locator Information

United States, Puerto Rico, and U.S. Virgin Islands:

Visit our website: www.honda-engines.com

Canada:

Call (888) 9HONDA9

or visit our website: www.honda.ca

For European Area:

Visit our website: <http://www.honda-engines-eu.com>

Customer Service Information

Servicing dealership personnel are trained professionals. They should be able to answer any question you may have. If you encounter a problem that your dealer does not solve to your satisfaction, please discuss it with the dealership's management. The Service Manager, General Manager, or Owner can help. Almost all problems are solved in this way.

United States, Puerto Rico, and U.S. Virgin Islands:

If you are dissatisfied with the decision made by the dealership's management, contact the Honda Regional Engine Distributor for your area.

If you are still dissatisfied after speaking with the Regional Engine Distributor, you may contact the Honda Office as shown.

All Other Areas:

If you are dissatisfied with the decision made by the dealership's management, contact the Honda Office as shown.

«Honda's Office»

When you write or call, please provide this information:

- Equipment manufacturer's name and model number that the engine is mounted on
- Engine model, serial number, and type (see page 13)
- Name of dealer who sold the engine to you
- Name, address, and contact person of the dealer who services your engine
- Date of purchase
- Your name, address and telephone number
- A detailed description of the problem

United States, Puerto Rico, and U.S. Virgin Islands:

American Honda Motor Co., Inc.

Power Equipment Division

Customer Relations Office

4900 Marconi Drive

Alpharetta, GA 30005-8847

Or telephone: (770) 497-6400, 8:30 am - 7:00 pm ET

Canada:

Honda Canada, Inc.

Please visit www.honda.ca

for address information

Telephone: (888) 9HONDA9 Toll free

(888) 946-6329

Facsimile: (877) 939-0909 Toll free

For European Area:

Honda Motor Europe Logistics NV.

European Engine Center

<http://www.honda-engines-eu.com>

All Other Areas:

Please contact the Honda distributor in your area for assistance.

Honda General Purpose Engine International Warranty

The Honda General Purpose Engine installed on this brand product is covered by a Honda General Purpose Engine Warranty, on the following assumptions.

- The warranty conditions conform to those for the general purpose engine established by Honda for each country.
- The warranty conditions apply to engine failures caused by any manufacturing or specification problem.
- The warranty does not apply to countries where there is no Honda distributor.

To obtain warranty service:

You must take your Honda general purpose engine, or the equipment in which it is installed, together with proof of original retail purchase date to a Honda engine dealer authorized to sell that product in your country or the dealer who you purchased your product from. To locate a Honda distributor/dealer near you or check warranty condition in your country, visit our global service information website

<https://www.hondappsv.com/ENG/> or contact distributor in your country.

Exclusions:

This engine warranty does not include the following:

1. Any damage or deterioration resulting from the following:
 - Neglect of the periodic maintenance as specified in the engine owner's manual
 - Improper repair or maintenance
 - Operating methods other than those indicated in the engine owner's manual
 - Damage caused by the product on which the engine is installed
 - Damage caused by conversion to, or use of, fuel other than the fuel(s) that the engine was originally manufactured to use, as set forth in the engine owner's manual and/or warranty booklet
 - The use of non-genuine Honda parts and accessories, other than those approved by Honda (other than recommended lubricants and fluids) (does not apply to the emissions warranty unless non-genuine part used is not comparable to Honda part and was cause of the failure)
 - Exposure of the product to soot and smoke, chemical agents, bird droppings, sea water, sea breeze, salt or other environmental phenomena
 - Collision, fuel contamination or deterioration, neglect, unauthorized alteration, or misuse
 - Natural wear and tear (natural fading of painted or plated surfaces, sheet peeling and other natural deterioration)
2. Consumable parts: Honda does not warrant parts deterioration due to normal wear and tear. The parts listed below are not covered by warranty (unless they are needed as a part of another warranty repair):
 - Spark plug, fuel filter, air cleaner element, clutch disc, recoil starter rope
 - Lubricant: oil and grease
3. Cleaning, adjustment, and normal periodic maintenance work (carburetor cleaning and engine oil draining).
4. Use of the Honda general purpose engine for racing or competition.
5. Any engine that is part of a product that has ever been declared a total loss or sold for salvage by a financial institution or insurer.

About SERVICE & SUPPORT Label

There may be the SERVICE & SUPPORT label* affixed to the Honda General Purpose Engine. As you visit our website by scanning this two-dimensional barcode (QR code), you will find service information.
* This label is not affixed to all models.



https://www.hondappsv.com/ENG/QR/GX700_800/

HONDA