

HONDA HHH25D/HHH25S

OWNER'S MANUAL

Original instructions

MANUEL DE L'UTILISATEUR

Notice originale

BEDIENUNGSANLEITUNG

Originalbetriebsanleitung

MANUAL DE EXPLICACIONES

Manual original

Thank you for purchasing a Honda hedge trimmer.

This manual covers the operation and maintenance of the Honda hedge trimmer HHH25D/HHH25S.

Honda Motor Co., Ltd. reserves the right to make changes at any time without notice and without incurring any obligation.

No part of this publication may be reproduced without written permission.

This manual should be considered a permanent part of the hedge trimmer and should remain with it if it is resold.

Pay special attention to statements preceded by the following words;

⚠ WARNING Indicates a strong possibility of severe personal injury or death if instructions are not followed.

CAUTION: Indicates a possibility of personal injury or equipment damage if instructions are not followed.

NOTE: Gives helpful information.

If a problem should arise, or if you have any questions about the hedge trimmer, consult an authorized Honda dealer.

Honda hedge trimmers are designed to give safe and dependable service if operated according to instructions.

⚠ WARNING Operating a hedge trimmer requires special effort to ensure the safety of the operator and the safety of others. Read and understand this Owner's Manual before operating the hedge trimmer; failure to do so could result in personal injury or equipment damage.

- Illustrations herein are mainly based on: HHH25D

Disposal

To protect the environment, do not dispose of this product, battery, engine oil, etc. carelessly by leaving them in the waste. Observe the local laws and regulations or consult your authorized Honda dealer for disposal.

CONTENTS

1. SAFETY INSTRUCTIONS	3
2. SAFETY LABEL LOCATIONS.....	15
CE mark and noise label locations.....	16
3. COMPONENT IDENTIFICATION	19
4. CONTROLS	22
5. PRE-OPERATION CHECKS	25
6. STARTING THE ENGINE	34
Carburetor Modification for High Altitude Operation	38
7. TRIMMING OPERATION	39
8. STOPPING THE ENGINE	43
9. MAINTENANCE.....	44
10. STORAGE	57
11. TROUBLESHOOTING	59
12. SPECIFICATIONS	60
MAJOR Honda DISTRIBUTOR ADDRESSES	Inside back cover
“EC Declaration of Conformity”	
CONTENT OUTLINE.....	Inside back cover

1. SAFETY INSTRUCTIONS

⚠ WARNING

To ensure safe operation

For your safety and safety of others, pay special attention to these precautions:

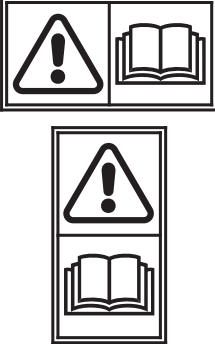

- Honda hedge trimmer is designed to give safe and dependable service if operated according to instructions. Read and understand this Owner's Manual before operating the hedge trimmer. Failure to do so could result in personal injury or equipment damage.



- Exhaust contains poisonous carbon monoxide, a colorless, odorless gas. Breathing carbon monoxide can cause loss of consciousness and may lead to death.
- If you run the hedge trimmer in an area that is confined, or even partially enclosed area, the air you breathe could contain a dangerous amount of exhaust gas.
- Never run your hedge trimmer inside a garage, house or near open windows or doors.



- Gasoline is extremely flammable and is explosive under certain conditions.
- Do not smoke or allow flames or sparks in the area where the hedge trimmer is refueled or where gasoline is stored.
- Do not overfill the fuel tank, and make sure the fuel tank cap is closed securely after refueling.
- Refuel in a well-ventilated area with the engine stopped.



- Keep all persons and pets away from the hedge trimmer operating area.
- To prevent accidental contacts with the operating cutter blade or thrown objects from the operating cutter blade, keep people and pets at least 4.5 m (15 ft.) away from the hedge trimmer when it is in use.



- Wear eye protection, helmet and other protective devices to protect your eyes and body from all objects (gravel, glass, wire, etc.) thrown by the operating cutter blade.

⚠ WARNING

To ensure safe operation

Operator Responsibility

- Any part from the machine is a potential source of danger if the machine is used in abnormal conditions or if the maintenance is not done correctly.
- Read the owner's manual carefully. Be familiar with the controls and their proper use of the hedge trimmer. Know how to stop the engine rapidly.
- Use the hedge trimmer for the purpose it is intended for, that is trimming for hedge.
Any other use could be dangerous or damage the hedge trimmer. Do not use the hedge trimmer as a pruning hook.
- Never allow children or people unfamiliar with this owner's manual to use the hedge trimmer. Local regulations may restrict the age of the operator.
- If you lend or resell your hedge trimmer to a third person, instruct him or her with how to handle the product and alert him or her to read and understand the Owner's Manual carefully before operation.
- Never operate the hedge trimmer while:
 - people, especially children or pets are nearby.
 - user is fatigued or under medication, or has swallowed substances known to affect judgement or reactions.
- Keep people and pets at least 4.5 m (15 ft.) away from the operator during operation. Note that an assistant to the operator should work at least 4.5 m (15 ft.) away from the operator, too. We recommend to decide the engine stop signal and other signals between the operator and assistant, and use them for safety during operation.
- Keep in mind that the operator or user is responsible for accidents or hazards occurring to other people or their property.

⚠ WARNING

To ensure safe operation

Operator Responsibility

- While operating the hedge trimmer, always wear following protective clothing and protective devices.
 - Protective clothing
 - Wear adequate clothes with long sleeves and long pants. The clothes must fit your body and button up or zip up the clothes securely. Do not leave the sleeves and bottom of the shirt/jacket loose. Wear the arm covers, too.
 - Do not wear the clothes with the tapes, laces and/or ribbons, loose clothes, necktie, necklace, etc. during operation. They can be caught in the hedge trimmer or on the weed causing injury. Bind your hair if it is long, and do not let your hair below your shoulder.
 - Protective devices
 - * Goggles
 - Wear the goggles or other eye protection to protect your eyes from the debris that is thrown by the operating cutter blade.
 - * Helmet
 - Wear the helmet to protect your head from the overhead branches and the falling foreign material.
 - * Face shield
 - Wear face shield to protect your face from the debris thrown by the operating cutter blade.
 - * Ear muffs/ear plugs
 - Wear the ear muff, ear plugs or other hearing protection to protect your ears from the noise.
 - * Gloves
 - Wear the gloves to protect your hands.
 - * Safety boots
 - Wear the safety boots with the non-slip sole and toe protector to protect your feet from the flying debris.
 - Do not operate the equipment when barefoot or wearing open sandals.
 - Wear the leg protectors as well.

⚠ WARNING

To ensure safe operation

Operator Responsibility

* Dust mask

We recommend that you wear the dust mask if you suffer from the allergic rhinitis, e.g. pollinosis, etc. The dust mask is available at a pharmacy and it is helpful for reducing the amount of pollens you breathe.

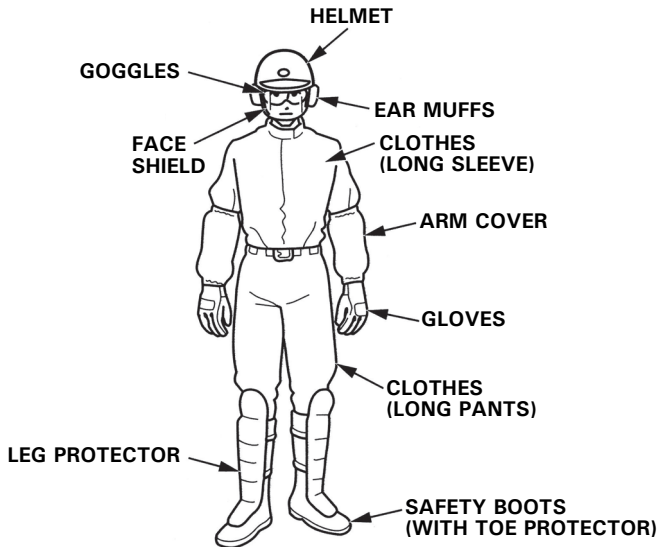

- Before each use, visually inspect the hedge trimmer for any damage and looseness of fastening part.
- Before each use, look around and underneath the engine for signs of oil or gasoline leaks.
- Avoid operating the hedge trimmer at night or in a bad weather of poor visibility, because there is much possibility of accident.
- Walk, never run during operation.
- Avoid operating the hedge trimmer on a steep slope.
The steep slope is very slippery, so you can slip down.

⚠ WARNING

To ensure safe operation

Operator Responsibility

- Do not operate the hedge trimmer with the labels, and other parts removed.
- Do not mount an incorrect part and do not tamper with the hedge trimmer as it can result in personal injury and/or equipment damage.
- Before cranking the engine, be sure to check the cutter blade cannot come into contact with the ground or any obstruction.
- Start the engine carefully according to instructions and with hands and feet well away from the cutter blade.
- Start the hedge trimmer on a level surface, free of high grass or obstacle.
- Do not press the hedge trimmer on a tree, etc. Match the motion and speed of the cutter blade and work.
- Never carry the hedge trimmer while it is operating. Before you carry the hedge trimmer, be sure to stop the engine and confirm the cutter blade stops. Cover the blade with the protective plastic cover while carrying the trimmer.
- When the engine is hot, keep away from the muffler to avoid getting burned.
When you carry the hedge trimmer, keep it away from your body, because the muffler is hot.

⚠ WARNING

To ensure safe operation

Operator Responsibility

- Stop the engine and make sure that the engine switch is in the OFF position in the following cases:
 - Before any operation around the cutter blade.
 - Before checking, cleaning or working on the hedge trimmer.
 - After striking a foreign object. Inspect the hedge trimmer for damage and make repairs before restarting and operating the hedge trimmer again.
 - If hedge trimmer starts to vibrate abnormally. Check immediately the cause of the vibration and perform the necessary repair.
- Turn the engine switch to the OFF position and stop the engine in the following cases:
 - Whenever you leave the hedge trimmer unattended.
 - Before refueling.
 - When any person or pet is approaching.
 - Shut off the engine immediately when the hedge trimmer shows abnormal vibration suddenly. Sudden vibration can suggest the damaged sliding parts or loose fasteners. Examine the cause of the problem, and do not start the engine before repair is made.
 - Shut off the engine immediately when, after returning the throttle lever, the cutter blade still operates. Examine the cause of the problem, and do not start the engine before repair is made.
 - When a wire catches on the cutter blade. Remove the wire after stopping the engine. If you remove it without stopping the engine, the cutter blade starts to operate and you may get injured.
 - Before placing the hedge trimmer on the ground, make sure the cutter blade stops turning as well.
Note that the cutter blade is operating by inertia right after returning the throttle lever and while the engine is idling.

⚠ WARNING

To ensure safe operation

Operator Responsibility

- Be careful not to cut anything hard such as a wire or iron plate. It causes a failure or accident.
If the hedge trimmer should touch an obstacle, stop the engine immediately and check if there is a problem with the cutter blade. If the cutter blade has any damage such as cracks, bent, discoloration because of extreme heat, and excessive wear, do not use it.
If you use a cracked cutter blade, broken pieces of the blade may fly away.
- The hedge trimmer is faulty when the engine is idling by returning the throttle but the cutter blade keeps moving. Stop the engine immediately and idle speed adjustment must be made. Consult your authorized Honda dealer.
- Keep all nuts, bolts and screws tight to be sure the hedge trimmer is in safe working condition. Regular maintenance is an essential aid to user's safety and retaining a high level of performance.
- Do not use the hedge trimmer with worn or damaged parts. Parts must be replaced, or repaired. Replace worn or damaged parts with Honda genuine parts. Non equivalent quality parts may damage the machine and be prejudicial to your safety.
- Hold the hedge trimmer firmly with both your hands during operation to keep the trimmer under control at all times.
- Trim a hedge with the cutter blade facing outward.
Do not turn the cutter blade or bring it closer to your body.
- Do not use the hedge trimmer, reaching out. Do not use it on a ladder, a table or other unstable places.

⚠ WARNING

To ensure safe operation

Operator Responsibility

- Injury caused by vibration and cold:
You may feel the prickling or burning pain in your fingers, and the fingers may lose color and feeling depending on your constitution. It is believed that these symptoms are brought by vibration and/or exposure to cold. The specific trigger point of these symptoms are not identified yet, but observe the following instructions.
 - * Limit the amount of time you spend operating the hedge trimmer in a day.
A day's work should consist of the work with the hedge trimmer and the other work without the hand-held equipment so you can limit the amount of time when your hands are exposed to the machine vibration.
 - * Keep your body warm, especially your hands, wrists and arms.
 - * Take your breaks at shorter intervals and arm exercises well to maintain good blood circulation. Do not smoke while working.
 - * When you feel discomfort, redness and swelling of the fingers followed by whitening and loss of feeling, consult your doctor promptly.
- Injury caused by repeated operation:
Performing the repeated operation for a prolonged time may cause injury. Observe the following instructions to reduce the causes of the injury.
 - * Avoid the repeated operation by using your wrist(s) in bent, stretched or twisted position.
 - * Take your breaks regularly to minimize the effect of the repeated operation. Take your time when performing the repeated operation. Do not rush to operate the hedge trimmer.
 - * When your fingers, hands, wrists and/or arms are throbbing or numbed, consult your doctor.

⚠ WARNING**To ensure safe operation****Child Safety**

- Keep children indoors and supervised at all times when any outdoor power hedge trimmer is being used nearby. Young children move quickly and are attracted especially to the hedge trimmer and trimming activity.
- Never assume children will remain where you last saw them. Be alert and turn the hedge trimmer off if children enter the area.
- Children should never be allowed to operate the hedge trimmer, even under adult supervision.

Thrown Object Hazard

Objects hit by the operating cutter blade can be thrown from the hedge trimmer with great force, and may cause serious injury.

- Thoroughly inspect the area where the hedge trimmer is to be used and remove all objects (stones, branches, wires, bones, etc ...) which may be thrown by the operating cutter blade.

⚠ WARNING

To ensure safe operation

Fire and Burn Hazard

Gasoline is extremely flammable, and gasoline vapor can explode. Use extreme care when handling gasoline. Keep gasoline out of reach of children.

- Store fuel in containers specifically designed for this purpose.
- Refuel outdoors only, and do not smoke while refueling or handling fuel.
- Add fuel before starting the engine. Never remove the cap of the fuel tank or add gasoline while the engine is running or when the engine is hot.
- If gasoline is spilled, do not attempt to start the engine but move the hedge trimmer away from the area of spillage and avoid creating any source of ignition until gasoline vapours have dissipated.
- Tighten all fuel tanks and container caps securely.
- When you start the engine after refueling, be sure to start the engine at least 3 m (10 ft.) away from the refueling spot.
- Never store the hedge trimmer with gasoline in the tank inside a building where fumes may reach an open flame, spark or high temperature source.
- Allow the engine to cool before storing in any enclosure.
- To reduce the fire hazard, keep the hedge trimmer, especially the engine, muffler, the gasoline storage area as well, free of grass, leaves, or excessive grease.
Do not leave containers of vegetable matters in or near a building.
- If the fuel tank has to be drained, this should be done outdoors, with a cold engine.

⚠ WARNING

To ensure safe operation

Carbon Monoxide Poisoning Hazard

Exhaust contains poisonous carbon monoxide, a colorless and odorless gas. Breathing exhaust can cause loss of consciousness and may lead to death.

- If you run the engine in an area that is confined or even partially enclosed, the air you breathe could contain a dangerous amount of exhaust gas.
To keep exhaust gas from building up, provide adequate ventilation.
- Replace faulty muffler.
- Do not operate the engine in a confined space where dangerous carbon monoxide fumes can collect.

2. SAFETY LABEL LOCATIONS

Your hedge trimmer must be used with care. Therefore, decals have been placed on the machine, to remind you pictorially of main precautions to take during use. Their meanings are explained on page 3.

These decals are considered as a part of the hedge trimmer. Should one become detached or unreadable, contact your Honda dealer for its replacement.

HHH25D:

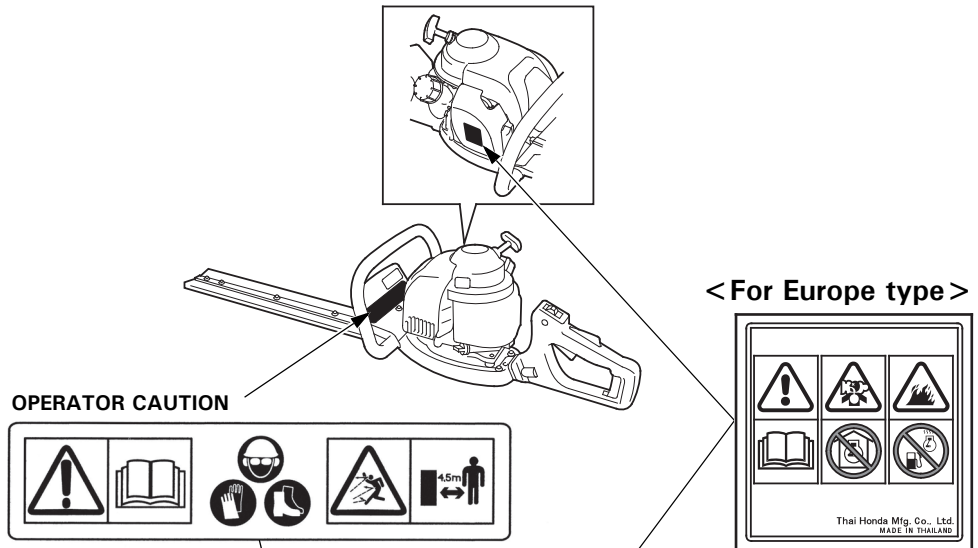

HHH25S:

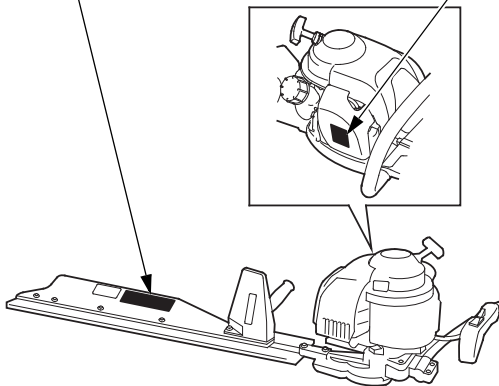

CE mark and noise label locations

HHH25D:

<For Europe type>

NOISE LABEL

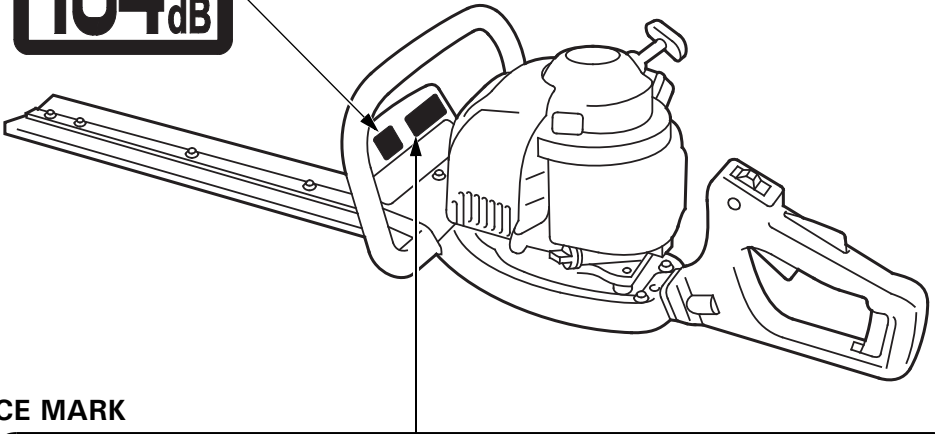

CE MARK

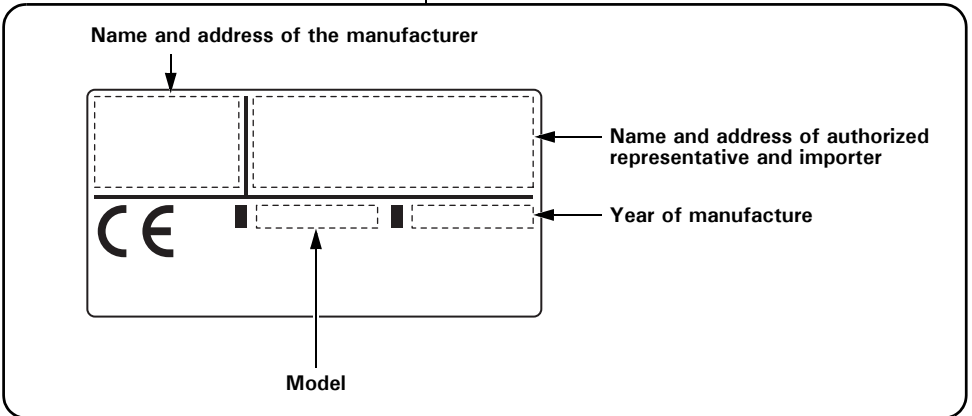

Name and address of manufacturer, authorized representative and importer are written in the "EC Declaration of Conformity" CONTENT OUTLINE in this Owner's Manual.

Noise label location

HHH25D:

< For Australia type >

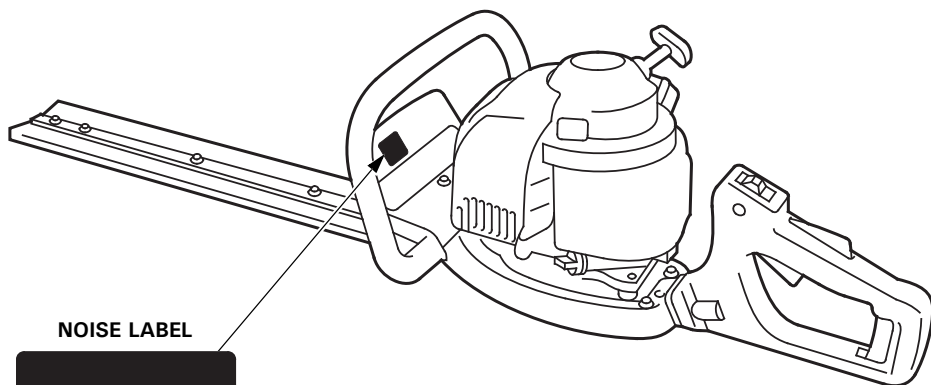

NOISE LABEL



CE mark and noise label locations

HHH25S:

<For Europe type>

NOISE LABEL

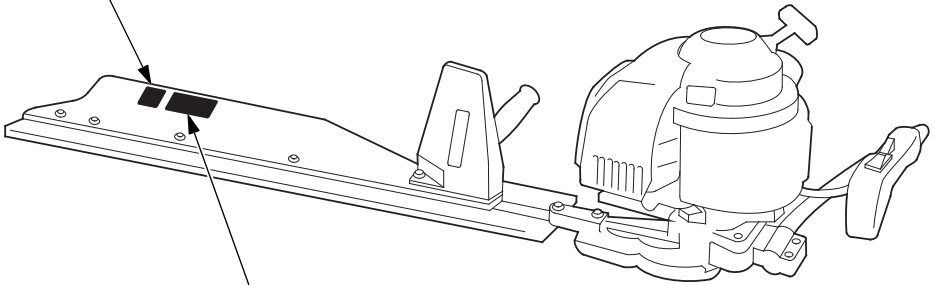

CE MARK

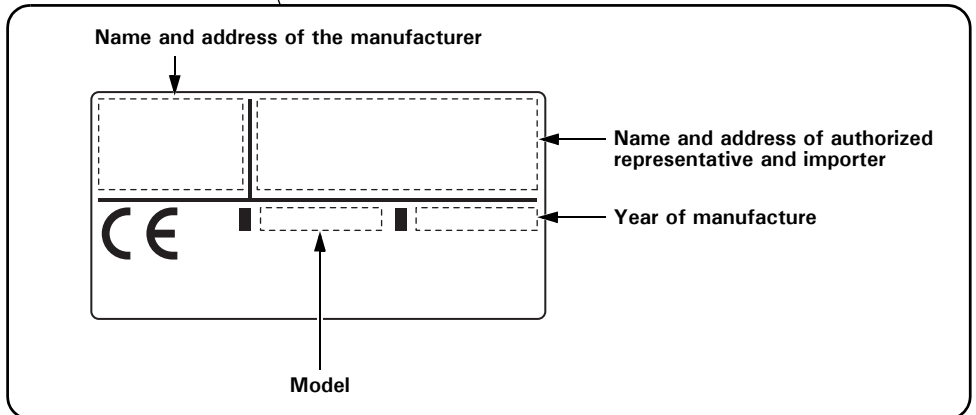

Name and address of manufacturer, authorized representative and importer are written in the "EC Declaration of Conformity" CONTENT OUTLINE in this Owner's Manual.

3. COMPONENT IDENTIFICATION

HHH25D:

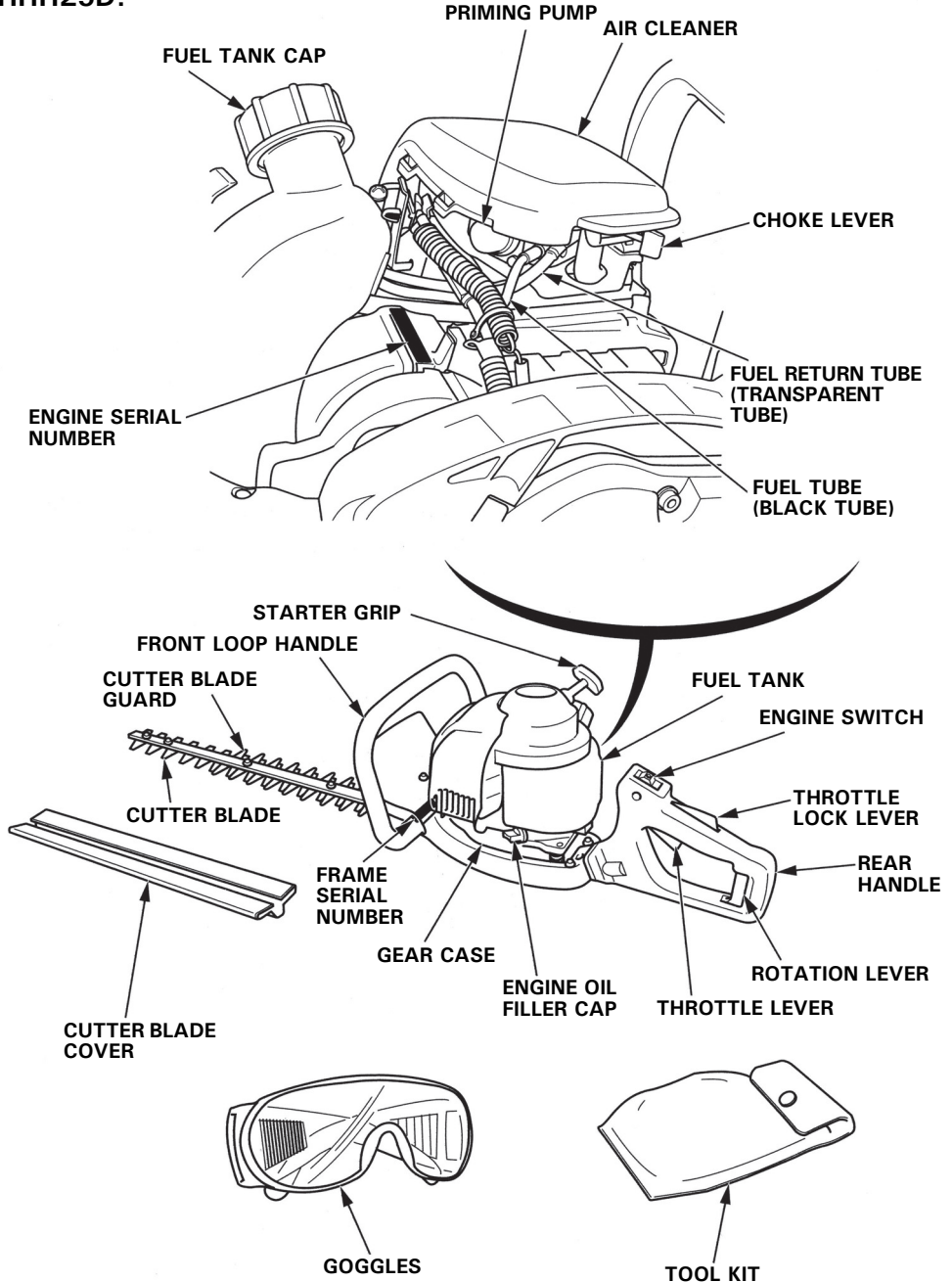

HHH25S:

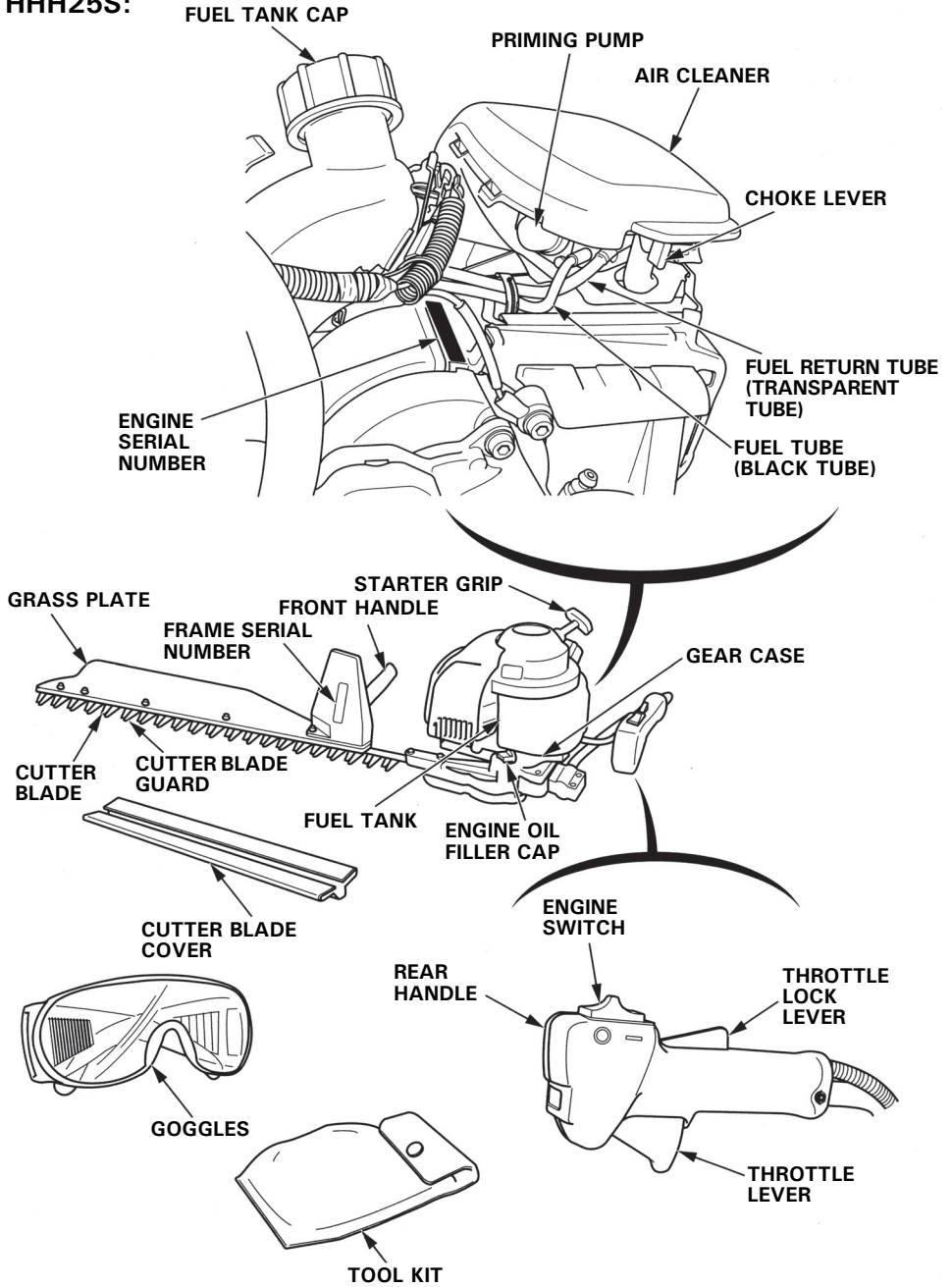

Record the frame serial number and engine serial number (see pages 19 or 20) in the space below. You will need these serial numbers when ordering parts, and when making technical or warranty inquiries.

Engine serial number: _____

Frame serial number: _____

4. CONTROLS

1. Engine switch

The engine switch enables and disables the ignition system.

The engine switch must be in the ON position for the engine to run.

Turning the engine switch to the OFF position stops the engine.

HHH25D:

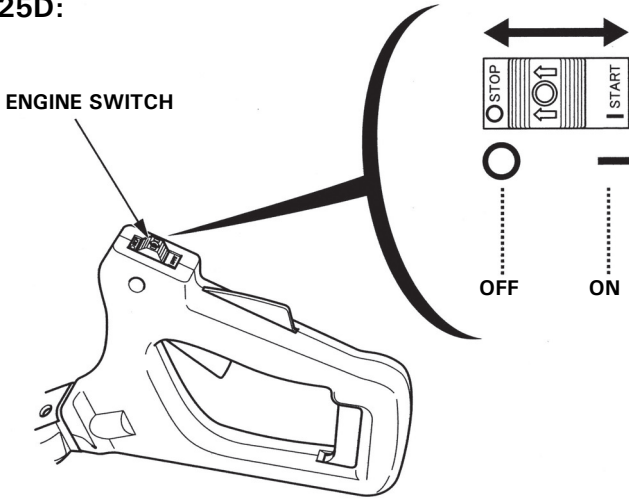

HHH25S:

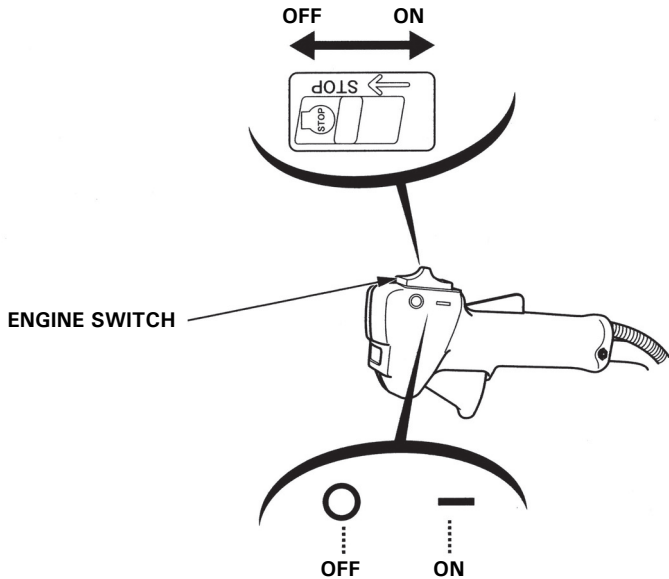

2. Choke lever

The choke lever opens and closes the choke valve in the carburetor.

The CLOSED position enriches the fuel mixture for starting a cold engine.

The OPEN position provides the correct fuel mixture for operation after starting, and for restarting a warm engine.

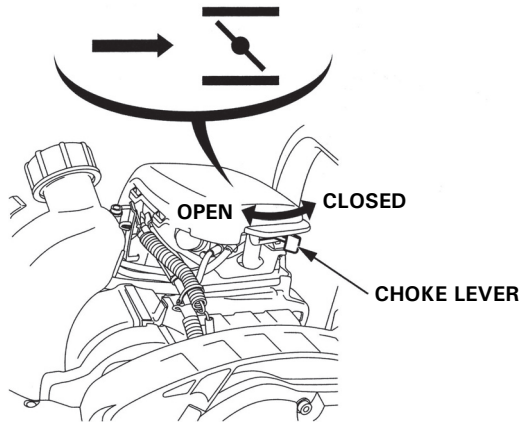

3. Recoil starter

Pulling the starter grip operates the recoil starter to crank the engine for starting.

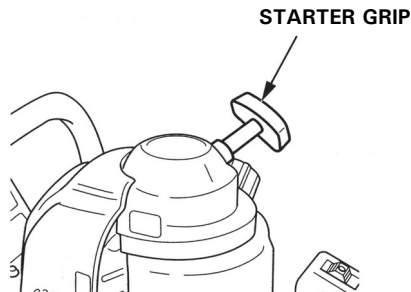

4. Throttle lever

The throttle lever controls engine speed.

Pulling and releasing the throttle lever shown below makes the engine run faster or slower.

NOTE:

The throttle lock lever interlock must be depressed before the throttle lever can be activated.

By pulling the throttle lever gradually, the engine speed increases and the cutter blade starts to move.

Pull the throttle lever more to accelerate the engine speed and the operating speed.

By releasing the throttle lever, the engine speed decreases and the cutter blade keeps operating for a while by inertia, then it stops.

Throttle lock lever:

The throttle lock lever makes the throttle lever operable. The throttle lever cannot be pulled unless the throttle lock lever has been pushed beforehand.

HHH25D:

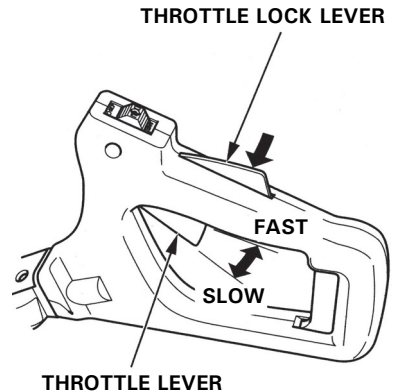

HHH25S:

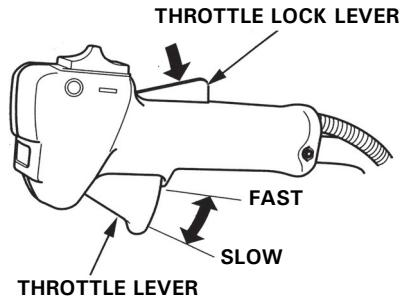

5. PRE-OPERATION CHECKS

For safe and efficient trimming, always make a pre-operation inspection before operating:

⚠ WARNING

Before performing a pre-operation inspection, place the hedge trimmer on a level surface, stop the engine and make sure that the engine switch is in the OFF position to be certain the engine will not start accidentally.

1. Check the engine oil level

CAUTION:

Running the engine with low oil level will cause serious engine damage.

1. Install the cutter blade cover, place the hedge trimmer vertically on a horizontal table, and hold the cutter blade.

HHH25D: Grip the rotation lever and rotate the rear handle 90° clockwise or counterclockwise. Place the hedge trimmer on a level surface and remove the oil filler cap.

HHH25D:

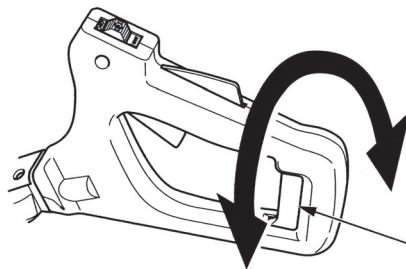
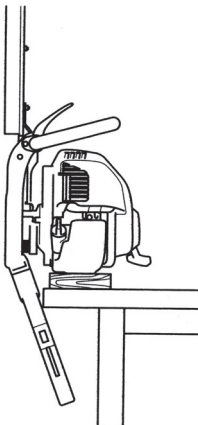

HHH25S:

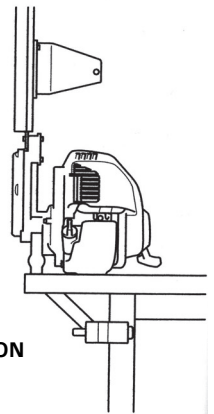

2. Check the oil level:

It should reach to the edge of the oil filler neck, and check the engine oil for contamination and deterioration.

3. If the oil level is low, fill to the edge of the oil filler neck with the recommended oil (see page 26).

If the oil is contaminated or deteriorated, replace it (see page 47).

4. Install the oil filler cap.

Every 10 hours, check the engine oil level and replenish oil up to the top of the oil filler neck if the engine is operated for more than 10 hours continuously.

ENGINE OIL CAPACITY: 0.08 L (0.08 US qt, 0.07 Imp qt)

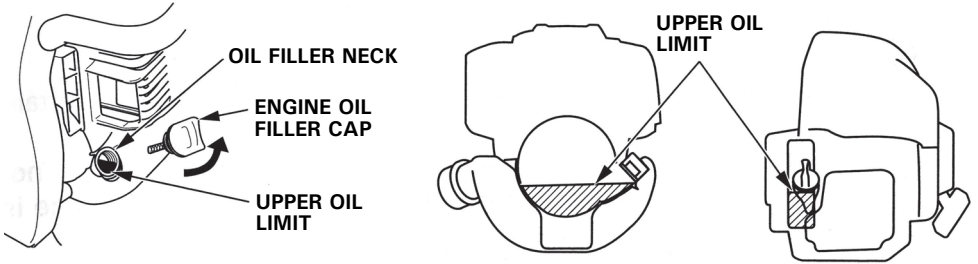

Use 4-stroke motor oil that meets or exceeds the requirements for API service classification SE or later (or equivalent). Always check the API service label on the oil container to be sure it includes the letters SE or later (or equivalent).

SAE 10W-30 is recommended for general use. Other viscosities shown in the chart may be used when the average temperature in your area is within the indicated range.

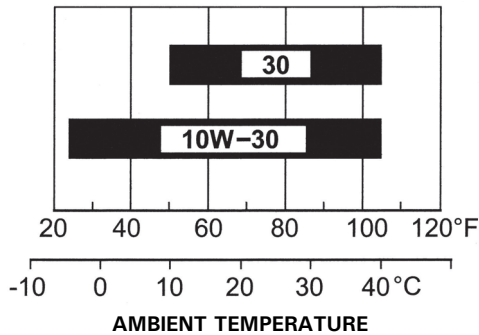

CAUTION:
Using nondetergent oil or 2-stroke engine oil could shorten the engine's service life.

2. Check the fuel level

Use automotive unleaded gasoline with a Research Octane Number of 91 or higher (a Pump Octane Number of 86 or higher).

Never use stale or contaminated gasoline or an oil/gasoline mixture.

Avoid getting dirt or water in the fuel tank.

⚠ WARNING

- **Gasoline is extremely flammable and is explosive under certain conditions.**
- **Refuel in a well-ventilated area with the engine stopped. Do not smoke or allow flames or sparks in the area where the engine is refueled or where gasoline is stored.**
- **Do not overfill the fuel tank (there should be no fuel in the filler neck). After refueling, make sure the tank cap is closed properly and securely.**
- **Be careful not to spill fuel when refueling. Spilled fuel or fuel vapor may ignite. If any fuel is spilled, make sure the area is dry before starting the engine.**
- **Avoid repeated or prolonged contact with skin or breathing of vapor. KEEP OUT OF REACH OF CHILDREN.**

CAUTION:

Gasoline substitutes are not recommended; they may be harmful to fuel system components.

Refuel in a well-ventilated area with the engine stopped. If the engine has been running, allow it to cool first. Never refuel the engine inside a building where gasoline fumes may reach flames or sparks.

1. Place the hedge trimmer horizontally, and check the outside of the tank if the fuel reaches the upper fuel level.
2. If the fuel level is low, refuel the fuel tank until the level as specified. Remove the fuel tank cap gradually to release a pressurized air in the fuel tank. Fuel in the fuel tank may spout out, if the fuel tank cap is removed quickly.

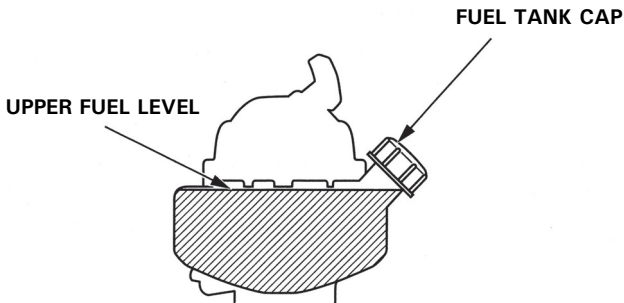
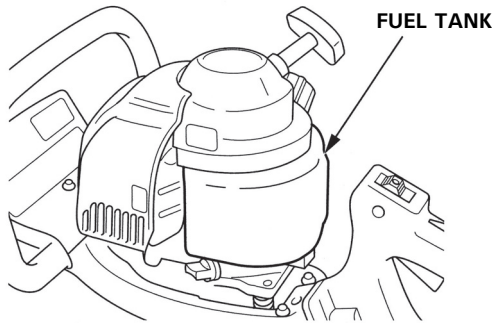

NOTE:

Gasoline spoils very quickly depending on factors such as light exposure, temperature and time.

In worst cases, gasoline can be contaminated within 30 days. Using contaminated gasoline can seriously damage the engine (carburetor clogged, valve stuck).

Such damage due to spoiled fuel is disallowed from coverage by the warranty.

To avoid this please strictly follow these recommendations:

- Only use specified gasoline (see page 27).
- Use fresh and clean gasoline.
- To slow deterioration, keep gasoline in a certified fuel container.
- If long storage (more than 30 days) is foreseen, drain fuel tank and carburetor (see page 57).

Gasoline containing alcohol

If you decide to use a gasoline containing alcohol (gasohol), be sure its octane rating is at least as high as that recommended by Honda.

There are two types of "gasohol": one containing ethanol, and the other containing methanol.

Do not use gasohol that contains more than 10% ethanol.

Do not use gasoline containing more than 5% methanol (methyl or wood alcohol) and that does not also contain co-solvents and corrosion inhibitors for methanol.

NOTE:

- Fuel system damage or engine performance problems resulting from the use of gasoline that contains more alcohol than recommended is not covered under the warranty.
- Before buying gasoline from an unfamiliar station, first determine if the gasoline contains alcohol, if it does, find out the type and percentage of alcohol used.

If you notice any undesirable operating symptoms while using a particular gasoline. Switch to a gasoline that you know contains less than the recommended amount of alcohol.

3. Check the air cleaner elements

CAUTION:

Never run the engine without the air cleaner; rapid engine wear will result.

1. Move the choke lever to the CLOSED position (see page 23).
2. Remove the air cleaner cover by unhooking the right tab on the right of the air cleaner cover and its two left tabs.
3. Check the air cleaner element for dirt or obstruction.
Clean the air cleaner element, if it is dirty (see page 49).
4. Reinstall the air cleaner element.
5. Reinstall the air cleaner cover by inserting the left tabs, then insert the right tab.

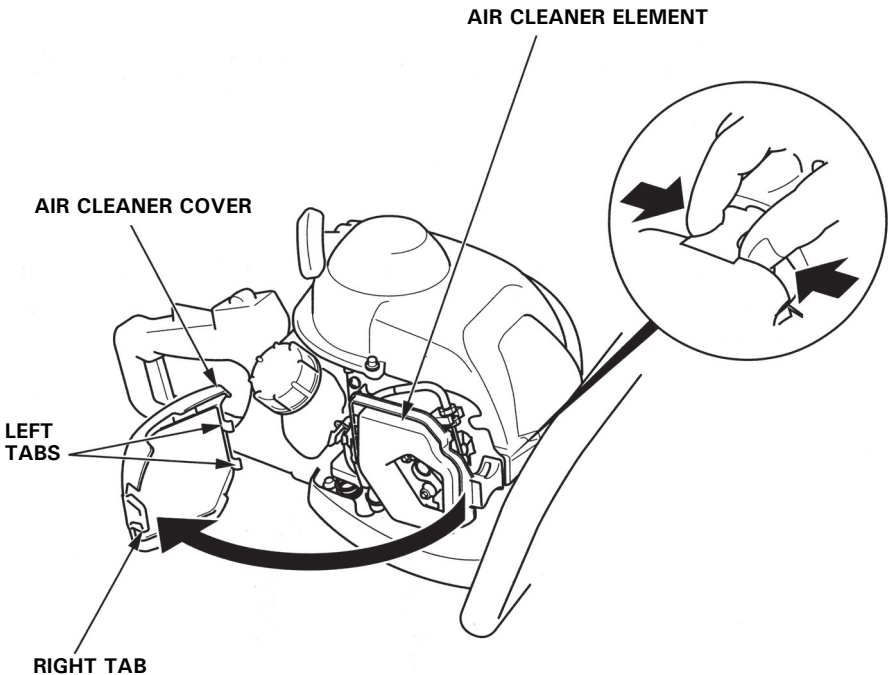

4. Check the throttle cable free play

- Check the throttle cable free play at the tip of the cable by pulling and releasing the throttle lever a few times. It should be 0.5 – 2.5 mm (0.02 – 0.10 in.) at the tip of the throttle cable.

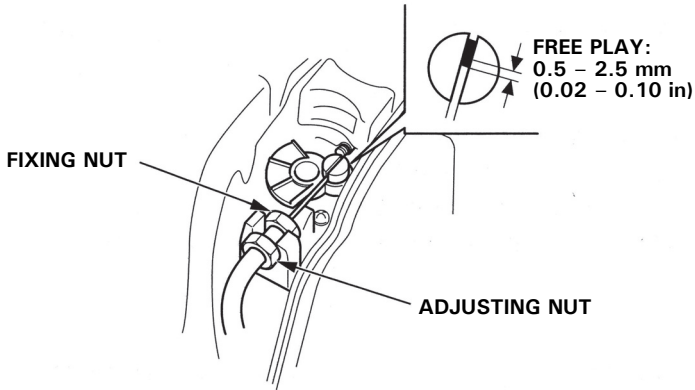

- Check the throttle lever operates smoothly and always spring back to the idle position.

5. Check the rear handle (HHH25D)

- Check the rear handle turns smoothly with the rotation lever squeezed.
- Check the rotation lever locks at the center, left, and right positions with the lever released.

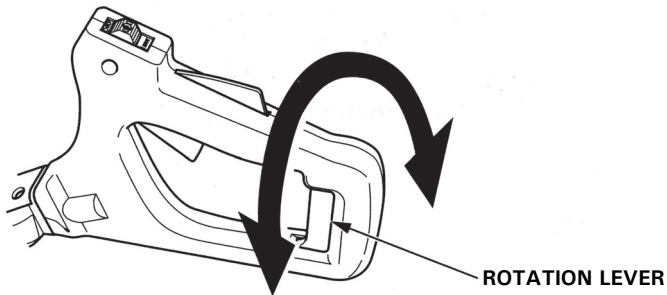

6. Cutter blade inspection

⚠ WARNING

For safety, check the blade for wear and damage and check the tightness of the bolts and nuts before starting the engine. Operating the hedge trimmer with a worn, cracked, or damaged blade can cause a personal injury or equipment damage. A worn, cracked or damaged blade can break and pieces of the damaged blade can hit the operator or bystanders causing death or serious injury.

CAUTION:

Wear heavy gloves to protect your hands, when working around the blade.

1. Stop the engine and make sure that the engine switch is in the OFF position.
2. Remove the cutter blade cover with heavy gloves on your hands.
3. Check the bolts and the nuts for looseness. Tighten up the bolts and nuts if they are loose. If you cannot do it properly, consult an authorized Honda dealer.

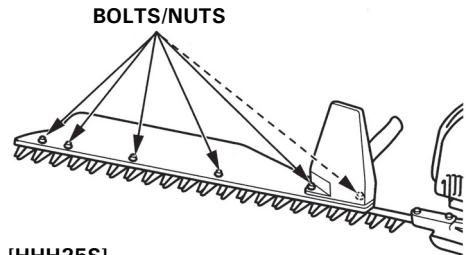
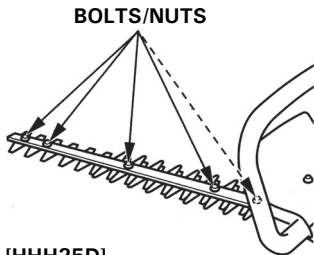

4. Check the blade and guard for wear, bend, crack, discoloration from heat, and other damage. If there is a problem with them, consult an authorized Honda dealer.



7. Check all bolts and nuts

1. Check each bolt and nut for looseness. Tighten them securely if necessary.
2. Check the handle for loose mounting bolts or screws, and tighten them securely if necessary.

HHH25D:

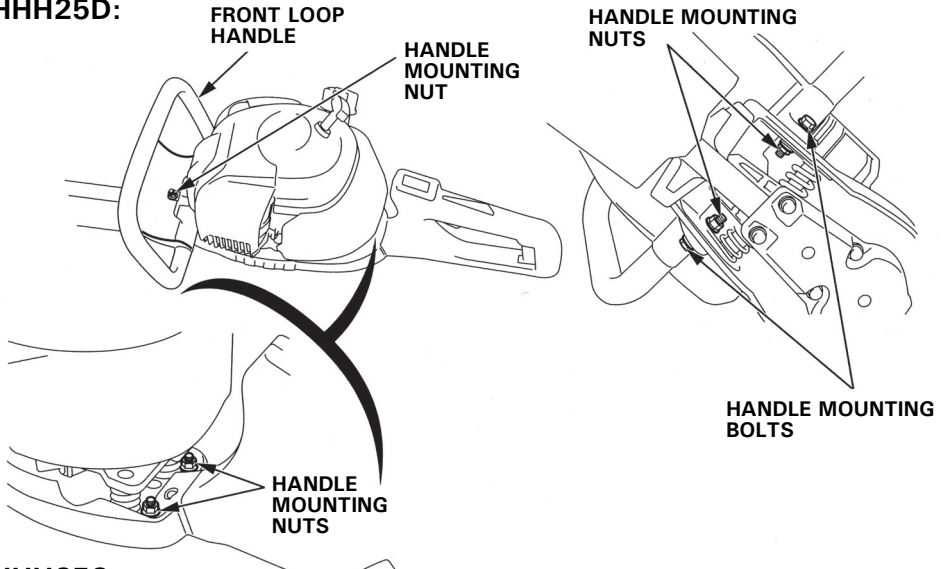

HHH25S:

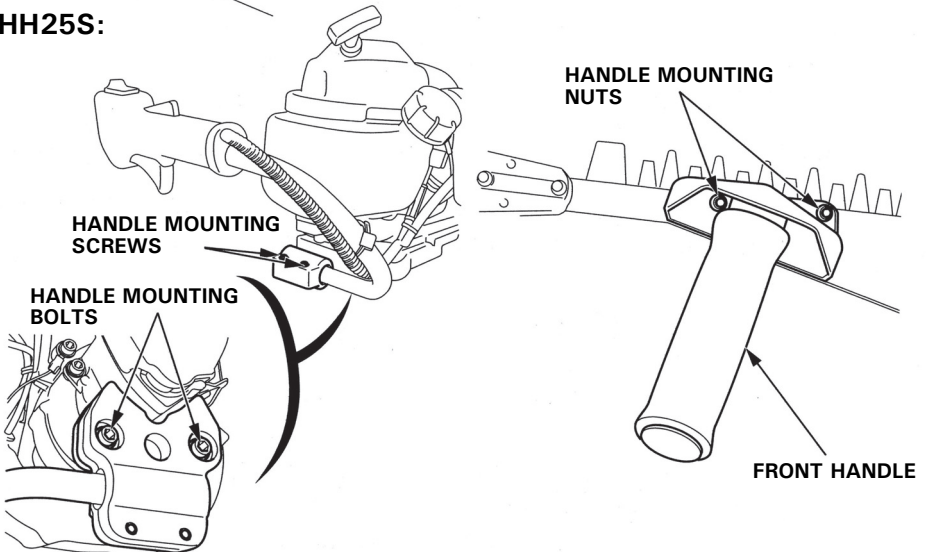

6. STARTING THE ENGINE

⚠ WARNING

- Exhaust gas contains poisonous carbon monoxide. Never run the engine in an enclosed area. Be sure to provide adequate ventilation.
- Start the engine in a place away from the people, pets, and surrounding buildings. Be sure there are no obstacles in the working area.

CAUTION:

Do not start the engine with the hedge trimmer off the ground. The trimmer can make unexpected movement causing injury in your legs, etc.

NOTE:

Place the hedge trimmer in an area free from the obstacles, and be sure the cutter blade is not in contact with the ground and other materials.

1. Remove the cutter blade cover from the hedge trimmer.
2. Turn the engine switch to the ON position.

HHH25D:

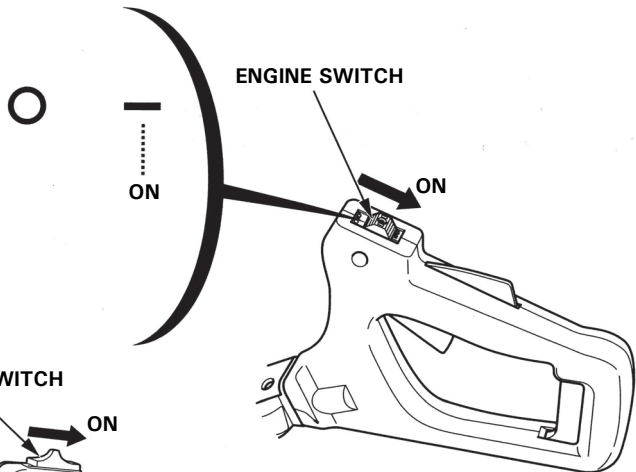

HHH25S:

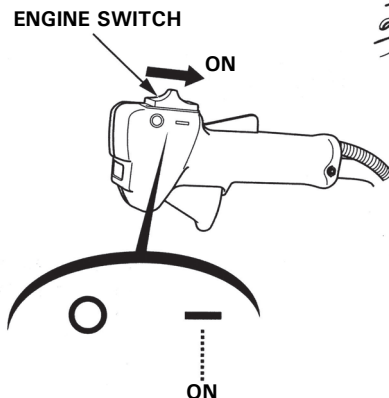

3. To start a cold engine, move the choke lever to the CLOSED position.

To restart warm engine, leave the choke lever in the OPEN position.

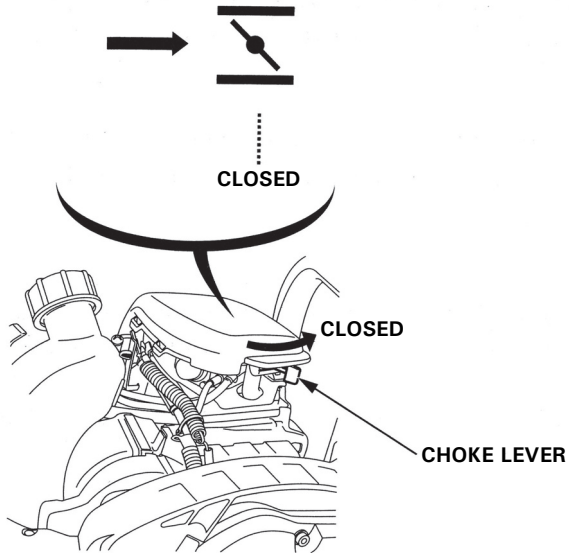

4. Press the priming pump several times until a flow in the fuel return tube (transparent tube) is visually noticed.

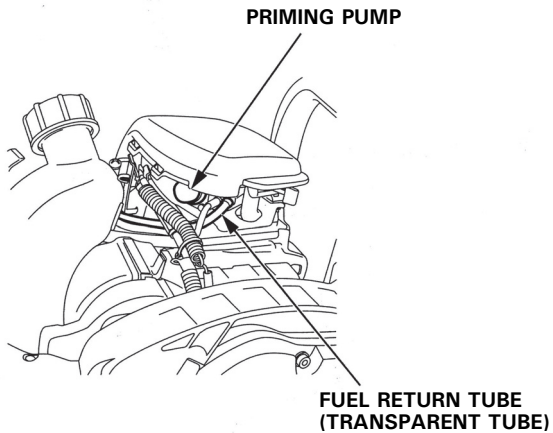

5. Pull the starter grip lightly until you feel resistance while holding the handle, then pull briskly in the direction of the arrow as shown below. Return the starter grip gently.

Be sure that the people and pets are away from the hedge trimmer especially behind you, before pulling the starter grip.

HHH25D:

OPERATOR'S POSITION
(back right of the hedge trimmer)

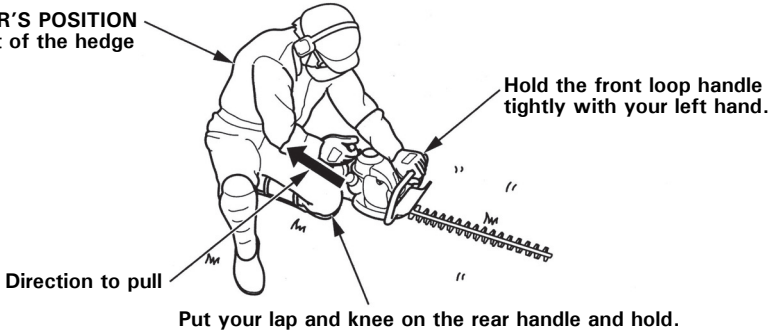

HHH25S:

OPERATOR'S POSITION
(back right of the hedge trimmer)

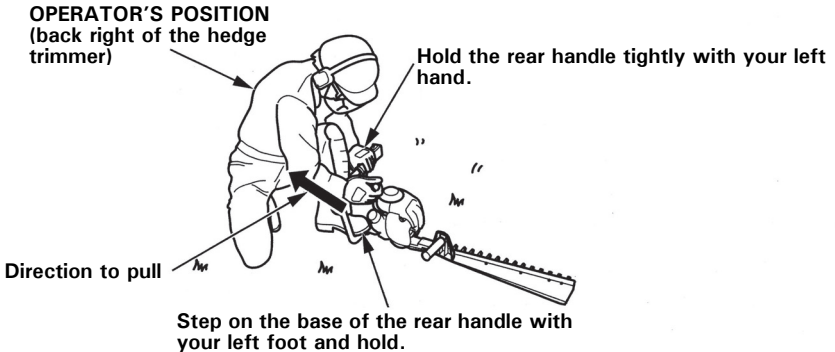

CAUTION:

- Pull the starter grip strongly. When the engine speed increases at the starting, the ignition spark reaches the engine. If the engine speed is slow, the engine may not start.
- Do not release the starter grip at the point where you pull it up fully, in order to prevent the grip from hitting the neighboring parts.
- Do not pull the recoil to prevent the engine from breaking down while the engine is operating.
- Do not operate the throttle lever when you pull the recoil. The cutter blade operates suddenly. It is dangerous.

6. If the choke lever has been moved to the CLOSED position to start the engine, gradually move it to the OPEN position as the engine warms up.

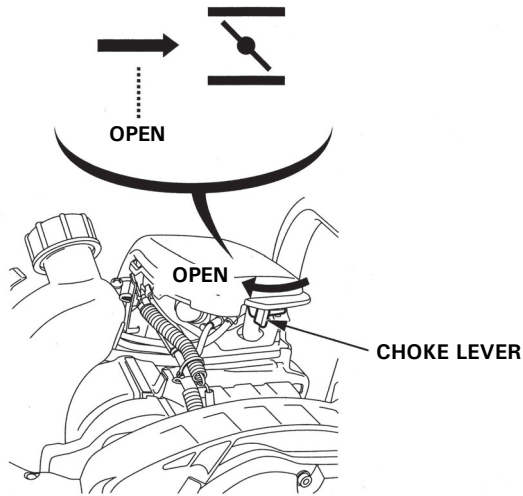

Hot Restart

If the engine is operated at higher ambient temperatures then turned off and allowed to sit for a short time, it may not restart on the first pull.

If necessary, use for following procedure:

IMPORTANT SAFETY PRECAUTION

Turn the engine switch to the OFF position before performing the following procedure. This will prevent the engine from starting and running at maximum speed when the throttle is in the full throttle position. If the engine starts, with the throttle in the full throttle position, the cutter blade can move at maximum speed. This may result in personal injury.

1. Turn the engine switch to the OFF position.
2. Move the choke lever to the OPEN position.
3. Hold the throttle lever in the full throttle position (FAST).
4. Pull the starter grip 3 to 5 times.
5. Follow the STARTING THE ENGINE procedure on page 34 and start the engine with the choke lever in the OPEN position.

Carburetor Modification for High Altitude Operation

At high altitude, the standard carburetor air-fuel mixture will be too rich. Performance will decrease, and fuel consumption will increase. A very rich mixture will also foul the spark plug and cause hard starting. Operation at an altitude that differs from that at which this engine was certified, for extended periods of time, may increase emissions.

High altitude performance can be improved by specific modifications to the carburetor. If you always operate your hedge trimmer at altitudes above 1,500 m (5,000 ft.), have your authorized Honda servicing dealer perform this carburetor modification. This engine, when operated at high altitude with the carburetor modifications for high altitude use, will meet each emission standard throughout its useful life.

Even with carburetor modification, engine horsepower will decrease about 3.5% for each 300 m (1,000 ft.) increase in altitude. The effect of altitude on horsepower will be greater than this if no carburetor modification is made.

CAUTION:

When the carburetor has been modified for high altitude operation, the air-fuel mixture will be too lean for low altitude use. Operation at altitudes below 1,500 m (5,000 ft.) with a modified carburetor may cause the engine to overheat and result in serious engine damage. For use at low altitudes, have your servicing dealer return the carburetor to original factory specifications.

7. TRIMMING OPERATION

Read and understand the safety instructions on pages 5 to 14 before operating the hedge trimmer.

If you notice any abnormal sound, smell, vibration, or other unusual signs, stop the engine immediately and consult your authorized Honda dealer.

Grip the handles with both your hands.

HHH25D: Use either of your hands for the front loop and use the other for the rear handle (throttle grip).

HHH25S: Use your right hand for the front handle and use your left hand for the rear handle (throttle grip).

CAUTION:

Do not use the hedge trimmer with one hand.

▲ WARNING

Do not operate the hedge trimmer if the operating cutter blade could reach your feet. Your feet can get injured if the operating cutter blade touches your feet.

NOTE:

This hedge trimmer is designed to trim the hedge, which is designed to cut off the branches of up to 8 mm (0.31 in) in diameter. Do not use the hedge trimmer to cut off the thicker branches beyond the above limit and do not use it to cut a hard material except a wood, either. It can damage the cutter blade and driving parts of the gear case and possibly shorten the service life of them.

Basic operation:

- Operate the hedge trimmer with care and continual movement to prevent the exhaust blowing onto one place of the hedge.
- When you grip the throttle lever with the engine running, the engine speed increases and the cutter blade starts to operate. Adjust the engine speed according to the size of a hedge.

CAUTION:

Increase the engine speed when you start to operate the hedge trimmer. Operating the trimmer at a low engine speed may cause engine failures.

-
- When you trim the upper part of a hedge, move the cutter blade to the right and left repeatedly.
 - To form the fine shape of a hedge, tilt the trimmer down slightly (up to 10°).

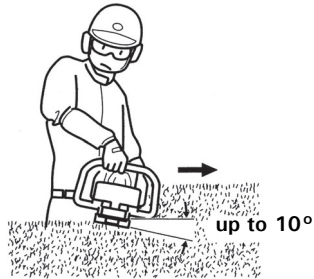

- Operate the trimmer with its cutter blade facing outside.

CAUTION:

Do not face the blade toward you during operation, and keep yourself away from the blade.



- To trim the side of a hedge, move the cutter blade from the bottom up.

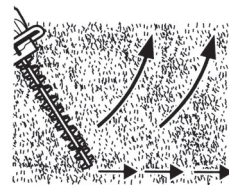

HHH25S:

- During operation, leave the trimmed branches, leaves, etc. on the grass plate.

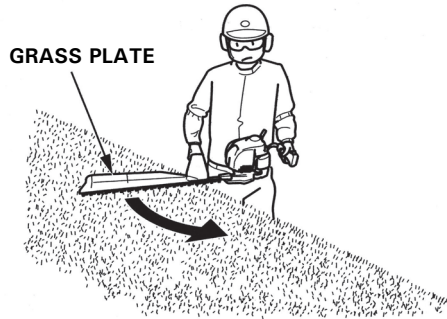

HHH25D:

- The rear handle can be turned to three positions (the CENTER position and 90° clockwise, and counterclockwise).
- Upper part: Turn the rear handle to the CENTER position when you trim the upper part of a hedge.
- Side part: When you use the cutter blade on the left side of your body, turn the rear handle 90° counterclockwise. When you use the right side of your body, turn the rear handle 90° clockwise (see page 42). When you trim the side of a hedge, face the cutter blade to the hedge and face the engine to your body.

CENTER position

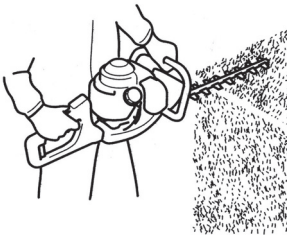

Turn the rear handle 90° clockwise.

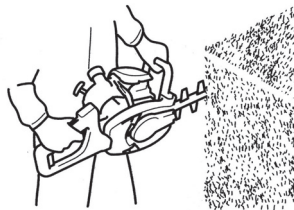

Turn the rear handle 90° counterclockwise.

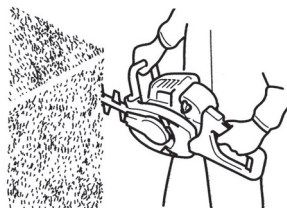

Turn the rear handle (HHH25D)

1. Be sure to stop the engine when you turn the rear handle.
 2. To turn the rear handle, release the throttle lever and the throttle lock lever, grip the rotation lever, and turn the handle clockwise or counterclockwise.
 3. Before operation, turn the rear handle until it clicks. Make sure that the rotation lever moves back.
- Do not operate the throttle lever, throttle lock lever and rotation lever at the same time. If you do, it may cause a failure.

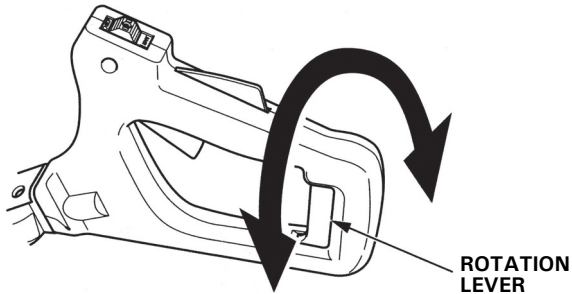

- Do not overreach.
- Keep the cutter blade below your knee height.
- Keep all part of your body away from the operating cutter blade and hot surfaces.

8. STOPPING THE ENGINE

1. Release the throttle lever and throttle lock lever.
2. Turn the engine switch to the OFF position.
Visually check that the cutter blade has stopped.
3. Before placing the hedge trimmer on the ground, make sure that the engine and the cutter blade have stopped.

CAUTION:

Even after the operating force stops, the cutter blade runs for a few seconds by inertia.

4. After operation, install the cutter blade cover into the cutter blade.

CAUTION:

Note that the cutting attachment keeps turning for a while by inertia after the engine is stopped.

HHH25D:

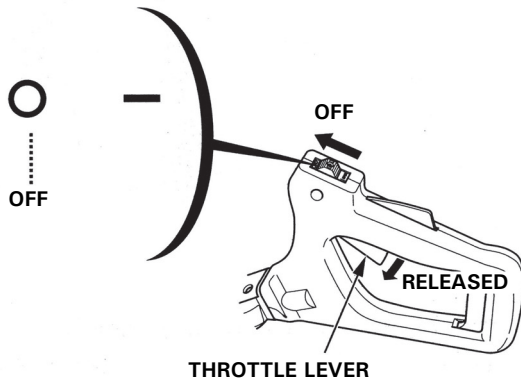

HHH25S:

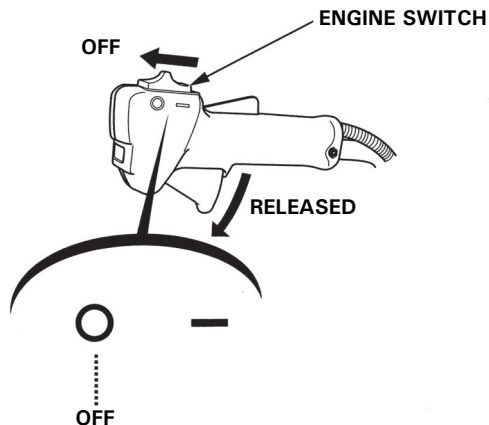

9. MAINTENANCE

⚠ WARNING

- Before performing any maintenance, place the hedge trimmer on a level surface, stop the engine and make sure that the engine switch is in the OFF position to be certain the engine will not start accidentally.
- The hedge trimmer should be serviced by an authorized Honda dealer unless the owner has proper tools and service data and feels he is mechanically qualified.

CAUTION:

Use only genuine Honda parts or their equivalent for maintenance or repair. Replacement parts which are not of equivalent quality may damage the trimmer.

Periodic inspection and adjustment of the Honda HHH25D/HHH25S are essential if high level performance is to be maintained. Regular maintenance will also help to extend service life. The required service intervals and the kind of maintenance to be performed are described in chart on the following page 45.

For longer service and efficiency, keep the cutter blade free of branches, leaves, etc. after every use.

Maintenance schedule

REGULAR SERVICE PERIOD (3) Perform at every indicated month or operating hour interval, whichever comes first.		Each use	First month or 10 hrs.	Every 3 months or 25 hrs.	Every 6 months or 50 hrs.	Every year or 100 hrs.	Every 2 years or 300 hrs.	Refer to page	
ITEM									
Engine oil	Check level	o						25	
	Change		o		o			47	
Air cleaner	Check	o						30	
	Clean			o(1)				49	
Spark plug	Check-adjust					o		50	
	Replace						o	50	
Throttle cable	Check	o						31	
Throttle lever	Check	o						31	
Rear handle (HHH25D)	Check	o						31	
Cutter blade	Check	o						32	
Cutter guard	Check	o						32	
Engine cooling fins	Check				o			54	
Nuts, bolts, fasteners	Check (Retighten if necessary)	o						33	
Spark arrester (Equipped type)						o		52	
Fuel tank	Clean					o		56	
Fuel filter	Check					o		55	
Clutch shoe and drum	Check				o(2)			—	
Gear case	Grease		Every year or 20 hrs. (2)						—
Idle speed	Check-adjust		o(2)		o(2)			—	
Valve Clearance	Check-adjust					o(2)		—	
Combustion chamber	Clean		After every 300 hrs. (2)						—
Fuel tubes	Check		Every 2 years (Replace if necessary) (2)						—
Oil tube	Check		Every 2 years (Replace if necessary) (2)						—

- (1) Service more frequently when used in dusty areas.
 (2) These items should be serviced by your servicing dealer.
 (3) Log hours of operation to determine proper maintenance intervals.

Tool kit

The tools supplied are necessary for performing some periodic maintenance, simple adjustments and repairs.

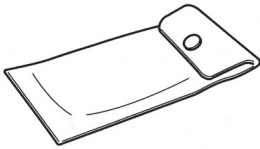

TOOL BAG

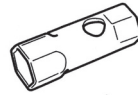

SPARK PLUG WRENCH



WRENCH



PLUG WRENCH HANDLE



HEXAGON WRENCH

1. Engine oil change

NOTE:

Drain the oil while the engine is still warm to assure rapid and complete draining.

1. Check the fuel tank cap is tightened securely.
2. Remove the oil filler cap and drain the oil into the oil container by tipping the hedge trimmer toward the oil filler neck.
3. Refill with the recommended oil (see page 26) and check the oil level (see page 25).
4. Install the oil filler cap.

ENGINE OIL CAPACITY: 0.08 L (0.08 US qt, 0.07 Imp qt)

Wash your hands with soap and water after handling used oil.

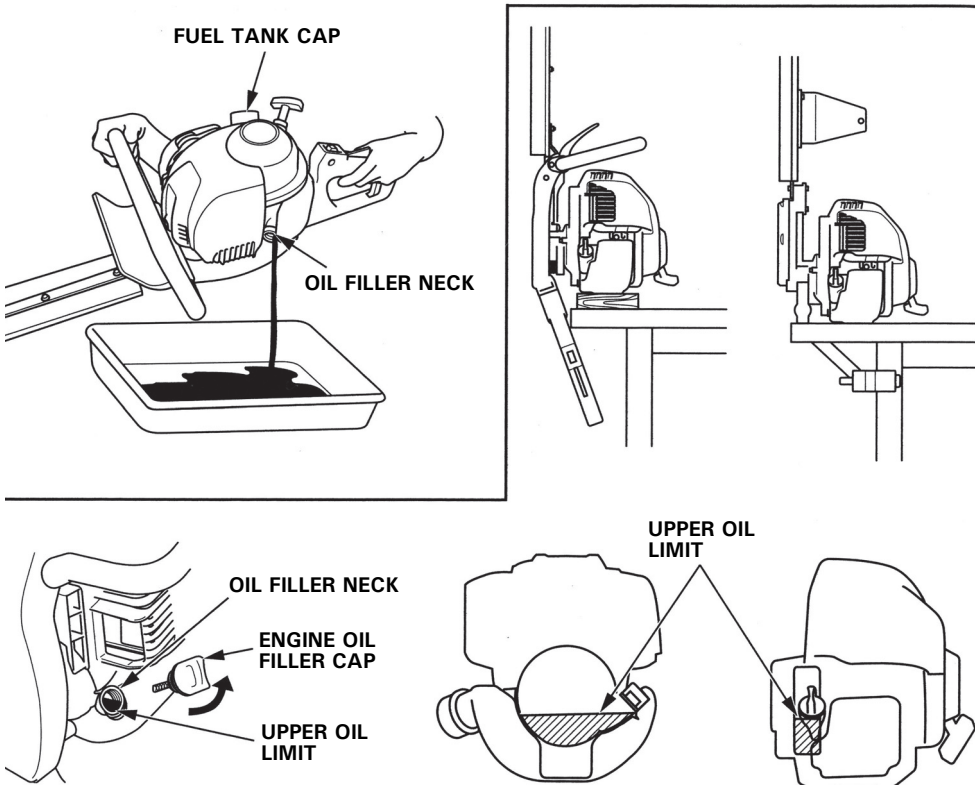

NOTE:

Please dispose of used motor oil in a manner that is compatible with the environment. We suggest you take it in a sealed container to your local service station for reclamation. Do not throw it in the trash or pour it on the ground or down a drain.

2. Air cleaner service

A dirty air cleaner will restrict air flow to the carburetor. To prevent carburetor malfunction, service the air cleaner regularly. Service more frequently when operating the hedge trimmer in extremely dusty areas.

⚠ WARNING

Never use gasoline or low flash point solvents for cleaning the air cleaner element. A fire or explosion could result.

CAUTION:

Never run the engine without the air cleaner. Rapid engine wear will result.

1. Move the choke lever to the CLOSED position (see page 23).
2. Remove the air cleaner cover by unhooking the right tab on the right of the air cleaner cover and its two left tabs.
3. Wash the element in a non-flammable or high flash point solvent and dry it thoroughly.
4. Soak the element in clean engine oil and squeeze out the excess oil.
5. Reinstall the air cleaner element.
6. Reinstall the air cleaner cover by inserting the left tabs, then insert the right tab.

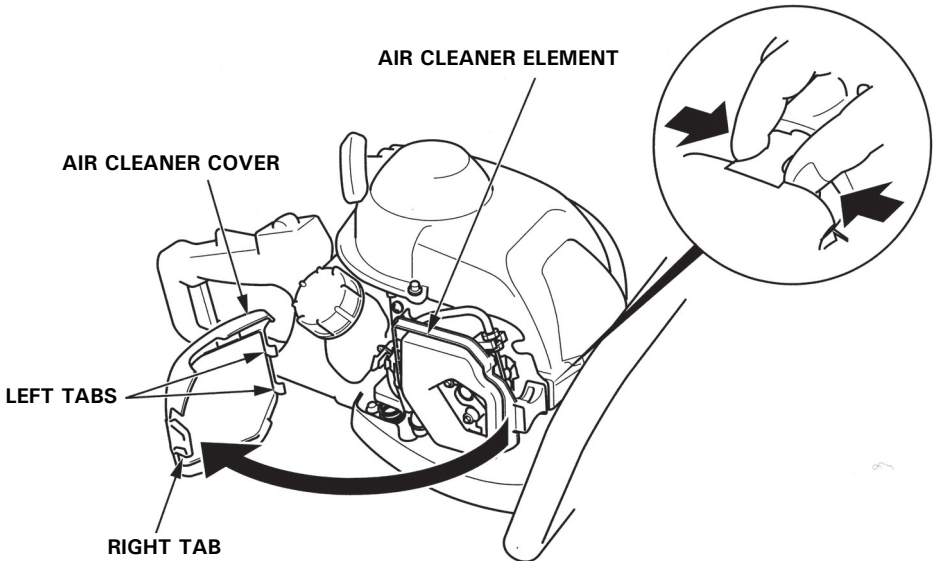

3. Spark plug service

Recommended spark plug: CMR5H (NGK)

To ensure proper engine operation, the spark plug must be properly gapped and free of deposits.

⚠ WARNING

If the engine has been running, the muffler will be very hot, be careful not to touch the muffler.

CAUTION:

Never use a spark plug of incorrect heat range.

1. Loosen the flange bolt with a hex wrench.
2. Remove the top cover, sliding it to the left.

Do not pull the starter grip and start the engine without the top cover. There are rotating and hot parts under the cover.

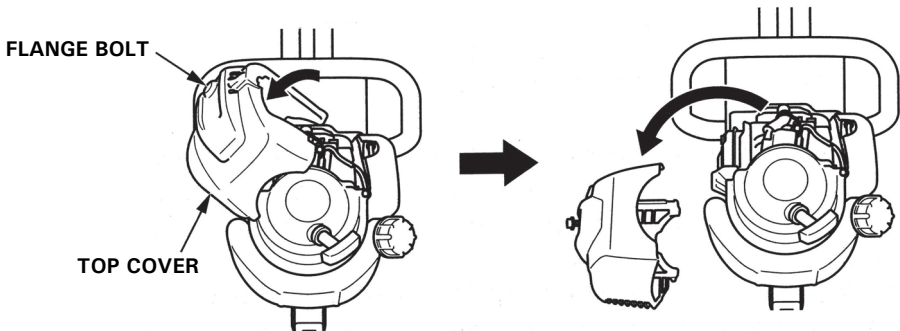

3. Remove any dirt from around the spark plug area.
4. Remove the spark plug cap and use the proper size spark plug wrench to remove the spark plug.

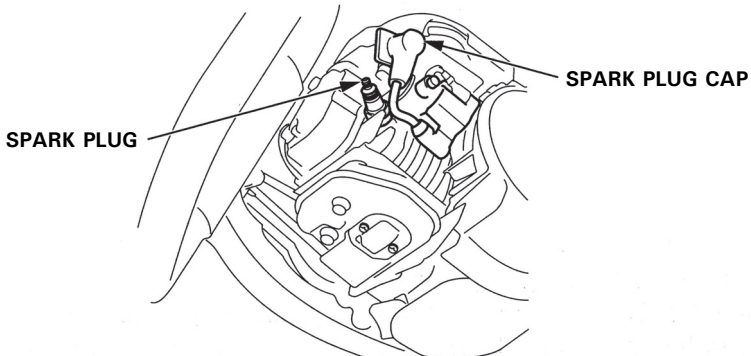

-
5. Visually inspect the spark plug. Discard the spark plug if there is apparent wear, or if the insulator is cracked or chipped. Clean the spark plug with a wire brush if it is to be reused.
 6. Measure the plug gap with a feeler gauge. Correct as necessary by bending the side electrode.

The gap should be:

0.6 – 0.7 mm (0.024 – 0.028 in)

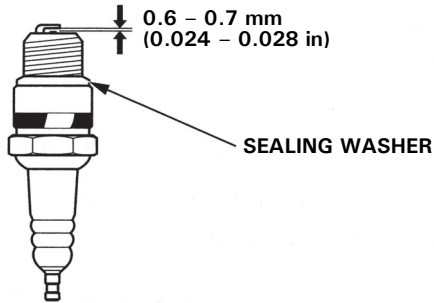

7. Check that the sealing washer is in good condition and thread the spark plug in by hand to prevent cross-threading.
8. After the spark plug is seated, tighten with a spark plug wrench to compress the washer.
When installing a new spark plug, tighten 1/2 turn after the spark plug seats to compress the washer. When reinstalling a used spark plug, tighten 1/8 – 1/4 turn after the spark plug seats to compress the washer.

CAUTION:

The spark plug must be securely tightened. An improperly tightened spark plug can become very hot and may damage the engine.

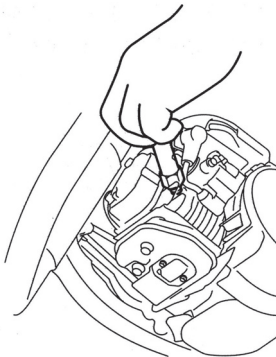

9. Attach the spark plug cap securely.
10. Install the top cover, and tighten the flange bolt securely.
Be careful not to tuck down the packing when you install the top cover.

4. Spark arrester service (Equipped type)

⚠ WARNING

If the engine has been running, the muffler will be very hot, be careful not to touch the muffler.

The spark arrester must be serviced every 100 hours to keep it functioning as designed.

1. Loosen the flange bolt with a hex wrench (see page 50).
2. Remove the top cover, sliding it to the left (see page 50).
Do not pull the starter grip and start the engine without the top cover.
There are rotating and hot parts under the cover.
3. Remove the 4 mm screws from the spark arrester, and remove the spark arrester from the muffler.

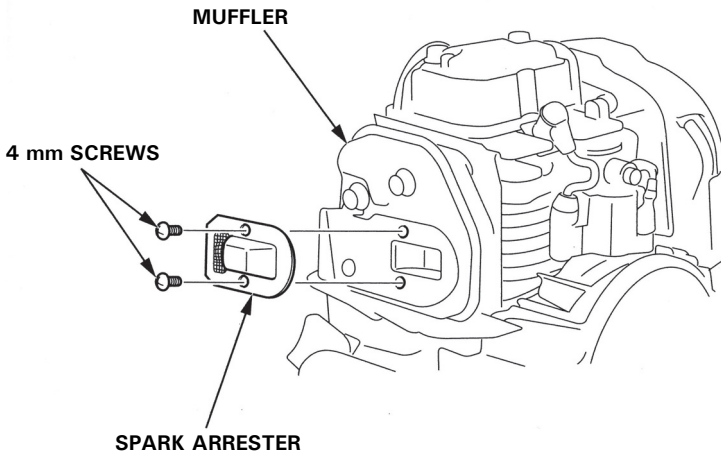

-
4. Use a brush to remove carbon deposits from the spark arrester screen.
Be careful to avoid damaging the screen.
The spark arrester must be free of breaks and holes. If it is damaged or fouled excessively, have it serviced by your Honda dealer.
 5. Install the spark arrester in the reverse order of disassembly.
 6. Install the top cover, and tighten the flange bolt securely.
Be careful not to tuck down the packing when you install the top cover.

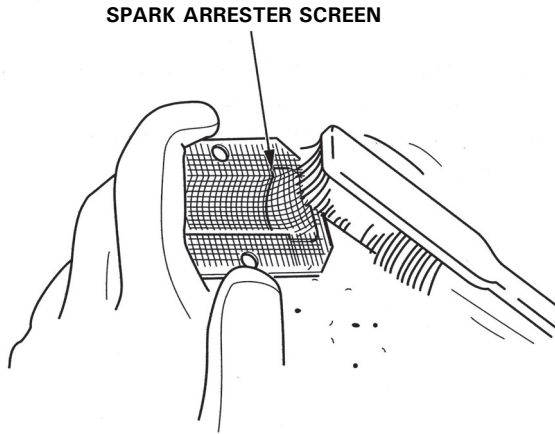

5.Engine cooling fins inspection

Inspect the cooling fins visually through the top cover. If there are dry grass, leaves and mud clogged, consult your authorized Honda power equipment dealer for cleaning it.

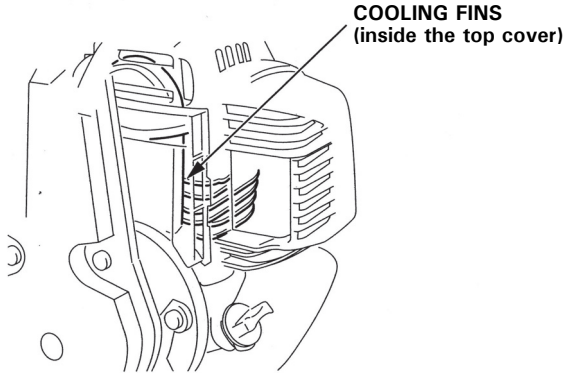

6. Fuel filter service

⚠ WARNING

Gasoline is extremely flammable and is explosive under certain conditions. Do not smoke or allow flames or sparks in the area.

1. Check the engine oil filler cap is tightened securely.
2. Remove the fuel tank cap and drain the fuel into an approved gasoline container by inclining the hedge trimmer toward the fuel filler neck.

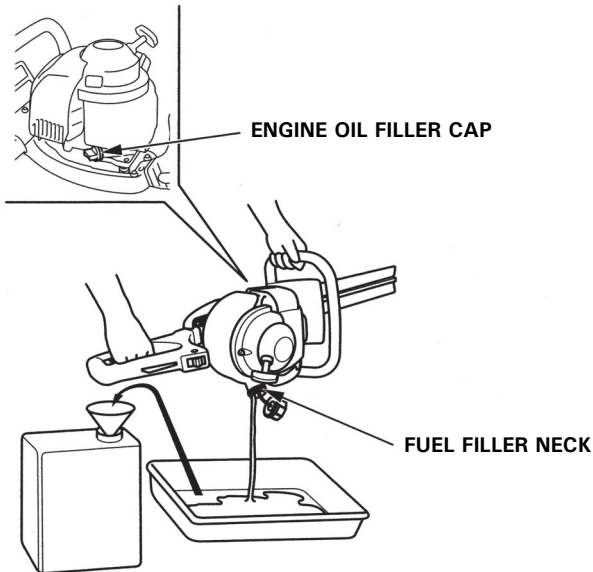

3. Pull out the fuel filter with the mechanic's wire from the fuel filler neck gently.
4. Check the fuel filter of its dirt. If the fuel filter is dirty, wash it gently with non-flammable or high flash point solvent. If the fuel filter is excessively dirty, replace it.

< For Europe type >

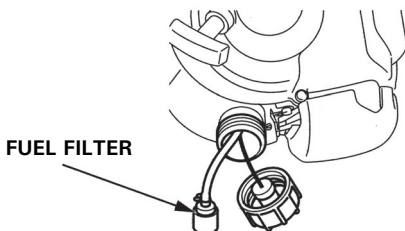

< Except for Europe type >

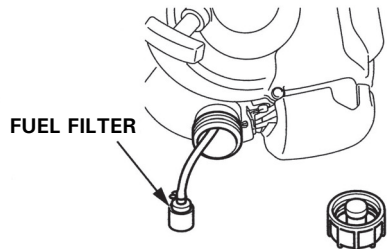

5. Return the fuel filter into the fuel tank and tighten the fuel tank cap securely.

7. Fuel tank cleaning

⚠ WARNING

Gasoline is extremely flammable and is explosive under certain conditions. Do not smoke or allow flames or sparks in the area.

1. Check the engine oil filler cap is tightened securely.
2. Remove the fuel tank cap and drain the fuel into an approved gasoline container by inclining the hedge trimmer toward the fuel filler neck.

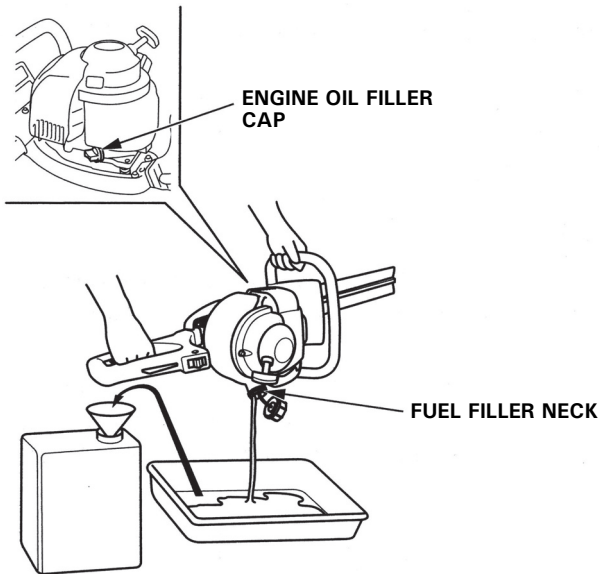

3. Pull out the fuel filter with the mechanic's wire from the fuel filler neck gently.
4. Remove water and dirt stood in the fuel tank by rinsing the inside of the fuel tank with non-flammable or high flash point solvent.

< For Europe type >

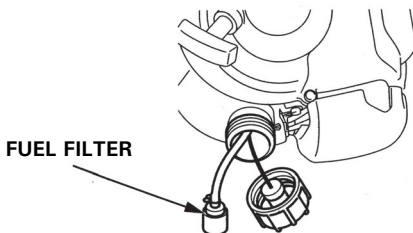

< Except for Europe type >

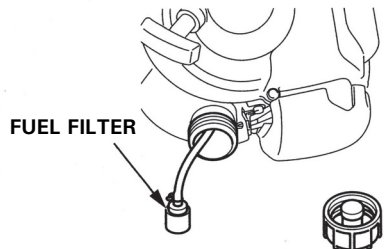

5. Return the fuel filter into the fuel tank and tighten the fuel tank cap securely.

Proper storage preparation is essential for keeping your hedge trimmer trouble free and looking good. The following steps will help to keep rust and corrosion from impairing your hedge trimmer.

CAUTION:

- If the hedge trimmer has been running, the engine will be very hot; allow it to cool before proceeding.
- Place the hedge trimmer on a level surface and remove the spark plug cap to be certain the engine will not start accidentally.

1. Clean all exterior surfaces, touch up any damaged paint, and coat other areas that may rust with a light film of oil.
2. Drain the fuel....

▲ WARNING

Gasoline is extremely flammable and explosive under certain conditions. Do not smoke or allow flames or sparks in the area.

- a. Be sure that the engine oil filler cap is tightened securely.
- b. Remove the fuel tank cap and drain the fuel into an approved gasoline container by tipping the hedge trimmer toward the fuel filler neck.

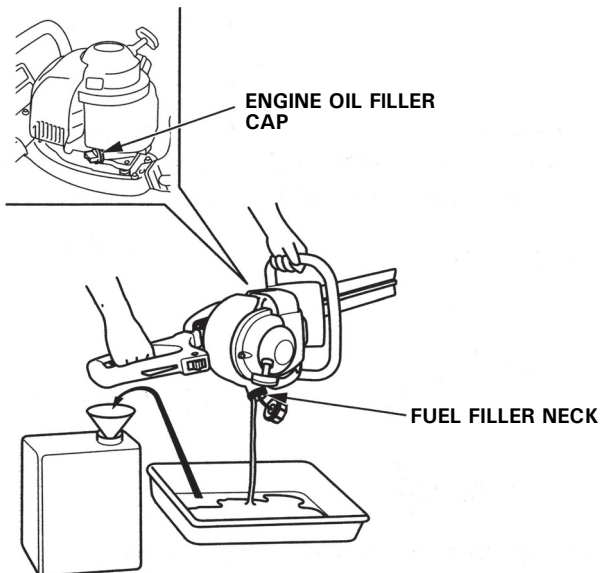

-
- c. Press the priming pump several times until all fuel left in the fuel return tube (transparent tube) is returned into the fuel tank.

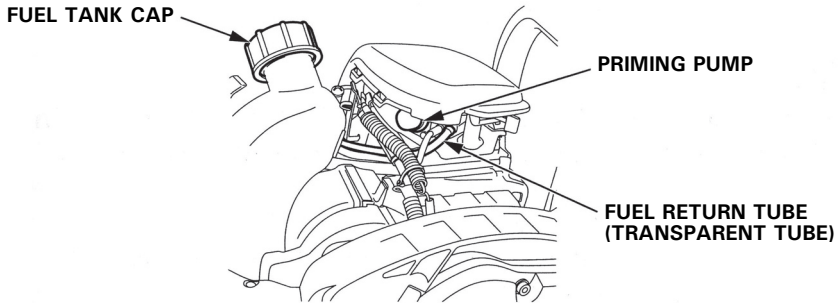

- d. Tip the hedge trimmer toward the fuel filler neck again to drain the fuel left in the fuel tank into the container.
- e. Tighten the fuel tank cap securely after draining the fuel completely.

3. Change the engine oil (see page 47).
4. Clean the air cleaner (see page 49).
5. Loosen the flange bolt with a hex wrench, then remove the top cover (see page 50).
6. Remove the spark plug (see page 50).
7. Apply a couple of drops of clean engine oil into the cylinder.
8. Install the top cover temporarily.
9. Pull the starter grip several times to distribute the oil in the cylinder.
10. Remove the top cover, then reinstall the spark plug.
11. Install the top cover, and tighten the flange bolt securely.
12. Pull the starter grip slowly until resistance is felt.
13. Apply oil to the cutter blade.
14. Install the cover into the cutter blade.
15. Keep the hedge trimmer out of reach of children, and keep it free from moisture and dust.
16. Cover the hedge trimmer to keep out dust.

When the engine will not start:

1. Is the engine switch in the ON position?
2. Is there fuel in the fuel tank (see page 27)?

⚠ WARNING

Gasoline is extremely flammable and explosive under certain conditions. Do not smoke or allow flames or sparks in the area.

3. Is gasoline reaching the carburetor?
To check, press the priming pump several times (see page 35).
4. Is the spark plug in good condition?
Remove and inspect the spark plug. Clean, readjust gap and dry the spark plug. Replace it if necessary (see page 50).
5. If the engine still does not start, take the hedge trimmer to an authorized Honda dealer.

When an abnormal vibration occurs during operation, immediately turn off the engine and check the cutter blade is properly installed and tightened securely, and inspect it for wear, crack or any other damage (see page 32).

12. SPECIFICATIONS

Model	HHH25D
Power products description code	UTBJ

Frame

Type	60ET, 60UT	75ET, 75UT
Blade type	Dual blade	
Overall length	1,080 mm (42.5 in)	1,220 mm (48.0 in)
Overall width	312 mm (12.3 in)	
Overall height	259 mm (10.2 in)	
Dry mass [weight]	6.3 kg (13.9 lbs)	6.6 kg (14.6 lbs)
Clutch type	Centrifugal clutch	
Blade length	580 mm (22.8 in)	720 mm (28.3 in)

Noise and Vibration

Type		60ET	60UT	75ET	75UT
Sound pressure level at operator's ears EN774: 1996/A3: 2001		92 dB (A)	—	90 dB (A)	—
Uncertainty		3 dB (A)	—	2 dB (A)	—
Measured sound power level (2000/14/EC, 2005/88/EC)		101 dB (A)	—	102 dB (A)	—
Uncertainty		3 dB (A)	—	2 dB (A)	—
Guaranteed sound power level (2000/14/EC, 2005/88/EC)		104 dB (A)	—	104 dB (A)	—
Sound pressure level Australia New South Wales standard		—	82 dB (A)	—	82 dB (A)
Vibration level at hand arm (EN774: 1996/A3: 2001)	Fr.	5.2 m/s ²		5.2 m/s ²	
	Rr.	6.9 m/s ²		6.9 m/s ²	
Uncertainty (EN12096: 1997 Annex D)	Fr.	2.1 m/s ²		2.1 m/s ²	
	Rr.	2.8 m/s ²		2.8 m/s ²	

Specifications are subject to change without notice.

Engine

Engine model	GX25T
Engine description code	GCA LT
Engine type	4-stroke, overhead camshaft, 1 cylinder
Displacement	25.0 cm ³ (1.53 cu-in)
Bore × Stroke	35.0 × 26.0 mm (1.38 × 1.02 in)
Engine Net Power (in accordance with SAE J1349*)	0.72 kW (1.0 PS)/7,000 rpm
Engine Max. Net Torque (in accordance with SAE J1349*)	1.0 N·m (0.10 kgf·m, 0.74 lbf·ft)/5,000 rpm
Cooling system	Forced air
Ignition system	Transistorized magneto
Oil capacity	0.08 L (0.08 US qt, 0.07 Imp qt)
Fuel tank capacity	0.45 L (0.119 US gal, 0.099 Imp gal)
Spark plug	NGK: CMR5H

*: The power rating of the engine indicated in this document is the net power output tested on a production engine for the engine model and measured in accordance with SAE J1349 at 7,000 rpm (Engine Net Power) and at 5,000 rpm (Engine Net Torque). Mass production engines may vary from this value.

Actual power output for the engine installed in the final machine will vary depending on numerous factors, including the operating speed of the engine in application, environmental conditions, maintenance, and other variables.

Tune up

ITEM	SPECIFICATION	MAINTENANCE
Spark plug gap	0.6 – 0.7 mm (0.024 – 0.028 in)	Refer to page: 50
Valve clearance (cold)	IN: 0.08 ± 0.02 mm EX: 0.11 ± 0.02 mm	See your authorized Honda dealer
Other specifications	No other adjustment needed.	

Specifications are subject to change without notice.

Model	HHH25S
Power products description code	UTAJ

Frame

Type	75ET
Blade type	Single blade
Overall length	1,125 mm (44.3 in)
Overall width	310 mm (12.2 in)
Overall height	259 mm (10.2 in)
Dry mass [weight]	5.8 kg (12.8 lbs)
Clutch type	Centrifugal clutch
Blade length	720 mm (28.3 in)

Noise and Vibration

Type	75ET	
Sound pressure level at operator's ears EN774: 1996/A3: 2001	90 dB (A)	
Uncertainty	3 dB (A)	
Measured sound power level (2000/14/EC, 2005/88/EC)	101 dB (A)	
Uncertainty	3 dB (A)	
Guaranteed sound power level (2000/14/EC, 2005/88/EC)	104 dB (A)	
Sound pressure level Australia New South Wales standard	—	
Vibration level at hand arm (EN774: 1996/A3: 2001)	Fr.	12.3 m/s ²
	Rr.	5.4 m/s ²
Uncertainty (EN12096: 1997 Annex D)	Fr.	4.9 m/s ²
	Rr.	2.2 m/s ²

Specifications are subject to change without notice.

Engine

Engine model	GX25T
Engine description code	GCA LT
Engine type	4-stroke, overhead camshaft, 1 cylinder
Displacement	25.0 cm ³ (1.53 cu-in)
Bore × Stroke	35.0 × 26.0 mm (1.38 × 1.02 in)
Engine Net Power (in accordance with SAE J1349*)	0.72 kW (1.0 PS)/7,000 rpm
Engine Max. Net Torque (in accordance with SAE J1349*)	1.0 N·m (0.10 kgf·m, 0.74 lbf·ft)/5,000 rpm
Cooling system	Forced air
Ignition system	Transistorized magneto
Oil capacity	0.08 L (0.08 US qt, 0.07 Imp qt)
Fuel tank capacity	0.45 L (0.119 US gal, 0.099 Imp gal)
Spark plug	NGK: CMR5H

*: The power rating of the engine indicated in this document is the net power output tested on a production engine for the engine model and measured in accordance with SAE J1349 at 7,000 rpm (Engine Net Power) and at 5,000 rpm (Engine Net Torque). Mass production engines may vary from this value.

Actual power output for the engine installed in the final machine will vary depending on numerous factors, including the operating speed of the engine in application, environmental conditions, maintenance, and other variables.

Tune up

ITEM	SPECIFICATION	MAINTENANCE
Spark plug gap	0.6 – 0.7 mm (0.024 – 0.028 in)	Refer to page: 50
Valve clearance (cold)	IN: 0.08 ± 0.02 mm EX: 0.11 ± 0.02 mm	See your authorized Honda dealer
Other specifications	No other adjustment needed.	

Specifications are subject to change without notice.

