

INTRODUCTION

Congratulations on your selection of a Honda water pump. We are certain you will be pleased with your purchase of one of the finest water pumps on the market.

We want to help you get the best results from your new water pump and to operate it safely. This manual contains the information on how to do that; please read it carefully.

As you read this manual, you will find information preceded by a **NOTICE** symbol. That information is intended to help you avoid damage to your water pump, other property, or the environment.

We suggest you read the warranty policy to fully understand its coverage and your responsibilities of ownership.

When your water pump needs scheduled maintenance, keep in mind that your Honda servicing dealer is specially trained in servicing Honda water pumps. Your Honda servicing dealer is dedicated to your satisfaction and will be pleased to answer your questions and concerns.

Best Wishes,
Honda Motor Co., Ltd.

INTRODUCTION

A FEW WORDS ABOUT SAFETY

Your safety and the safety of others are very important. And using this water pump safely is an important responsibility.

To help you make informed decisions about safety, we have provided operating procedures and other information on labels and in this manual. This information alerts you to potential hazards that could hurt you or others.

Of course, it is not practical or possible to warn you about all the hazards associated with operating or maintaining a water pump. You must use your own good judgment.

You will find important safety information in a variety of forms, including:

- **Safety Labels** — on the pump.
- **Safety Messages** — preceded by a safety alert symbol  and one of three signal words, DANGER, WARNING, or CAUTION.

These signal words mean:

 **DANGER**

You **WILL** be **KILLED** or **SERIOUSLY HURT** if you don't follow instructions.

 **WARNING**

You **CAN** be **KILLED** or **SERIOUSLY HURT** if you don't follow instructions.

 **CAUTION**

You **CAN** be **HURT** if you don't follow instructions.

- **Safety Headings** — such as *IMPORTANT SAFETY INFORMATION*.
- **Safety Section** — such as *PUMP SAFETY*.
- **Instructions** — how to use this pump correctly and safely.

This entire book is filled with important safety information — please read it carefully.

CONTENTS

| | |
|---|-----------|
| PUMP SAFETY | 5 |
| IMPORTANT SAFETY INFORMATION | 5 |
| SAFETY LABEL LOCATIONS..... | 7 |
| CONTROLS | 8 |
| COMPONENT & CONTROL LOCATIONS..... | 8 |
| CONTROLS | 9 |
| Ignition Switch..... | 9 |
| Choke Lever | 9 |
| Throttle Lever | 10 |
| Recoil Starter Grip | 10 |
| BEFORE OPERATION | 11 |
| ARE YOU READY TO GET STARTED? | 11 |
| IS YOUR PUMP READY TO GO?..... | 11 |
| Check the General Condition of the Pump | 12 |
| Check the Suction and Discharge Hoses..... | 12 |
| Check the Engine | 12 |
| OPERATION | 13 |
| SAFE OPERATING PRECAUTIONS | 13 |
| PUMP PLACEMENT | 15 |
| SUCTION HOSE INSTALLATION | 16 |
| DISCHARGE HOSE INSTALLATION..... | 17 |
| PRIMING THE PUMP..... | 18 |
| STARTING THE ENGINE | 20 |
| SETTING ENGINE SPEED..... | 23 |
| STOPPING THE ENGINE | 24 |
| SERVICING YOUR PUMP | 25 |
| THE IMPORTANCE OF MAINTENANCE | 25 |
| MAINTENANCE SAFETY | 26 |
| MAINTENANCE SCHEDULE | 27 |
| REFUELING..... | 28 |
| FUEL RECOMMENDATIONS..... | 29 |
| ENGINE OIL LEVEL CHECK | 30 |
| ENGINE OIL CHANGE | 31 |
| ENGINE OIL RECOMMENDATIONS | 33 |

CONTENTS

| | |
|--|-----------|
| SERVICING YOUR PUMP (continued) | |
| AIR CLEANER SERVICE..... | 34 |
| AIR FILTER CLEANING..... | 35 |
| SPARK PLUG SERVICE..... | 36 |
| COOLING FIN INSPECTION..... | 39 |
| FUEL FILTER INSPECTION and FUEL TANK CLEANING..... | 40 |
| FUEL TUBE INSPECTION..... | 42 |
| SPARK ARRESTER SERVICE..... | 43 |
| STORAGE..... | 45 |
| STORAGE PREPARATION..... | 45 |
| Cleaning..... | 45 |
| Fuel..... | 47 |
| Engine Oil..... | 49 |
| Engine Cylinder..... | 49 |
| STORAGE PRECAUTIONS..... | 50 |
| REMOVAL FROM STORAGE..... | 50 |
| TRANSPORTING..... | 51 |
| TAKING CARE OF UNEXPECTED PROBLEMS..... | 52 |
| ENGINE..... | 52 |
| Engine Will Not Start..... | 52 |
| Engine Lacks Power..... | 52 |
| PUMP..... | 53 |
| No Pump Output..... | 53 |
| Low Pump Output..... | 53 |
| TECHNICAL INFORMATION..... | 54 |
| Serial Number Locations..... | 54 |
| Carburetor Modification for High Altitude Operation..... | 55 |
| Specifications..... | 56 |
| CONSUMER INFORMATION..... | 57 |
| Australia Distributor Information..... | 57 |

PUMP SAFETY

IMPORTANT SAFETY INFORMATION

The Honda WX10T pump is designed to pump only fresh water that is not intended for human consumption, and other uses can result in injury to the operator or damage to the pump and other property.

Most injuries or property damage can be prevented if you follow all instructions in this manual and on the pump. The most common hazards are discussed below, along with the best way to protect yourself and others.

Operator Responsibility

It is the operator's responsibility to provide the necessary safeguards to protect people and property. Know how to stop the pump quickly in case of emergency. If you leave the pump for any reason, always turn the engine off. Understand the use of all controls and connections.

Be sure that anyone who operates the pump receives proper instruction. Do not let children operate the pump. Keep children and pets away from the area of operation.

Pump Operation

Pump only water that is not intended for human consumption. Pumping flammable liquids, such as gasoline or fuel oils, can result in a fire or explosion, causing serious injury. Pumping sea water, beverages, acids, chemical solutions, or any other liquid that promotes corrosion can damage the pump.

Refuel With Care

Gasoline is extremely flammable, and gasoline vapor can explode. Do not refuel during operation.

Allow the engine to cool if it has been in operation.

Refuel only outdoors in a well-ventilated area and on a level surface.

Never smoke near gasoline, and keep other flames and sparks away.

Do not overfill the fuel tank.

Make sure that any spilled fuel has been wiped up before starting the engine.

Always store gasoline in an approved container.

PUMP SAFETY

Hot Exhaust

The muffler becomes very hot during operation and remains hot for a while after stopping the engine. Be careful not to touch the muffler while it is hot. Let the engine cool before transporting the pump or storing it indoors.

To prevent fire hazards, keep the pump at least 1 meter away from building walls and other equipment during operation. Do not place flammable objects close to the engine.

Carbon Monoxide Hazard

Your water pump's exhaust contains poisonous carbon monoxide gas, which you cannot see or smell.

Breathing carbon monoxide can KILL YOU IN MINUTES.

For your safety:

- Do not start or operate the engine in any closed or partially enclosed area, such as a garage.
- Never run the water pump in a closed or even partially closed area where people or pets may be present.
- Never operate the water pump near open doors, windows, or vents.
- Get fresh air and seek medical attention immediately if you suspect you have inhaled carbon monoxide.

Early symptoms of carbon monoxide exposure include headache, fatigue, shortness of breath, nausea, and dizziness. Continued exposure to carbon monoxide can cause loss of muscular coordination, loss of consciousness, and then death.

SAFETY LABEL LOCATIONS

The labels shown here contain important safety information. Please read them carefully. These labels are considered permanent parts of your pump. If a label comes off or becomes hard to read, contact an authorized Honda servicing dealer for a replacement.

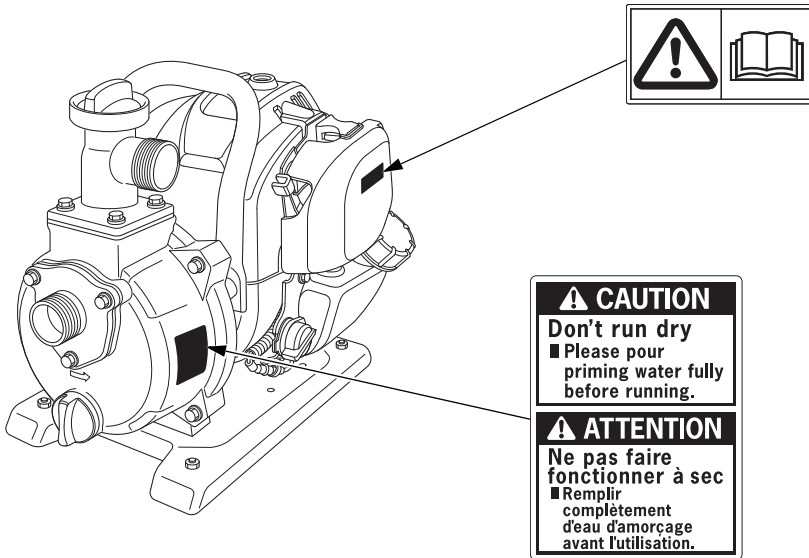

- **Honda water pump is designed to give safe and dependable service if operated according to instructions.**

Read and understand the Owner's Manual before operating the water pump. Failure to do so could result in personal injury or equipment damage.

CONTROLS

COMPONENT & CONTROL LOCATIONS

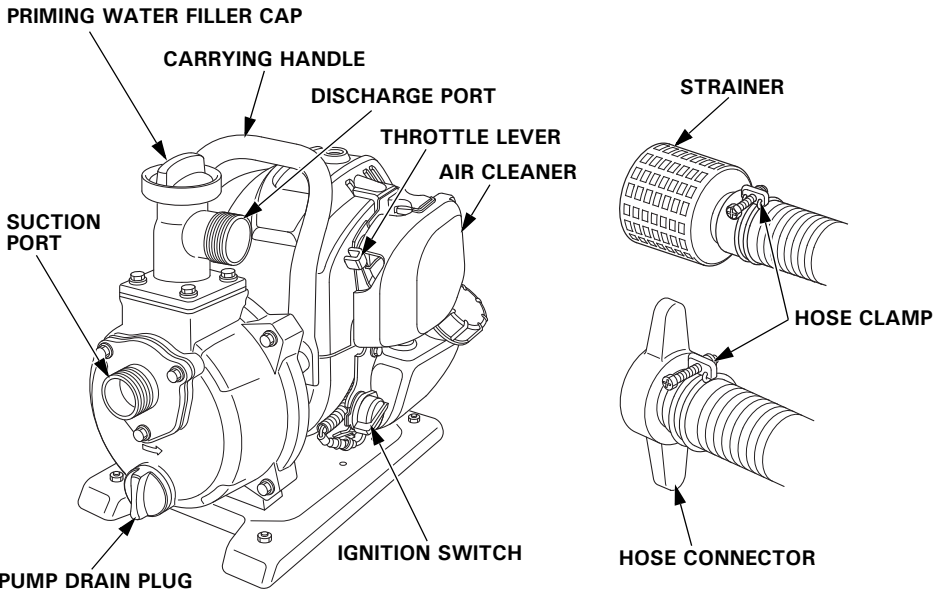
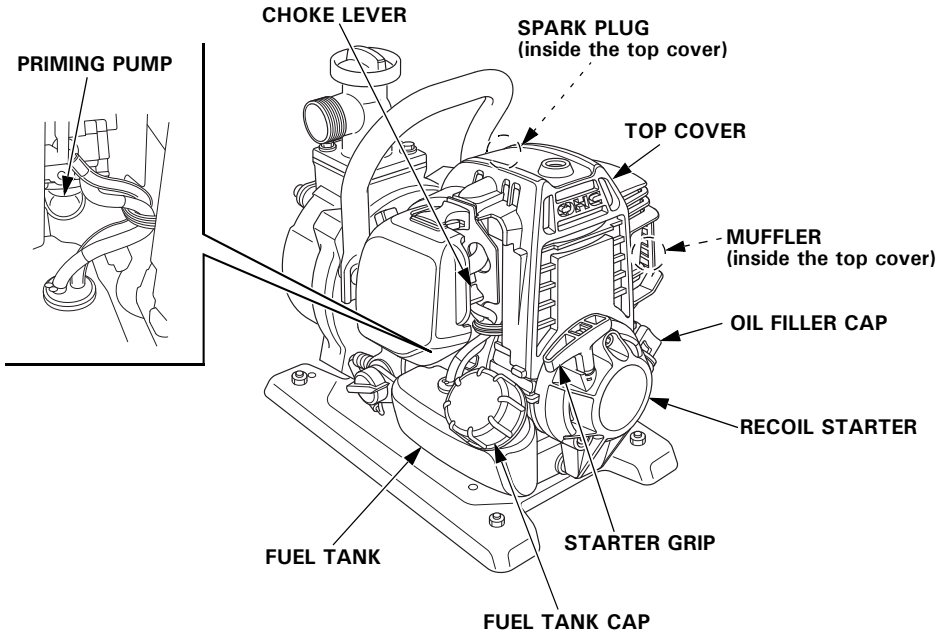

CONTROLS

Ignition Switch

The ignition switch controls the ignition system.

The ignition switch must be in the ON position for the engine to run.

Turning the ignition switch to the OFF position stops the engine.

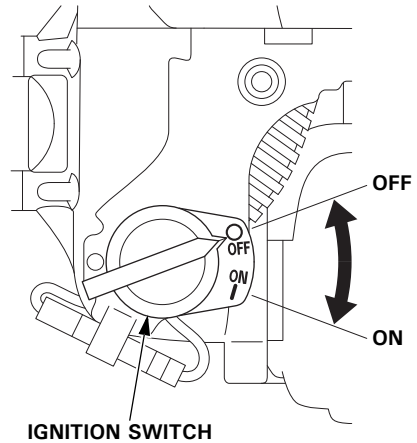

Choke Lever

The choke lever opens and closes the choke valve in the carburetor.

The CLOSED position enriches the fuel mixture for starting a cold engine.

The OPEN position provides the correct fuel mixture for operation after starting, and for restarting a warm engine.

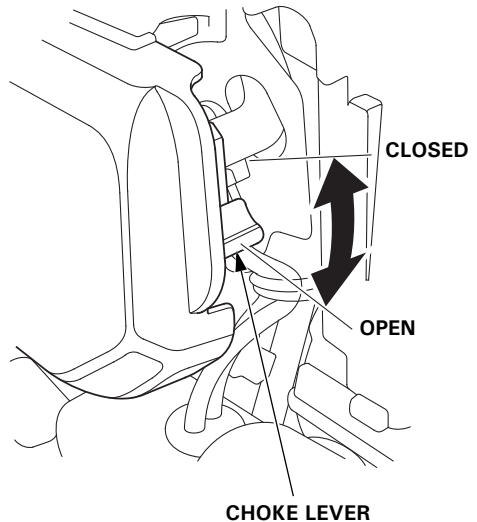

CONTROLS

Throttle Lever

The throttle lever controls engine speed.

Moving the throttle lever in the directions shown makes the engine run faster or slower.

Pump output is controlled by adjusting the throttle lever. At the FAST position, the pump will deliver the highest output volume. Moving the throttle lever toward the SLOW position will decrease the output volume of the pump.

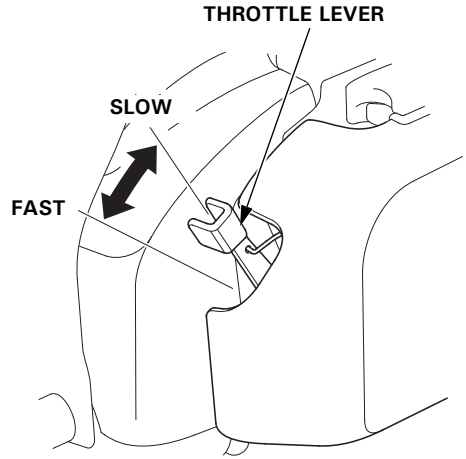

Recoil Starter Grip

Pulling the starter grip operates the recoil starter to crank the engine for starting.

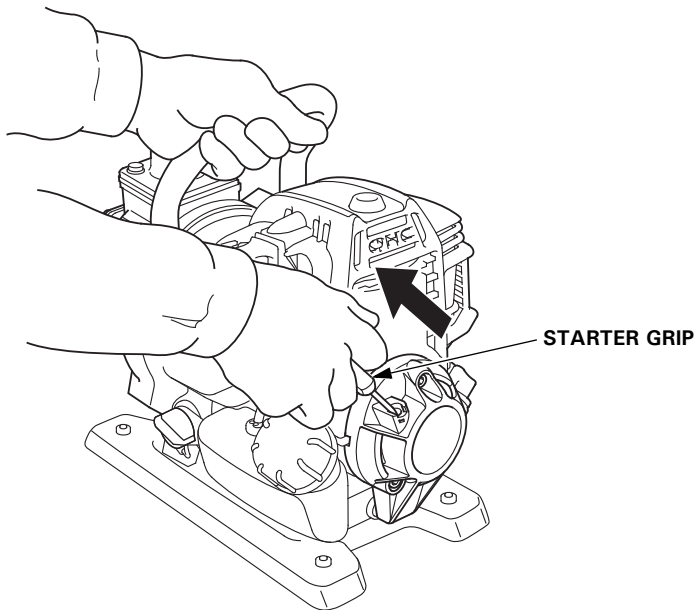

BEFORE OPERATION

ARE YOU READY TO GET STARTED?

Your safety is your responsibility. A little time spent in preparation will significantly reduce your risk of injury.

Knowledge

Read and understand this manual. Know what the controls do and how to operate them.

Familiarize yourself with the pump and its operation before you begin pumping. Know what to do in case of emergencies.

Be sure of what you are pumping. This pump is designed to pump only fresh water that is not intended for human consumption.

IS YOUR PUMP READY TO GO?

For your safety, and to maximize the service life of your equipment, it is very important to take a few moments before you operate the pump to check its condition. Be sure to take care of any problem you find, or have your servicing dealer correct it, before you operate the pump.

⚠ WARNING

Improperly maintaining this pump, or failing to correct a problem before operation, could cause a malfunction in which you could be seriously injured.

Always perform a pre-operation inspection before each operation, and correct any problem.

To prevent fire hazards, keep the pump at least 1 meter away from building walls and other equipment during operation. Do not place flammable objects close to the engine.

Before beginning your pre-operation checks, be sure the pump is on a level surface and the ignition switch is in the OFF position.

BEFORE OPERATION

Check the General Condition of the Pump

- Before each use, look around and underneath the engine for signs of oil or gasoline leaks.
- Remove any excessive dirt or debris, especially around the engine muffler, and recoil starter.
- Look for signs of damage.
- Check that all nuts, bolts, screws, hose connectors and clamps are tightened.

Check the Suction and Discharge Hoses

- Check the general condition of the hoses. Be sure the hoses are in serviceable condition before connecting them to the pump. Remember that the suction hose must be reinforced construction to prevent hose collapse.
- Check that the hose coupling packings in the suction hose and discharge hose connectors are in good condition (see pages 16 and 17).
- Check that the hose connectors and clamps are securely installed (see pages 16 and 17).
- Check that the strainer is in good condition and is installed on the suction hose (see page 16).

Check the Engine

- Check the engine oil level (see page 30). Running the engine with a low oil level can cause engine damage.
- Check the air filter (see page 34). A dirty air filter will restrict air flow to the carburetor, reducing engine and pump performance.
- Check the fuel level (see page 28). Starting with a full tank will help to eliminate or reduce operating interruptions for refueling.

OPERATION

SAFE OPERATING PRECAUTIONS

To safely realize the full potential of this pump, you need a complete understanding of its operation and a certain amount of practice with its controls.

Before operating the pump for the first time, please review the *IMPORTANT SAFETY INFORMATION* on page 5 and the chapter titled *BEFORE OPERATION*.

For your safety, avoid starting or operating the engine in an enclosed area, such as a garage. Your engine's exhaust contains poisonous carbon monoxide gas that can collect rapidly in an enclosed area and cause illness or death.

⚠ WARNING

Exhaust contains poisonous carbon monoxide gas that can build up to dangerous levels in closed areas. Breathing carbon monoxide can cause unconsciousness or death.

Never run the engine in a closed, or even partly closed area where people may be present.

Pump only fresh water that is not intended for human consumption. Pumping flammable liquids, such as gasoline or fuel oils, can result in a fire or explosion, causing serious injury. Pumping sea water, beverages, acids, chemical solutions, or any other liquid that promotes corrosion can damage the pump.

OPERATION

NOTICE

Do not allow the pump to tip over or fall in its side during use. If the pump is not positioned upright or if there is not enough space around the pump, cooling air can become restricted or the engine exhaust may be obstructed, causing engine damage.

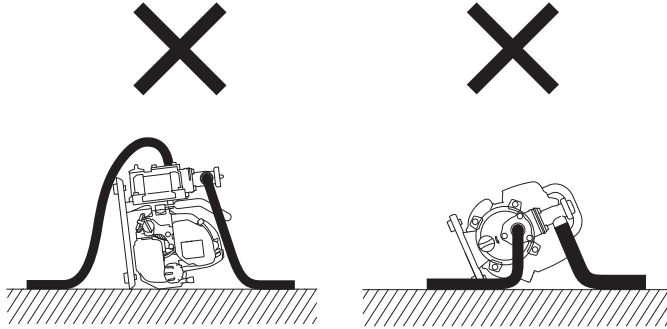

PUMP PLACEMENT

Always position the pump in an upright position on a firm level surface at least 1 meter away from any walls or other equipment.

For best pump performance, place the pump near the water level, and use hoses that are no longer than necessary. That will enable the pump to produce the greatest output with the least self-priming time.

As *head* (pumping height) increases, pump output decreases. Maximum head specifications are shown in the tables on page 56. The length, type, and size of the suction and discharge hoses can also significantly affect pump output.

Discharge head capability is always greater than suction head capability, so it is important for suction head to be the shorter part of total head.

The maximum available suction head will vary based on the operating conditions. However, the suction head can never exceed 8 meters and should always be kept as low as possible.

Minimizing suction head (placing the pump near the water level) is also very important for reducing self-priming time. Self-priming time is the time it takes the pump to bring water the distance of the suction head during initial operation.

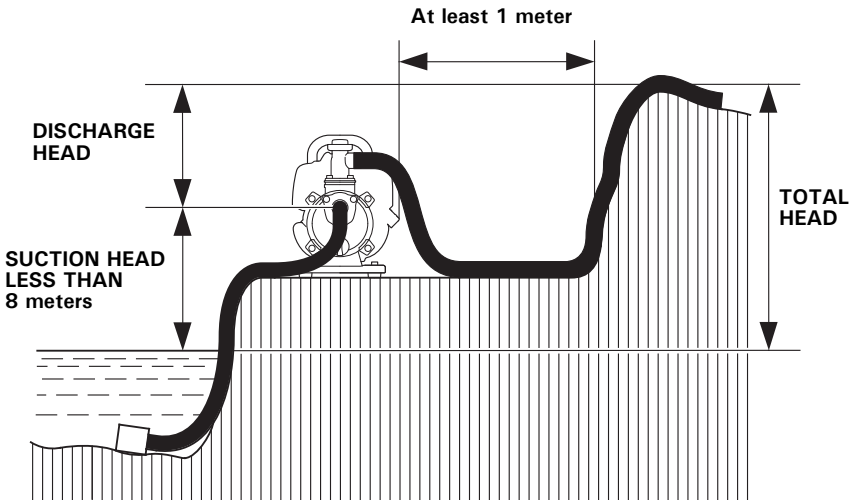

OPERATION

SUCTION HOSE INSTALLATION

Use the hose, hose connector, and hose clamp provided with the pump. The suction hose must be reinforced with a noncollapsible wall or braided wire construction to prevent suction hose collapse.

The suction hose should be no longer than necessary. Pump performance is best when the pump is near the water level, and the hoses are short.

Never use a suction hose with an inside diameter less than 25 mm.

1. Verify that the hose coupling packing is in good condition.
2. Securely tighten the hose connector to the pump suction port.
3. Install the suction hose to the hose connector.

Use a hose clamp to securely fasten the suction hose to the hose connector in order to prevent air leakage and loss of suction.

Install the strainer (provided with the pump) on the other end of the suction hose, and secure it with a hose clamp. The strainer will help to prevent the pump from becoming clogged or damaged by debris.

Never operate the pump without the strainer installed.

NOTICE

Always use the included strainer or one with an equivalent mesh size. Operating the pump without a strainer may result in severe pump damage.

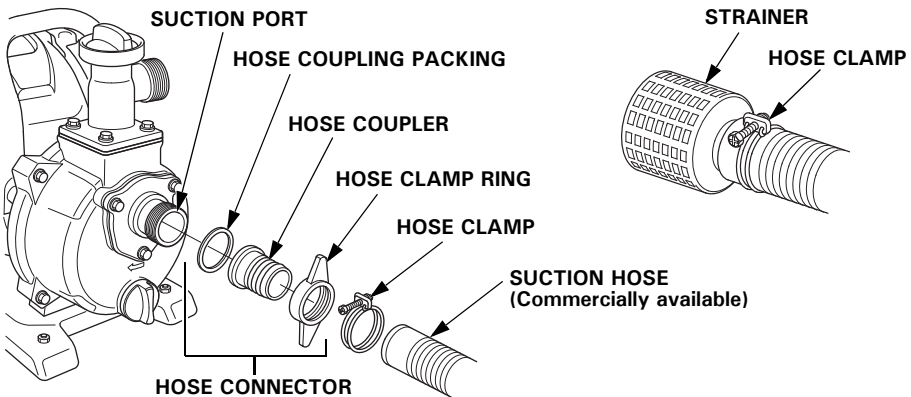

DISCHARGE HOSE INSTALLATION

1. Verify that the hose coupling packing is in good condition.
2. Securely tighten the hose connector to the pump discharge port.
3. Install the discharge hose to the hose connector.

Use a hose clamp to securely fasten the discharge hose to prevent the discharge hose from disconnecting from the hose connector under high pressure.

It is best to use a short, large-diameter hose, because this will reduce fluid friction and improve pump performance. A long or small-diameter hose will increase fluid friction and reduce pump output.

If the discharge hose is equipped with a shutoff valve or nozzle, do not shut off the discharge water for a long period of time, as that could cause the pump to overheat.

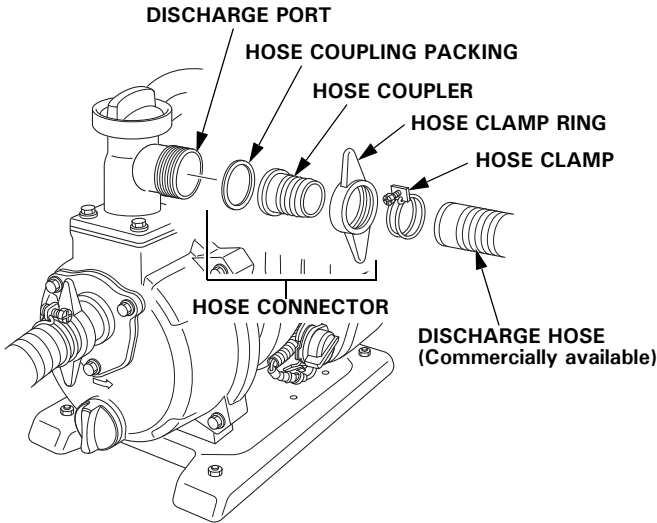

OPERATION

PRIMING THE PUMP

Before starting the engine, remove the filler cap from the pump chamber, and fill the pump chamber with water up to its priming water filling level. Reinstall the filler cap, and tighten it securely.

NOTICE

Operating the pump dry will destroy the pump seal. If the pump has been operated dry, stop the engine immediately, and allow the pump to cool before priming.

PRIMING WATER FILLER CAP

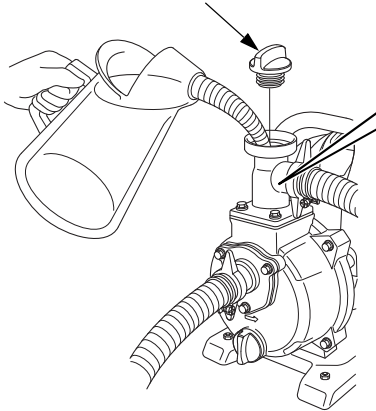

PRIMING WATER FILLING LEVEL

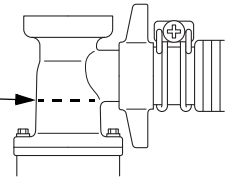

If the discharge hose must run across a roadway, the hose should cross the roadway perpendicular to traffic flow. Also, heavy boards should be placed next to the hose so the motor vehicle weight does not shut off the discharge as vehicles cross over the hose.

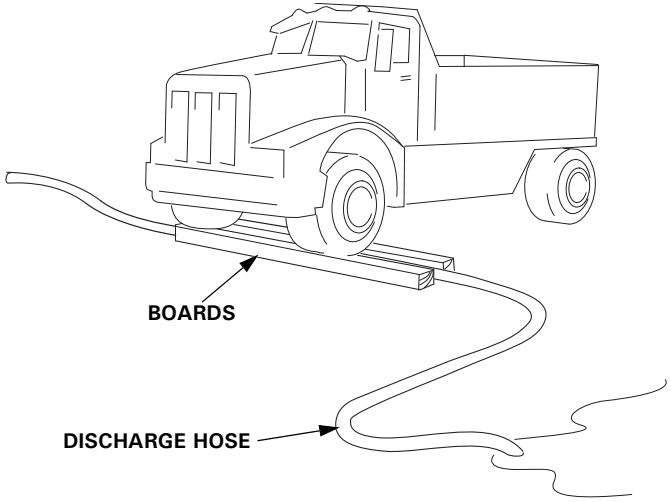

Driving over a discharge hose while the pump is running, or even possibly when the pump is stopped, may cause pump case failure.

OPERATION

STARTING THE ENGINE

1. To start a cold engine, move the choke lever to the CLOSED position.
To restart a warm engine, leave the choke lever in the OPEN position.

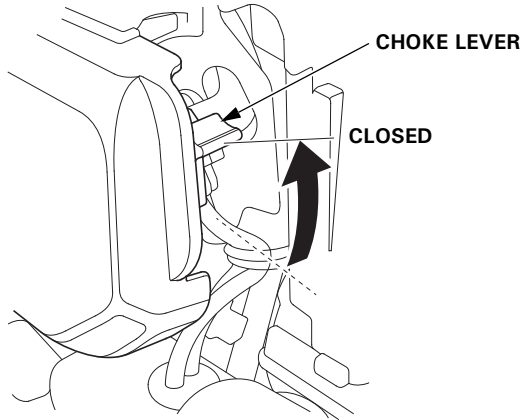

2. Move the throttle lever away from the SLOW position, about 1/3 of the way toward the FAST position.

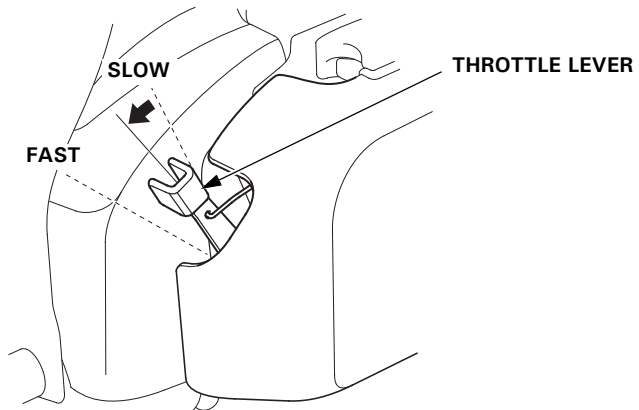

3. Press the priming pump repeatedly until fuel can be seen in the clear-plastic fuel return tube.

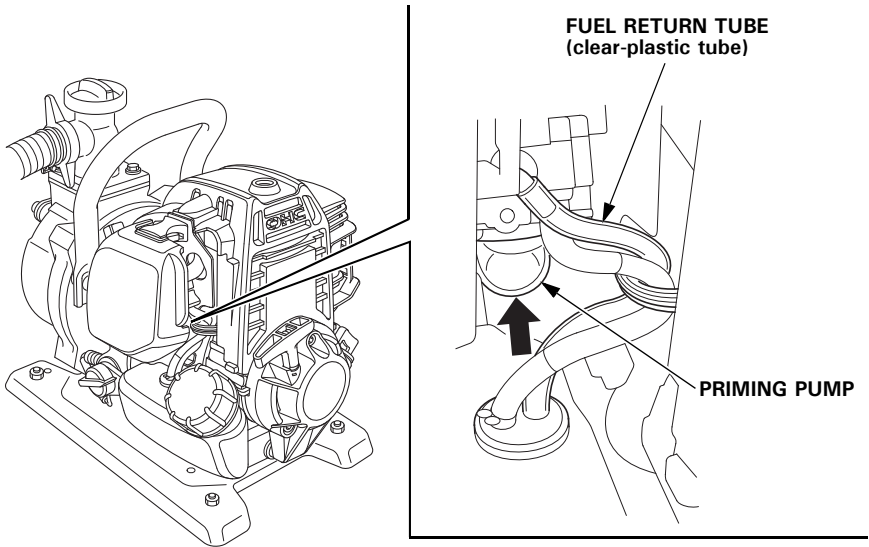

4. Turn the ignition switch to the ON position.

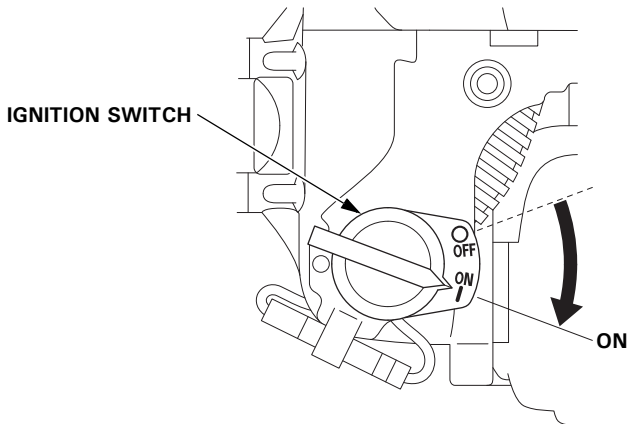

OPERATION

5. Hold the carrying handle securely and pull the starter grip lightly until you feel resistance, then pull briskly in the direction of the arrow as shown below.

Do not allow the recoil starter grip to snap back against the engine. Return it gently to prevent damage to the starter.

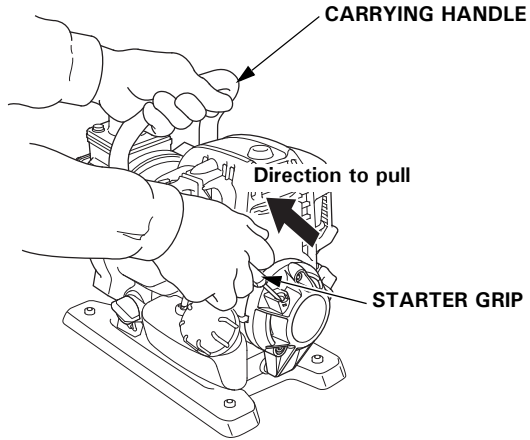

6. If the choke lever was moved to the CLOSED position to start the engine, gradually move it to the OPEN position as the engine warms up.

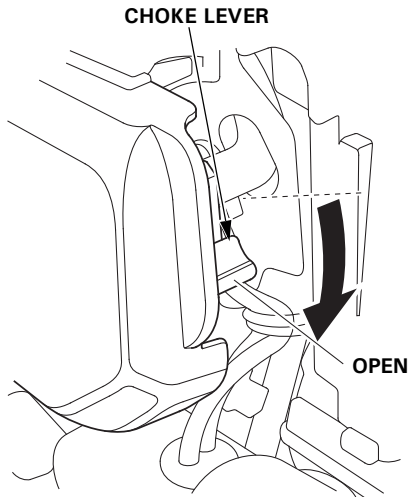

SETTING ENGINE SPEED

After starting the engine, move the throttle lever to the FAST position for self-priming, and check pump output.

Pump output is controlled by adjusting engine speed. Moving the throttle lever in the FAST direction will increase pump output, and moving the throttle lever in the SLOW direction will decrease pump output.

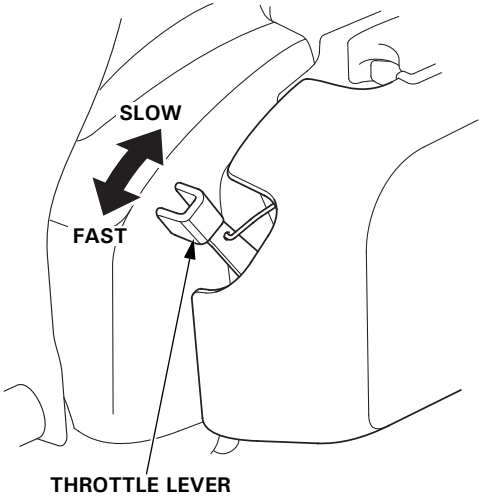

OPERATION

STOPPING THE ENGINE

To stop the engine in an emergency, simply turn the ignition switch to the OFF position. Under normal conditions, use the following procedure.

1. Move the throttle lever to the SLOW position.

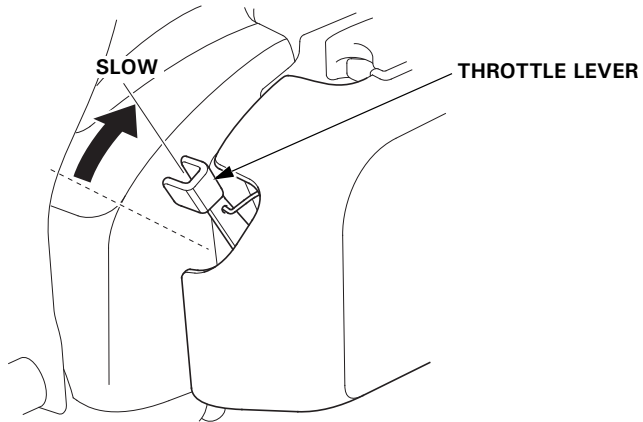

2. Turn the ignition switch to the OFF position.

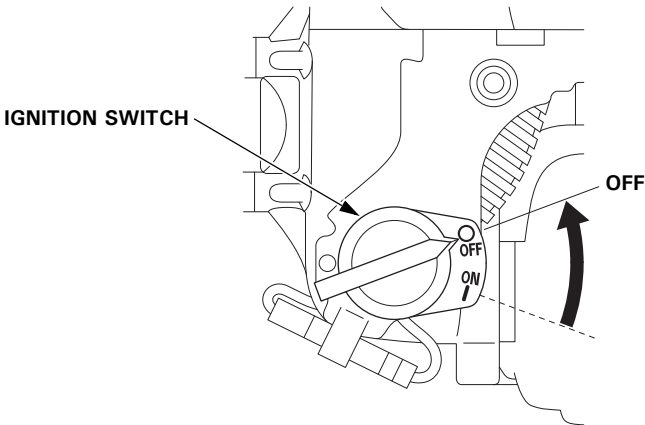

After use, remove the pump drain plug (see page 46), and drain the pump chamber. Remove the filler cap, and flush the pump chamber with clean, fresh water. Allow the water to drain from the pump chamber, and then reinstall the filler cap and drain plug.

SERVICING YOUR PUMP

THE IMPORTANCE OF MAINTENANCE

Good maintenance is essential for safe, economical, and trouble-free operation. It will also help reduce air pollution.

⚠ WARNING

Improperly maintaining this pump, or failure to correct a problem before operation, can cause a malfunction in which you can be seriously hurt or killed.

Always follow the inspection and maintenance recommendations and schedules in this owner's manual.

To help you properly care for your pump, the following pages include a maintenance schedule, routine inspection procedures, and simple maintenance procedures using basic hand tools. Other service tasks that are more difficult, or require special tools, are best handled by professionals and are normally performed by a Honda technician or other qualified mechanic.

The maintenance schedule applies to normal operating conditions. If you operate your pump under severe conditions, such as sustained high-load or high-temperature operation, or use in unusually wet or dusty conditions, consult your servicing dealer for recommendations applicable to your individual needs and use.

Remember that an authorized Honda servicing dealer knows your pump best and is fully equipped to maintain and repair it.

To ensure the best quality and reliability, use only new, Honda Genuine parts or their equivalents for repair and replacement.

SERVICING YOUR PUMP

MAINTENANCE SAFETY

Some of the most important safety precautions follow. However, we cannot warn you of every conceivable hazard that can arise in performing maintenance. Only you can decide whether or not you should perform a given task.

⚠ WARNING

Failure to properly follow maintenance instructions and precautions can cause you to be seriously hurt or killed.

Always follow the procedures and precautions in the owner's manual.

Safety Precautions

- Make sure the engine is off before you begin any maintenance or repairs. This will eliminate several potential hazards:
 - **Carbon monoxide poisoning from engine exhaust.**
Operate outside away from open windows or doors.
 - **Burns from hot parts.**
Let the engine and exhaust system cool before touching.
 - **Injury from moving parts.**
Do not run the engine unless instructed to do so.
- Read the instructions before you begin, and make sure you have the tools and skills required.
- To reduce the possibility of fire or explosion, be careful when working around gasoline. Use only a nonflammable solvent, not gasoline, to clean parts. Keep cigarettes, sparks, and flames away from all fuel-related parts.

SERVICING YOUR PUMP

MAINTENANCE SCHEDULE

| REGULAR SERVICE PERIOD (3) | | Each use | First month or 10 hrs. | Every 3 months or 25 hrs. | Every 6 months or 50 hrs. | Every year or 100 hrs. | Every 2 years or 300 hrs. | Refer to page |
|----------------------------|---|--|------------------------|---------------------------|---------------------------|------------------------|---------------------------|---------------|
| ITEM | Perform at every indicated month or operating hour interval, whichever comes first. | | | | | | | |
| Engine oil | Check level | o | | | | | | 30 |
| | Change | | o | | o | | | 31 |
| Air cleaner | Check | o | | | | | | 34 |
| | Clean | | | o (1) | | | | 35 |
| Nuts, bolts, fasteners | Check (Retighten if necessary) | o | | | | | | — |
| Spark plug | Check-adjust | | | | | o | | 36 |
| | Replace | | | | | | o | |
| Engine cooling fins | Clean | | | | o | | | 39 |
| Spark arrester | Clean | | | | | o | | 43 |
| Fuel tank | Clean | | | | | o | | 40 |
| Fuel filter | Clean | | | | | o | | 40 |
| Idle speed | Check-adjust | | | | | o (2) | | — |
| Valve clearance | Check-adjust | | | | | o (2) | | — |
| Combustion chamber | Clean | After every 300 hrs. (2) | | | | | | — |
| Fuel tube | Check | Every 2 years (Replace if necessary) (2) | | | | | | 42 |
| Oil tube | Check | Every 2 years (Replace if necessary) (2) | | | | | | — |
| Impeller | Check | | | | | o (2) | | — |
| Impeller clearance | Check | | | | | o (2) | | — |
| Pump inlet valve | Check | | | | | o (2) | | — |

- (1) Service more frequently when used in dusty areas.
- (2) These items should be serviced by your servicing dealer, unless you have the proper tools and are mechanically proficient. Refer to the Honda shop manual for service procedures.
- (3) For commercial use, log hours of operation to determine proper maintenance intervals.

Failure to follow this maintenance schedule could result in non-warrantable failures.

SERVICING YOUR PUMP

REFUELING

Check the fuel level by looking through the translucent fuel tank. If the fuel level is low, refuel in a well-ventilated area with the engine stopped. If the engine has been running, allow it to cool first. Never refuel the engine inside a building where gasoline fumes can reach flames or sparks.

⚠ WARNING

Gasoline is highly flammable and explosive.

You can be burned or seriously injured when handling fuel.

- Stop the engine and keep heat, sparks, and flame away.
- Handle fuel only outdoors.
- Wipe up spills immediately.

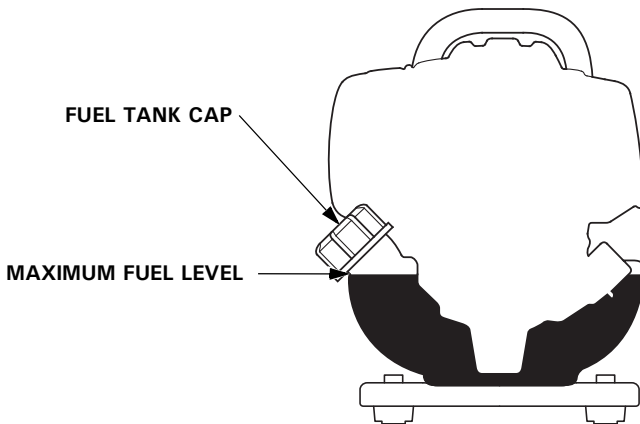

To refuel, rest the engine on the ground with the fuel tank cap facing up, as shown. Remove the fuel tank cap, and fill the tank with gasoline to the maximum fuel level. Refuel carefully to avoid spilling fuel. Do not overfill. There should no fuel in the filler neck. After refueling, tighten the fuel tank cap securely.

Spilled fuel is not only a fire hazard, it causes environmental damage. Wipe up spills immediately.

NOTICE

Fuel can damage paint and plastic. Be careful not to spill fuel when filling your fuel tank. Damage caused by spilled fuel is not covered under warranty.

FUEL RECOMMENDATIONS

This engine is certified to operate on regular unleaded gasoline with a Research Octane Number of 91 or higher (a Pump Octane Rating of 86 or higher).

Never use stale or contaminated gasoline or an oil/gasoline mixture. Avoid getting dirt or water in the fuel tank.

You may use regular unleaded gasoline containing no more than 10% ethanol (E10) or 5% methanol by volume. In addition, methanol must contain cosolvents and corrosion inhibitors.

Use of fuels with content of ethanol or methanol greater than shown above may cause starting and/or performance problems. It may also damage metal, rubber, and plastic parts of the fuel system.

Engine damage or performance problems that result from using a fuel with percentages of ethanol or methanol greater than shown above are not covered under warranty.

If your equipment will be used on an infrequent or intermittent basis, please refer to the fuel section of the *STORAGE* chapter (see page 47) for additional information regarding fuel deterioration.

SERVICING YOUR PUMP

ENGINE OIL LEVEL CHECK

Check the engine oil level before each use, or every 10 hours if operated continuously.

Check the engine oil level with the engine stopped and in a level position.

1. Remove the oil filler cap.
2. Check the oil level. If it is below the upper limit, fill with the recommended oil (see page 33) to the upper limit.

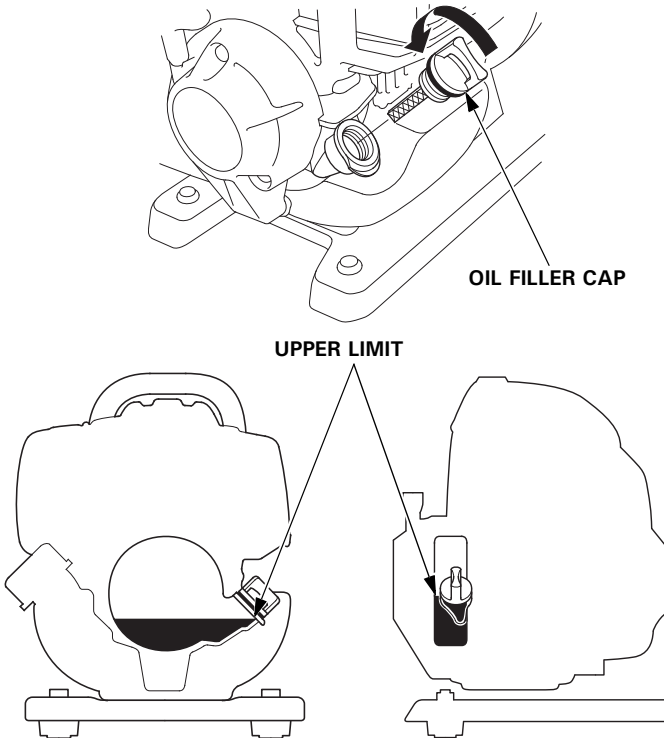

3. Reinstall the oil filler cap securely.

NOTICE

Running the engine with a low or excessive oil level can cause engine damage. This type of damage is not covered by warranty.

ENGINE OIL CHANGE

Drain the used oil while the engine is warm. Warm oil drains quickly and completely.

1. Check that the fuel tank cap is tightened securely.
2. Place a suitable container next to the engine to catch the used oil.
3. Remove the oil filler cap and drain the oil into the container by tipping the engine toward the oil filler neck.

Please dispose of used motor oil in a manner that is compatible with the environment. We suggest you take used oil in a sealed container to your local recycling center or service station for reclamation. Do not throw it in the trash, pour it on the ground, or pour it down a drain.

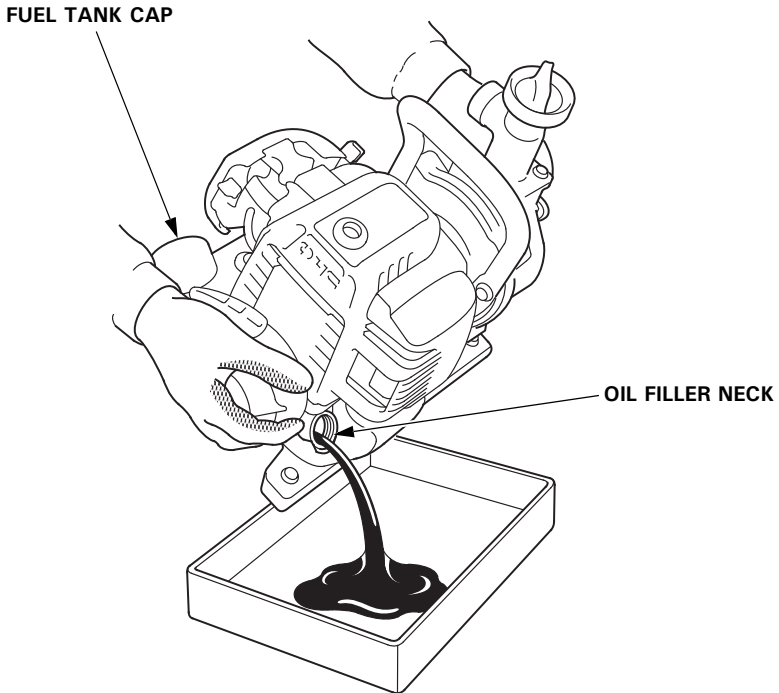

SERVICING YOUR PUMP

4. With the engine in a level position, fill to the upper limit with the recommended oil (see page 33).

Some oil will remain in the engine after draining. When refilling with fresh oil, start with less than 0.08 L. Slowly add enough oil to fill to the upper limit as shown below.

NOTICE

Running the engine with a low or excessive oil level can cause engine damage. This type of damage is not covered by warranty.

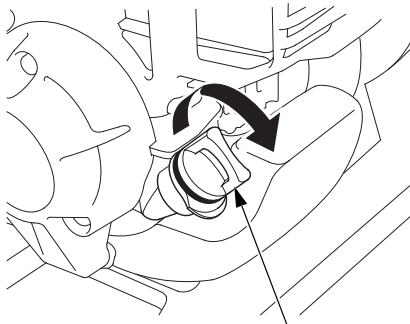
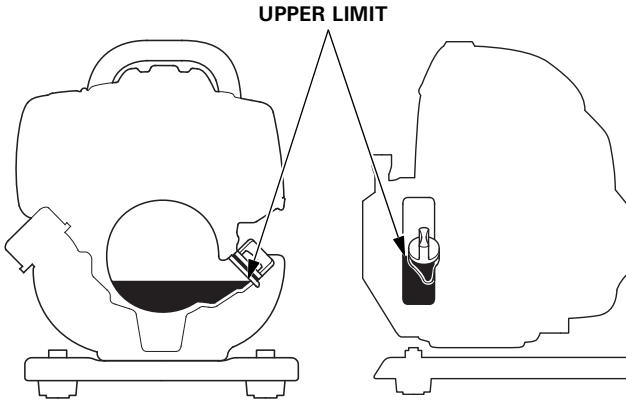

5. Reinstall the oil filler cap securely.
If any oil is spilled, be sure to wipe it.

ENGINE OIL RECOMMENDATIONS

Oil is a major factor affecting performance and service life. Use 4-stroke automotive detergent oil.

Use 4-stroke motor oil that meets or exceeds the requirements for API service category SE or later (or equivalent). Always check the API service label on the oil container to be sure it includes the letters SE or later (or equivalent).

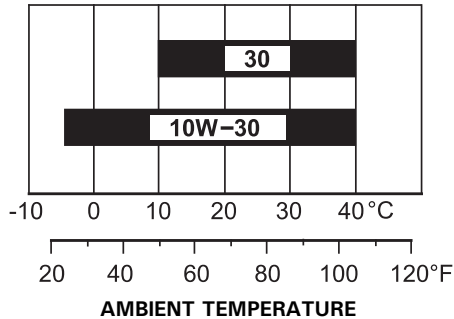

SAE 10W-30 is recommended for general use. Other viscosities shown in the chart may be used when the average temperature in your area is within the indicated range.

SERVICING YOUR PUMP

AIR CLEANER SERVICE

Move the choke lever to the CLOSED (upwards) position (see page 9).

Press the latch tab on the top of the air cleaner cover. Tilt the top of the air cleaner cover back and unhook the two lower tabs, and remove the cover. Check the air filter to be sure it is clean and in good condition.

If the air filter is dirty, clean it as described on page 35. Replace the air filter if it is damaged.

Reinstall the air filter and air cleaner cover.

NOTICE

Operating the engine without an air filter, or with a damaged air filter, will allow dirt to enter the engine, causing rapid engine wear. This type of damage is not covered by the warranty.

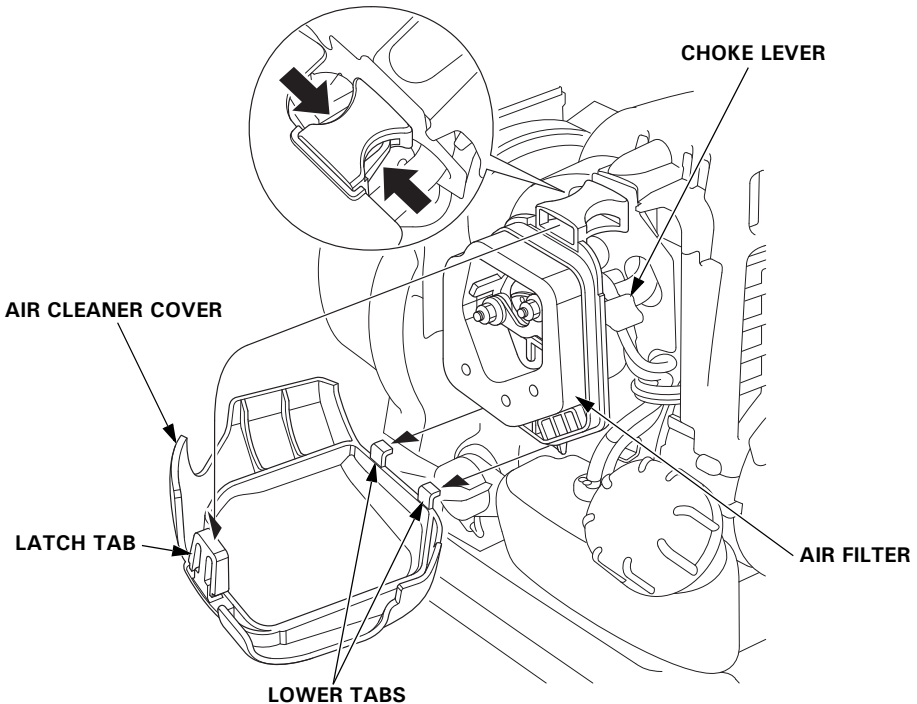

AIR FILTER CLEANING

A dirty air filter will restrict air flow to the carburetor, reducing engine performance. If you operate the pump in very dusty areas, clean the air filter more frequently than specified in the *Maintenance Schedule* (see page 27).

1. Clean the air filter in warm soapy water, rinse, and allow to dry thoroughly. Or clean in nonflammable solvent and allow to dry.
2. Dip the air filter in clean engine oil, and then squeeze out all excess oil. The engine will smoke when started if too much oil is left in the foam.

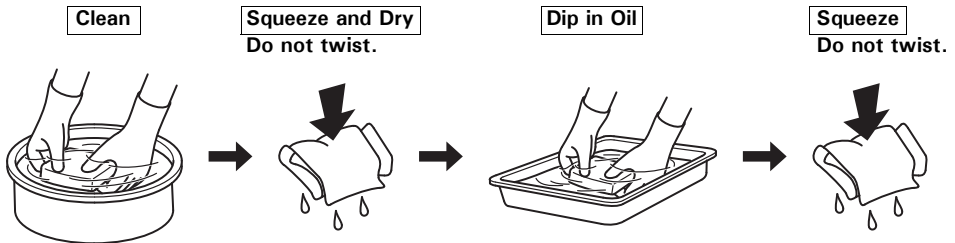

3. Wipe dirt from the air cleaner base and cover, using a moist rag. Be careful to prevent dirt from entering the air duct that leads to the carburetor.

SERVICING YOUR PUMP

SPARK PLUG SERVICE

Recommended spark plug: CMR5H (NGK)

NOTICE

Incorrect spark plugs can cause engine damage.

1. Loosen the 5 mm hex bolt with a hexagon wrench, and then remove the top cover.

⚠ WARNING

- You may be injured from rotating parts or burned by the muffler.
- Do not operate the engine when the top cover is removed.
- Do not pull the recoil starter grip when the top cover is removed.

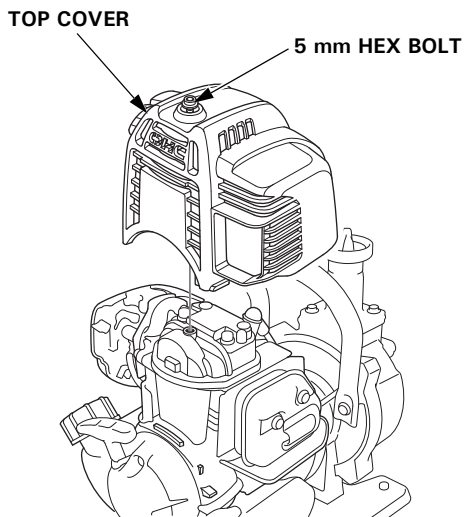

2. First remove any dirt from around the spark plug area, and then disconnect the spark plug cap.
3. Remove the spark plug with a spark plug wrench.

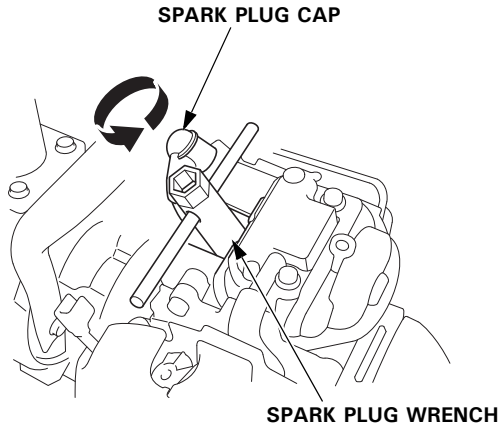

4. Inspect the spark plug. Replace it if the electrodes are worn, or if the insulator is cracked or chipped.
5. Measure the spark plug electrode gap with a wire-type feeler gauge. Correct the gap, if necessary, by carefully bending the side electrode.

The gap should be:
0.6–0.7 mm

6. Install the spark plug carefully, by hand, to avoid cross-threading.

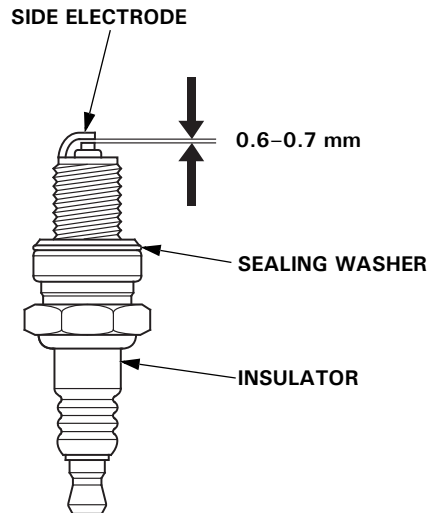

SERVICING YOUR PUMP

7. After the spark plug seats, tighten with a spark plug wrench to compress the washer.

If reinstalling the used spark plug, tighten 1/8–1/4 turn after the spark plug seats.

If installing a new spark plug, tighten 1/2 turn after the spark plug seats.

NOTICE

A loose spark plug can overheat and damage the engine.

Overtightening the spark plug can damage the threads in the cylinder head.

8. Attach the spark plug cap.

9. Install the top cover, and tighten the 5 mm hex bolt securely with the hexagon wrench.

COOLING FIN INSPECTION

1. Remove the top cover (see page 36).
2. Inspect the engine cooling fins, and clean out debris if they are clogged.

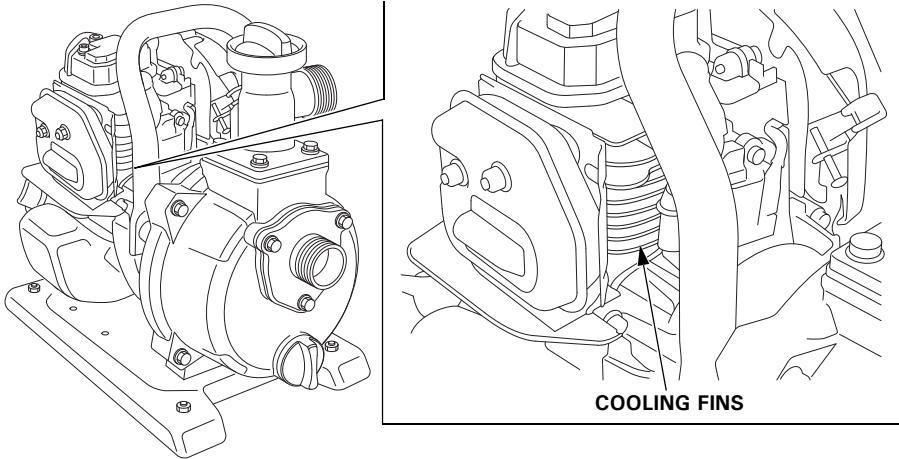

3. Install the top cover, and tighten the 5 mm hex bolt securely with a hexagon wrench.

SERVICING YOUR PUMP

FUEL FILTER INSPECTION and FUEL TANK CLEANING

1. Check that the oil filler cap is tightened securely.
2. Remove the fuel tank cap, and drain the fuel into an approved gasoline container by tipping the engine toward the fuel filler neck.

⚠ WARNING

Gasoline is highly flammable and explosive.

You can be burned or seriously injured when handling fuel.

- Keep heat, sparks, and flame away.
- Handle fuel only outdoors.
- Wipe up spills immediately.

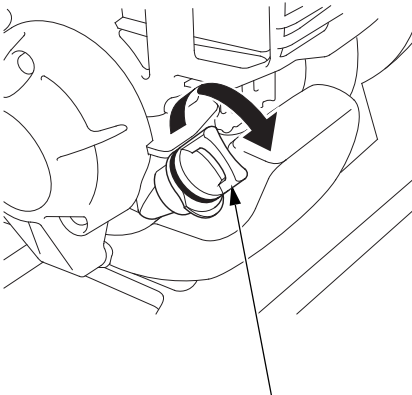

OIL FILLER CAP

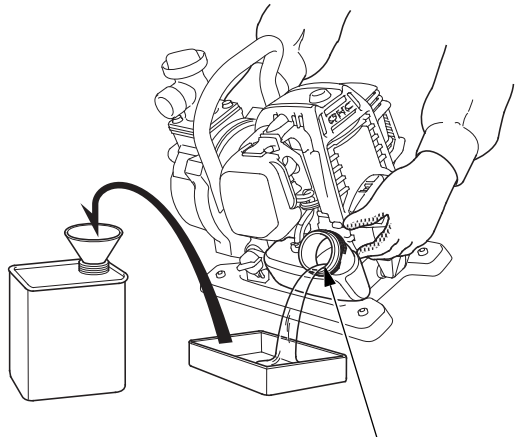

FUEL FILLER NECK

SERVICING YOUR PUMP

3. Pull the fuel filter out through the fuel filler neck by hooking the black fuel tube with a piece of wire, such as a partly straightened paper clip.
4. Inspect the fuel filter. If the fuel filter is dirty, wash it gently with nonflammable or high flashpoint solvent. If the fuel filter is excessively dirty, replace it.

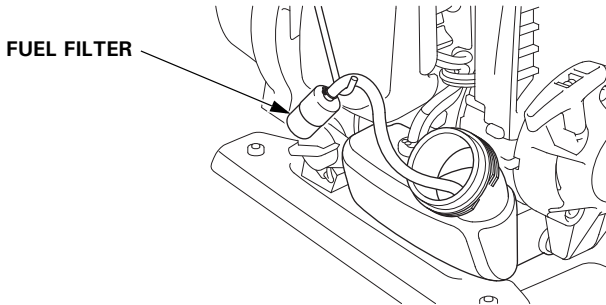

5. Rinse sediment from the fuel tank, using nonflammable or high flashpoint solvent.
6. Insert the fuel filter into the fuel tank and tighten the fuel tank cap securely.

SERVICING YOUR PUMP

FUEL TUBE INSPECTION

Check the fuel supply and return tubes, and replace any tube that is damaged, cracked, stiff, or leaking.

Refer to the Honda shop manual for tube replacement instructions, or take the pump to your pump servicing dealer.

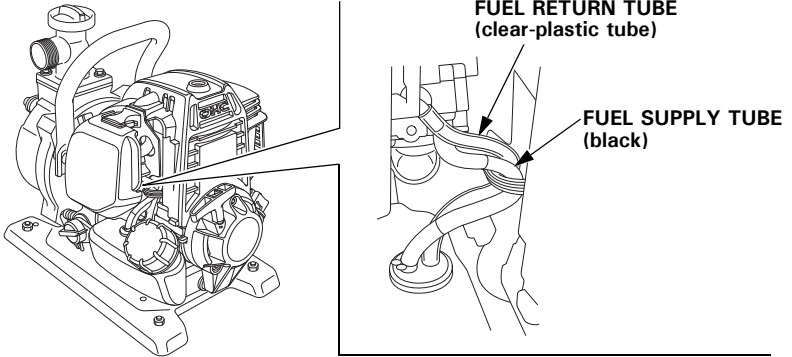

SPARK ARRESTER SERVICE

The spark arrester must be serviced every 100 hours to keep it functioning as designed.

If the engine has been running, the muffler will be very hot. Allow the muffler to cool before servicing the spark arrester.

1. Remove the top cover (see page 36).
2. Remove the two 4 mm screws from the spark arrester, and remove the spark arrester from the muffler.

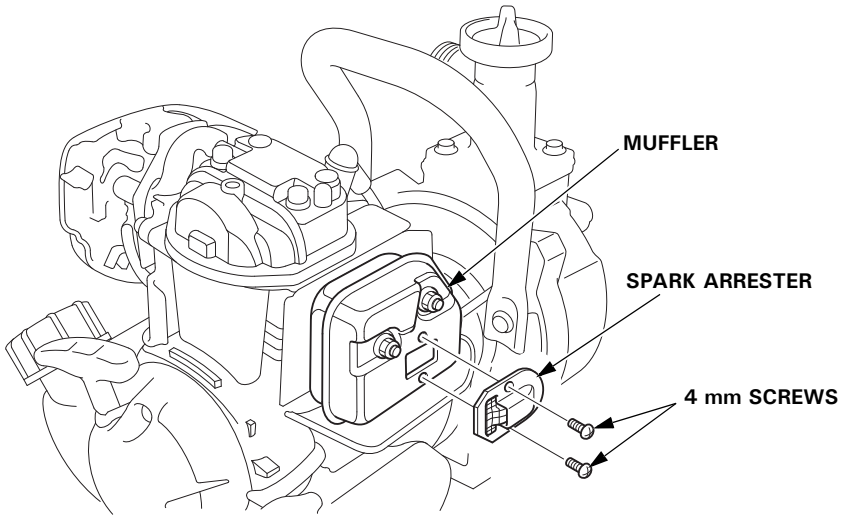

SERVICING YOUR PUMP

3. Use a brush to remove carbon deposits from the spark arrester screen. Be careful to avoid damaging the screen.

The spark arrester must be free of breaks and holes. Replace the spark arrester if it is damaged.

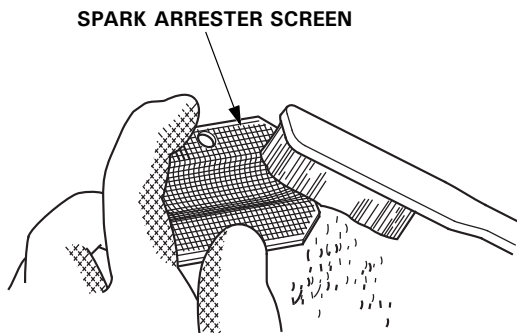

4. Install the spark arrester in the reverse order of disassembly.

When you attach the spark arrester, spark arrester's outlet must be pointed toward the side opposite the spark plug.

5. Install the top cover, and tighten the 5 mm hex bolt securely with a hexagon wrench.

STORAGE

STORAGE PREPARATION

Proper storage preparation is essential for keeping your pump trouble-free and looking good. The following steps will help to keep rust and corrosion from impairing your pump's function and appearance, and will make the engine easier to start when you use the pump again.

Cleaning

1. Wash the engine and pump.

Wash the engine by hand, and be careful to prevent water from entering the air cleaner or muffler opening. Keep water away from controls and all other places that are difficult to dry, as water promotes rust.

NOTICE

- *Using a garden hose or pressure washing equipment can force water into the air cleaner or muffler opening. Water in the air cleaner will soak the air filter, and water that passes through the air filter or muffler can enter the cylinder, causing damage.*
- *Water contacting a hot engine can cause damage. If the engine has been running, allow it to cool for at least half an hour before washing.*

2. Wipe dry all accessible surfaces.

3. Fill the pump chamber with clean, fresh water, start the engine outdoors, and let it run until it reaches normal operating temperature to evaporate any external water.

NOTICE

Dry operation will damage the pump seal. Be sure the pump chamber is filled with water before starting the engine.

STORAGE

4. Stop the engine, and allow it to cool.
5. Remove the pump drain plug, and flush the pump with clean, fresh water. Allow the water to drain from the pump chamber, and then reinstall the drain plug.
6. After the pump is clean and dry, touch up any damaged paint, and coat areas that may rust with a light film of oil. Lubricate controls with a silicone spray lubricant.

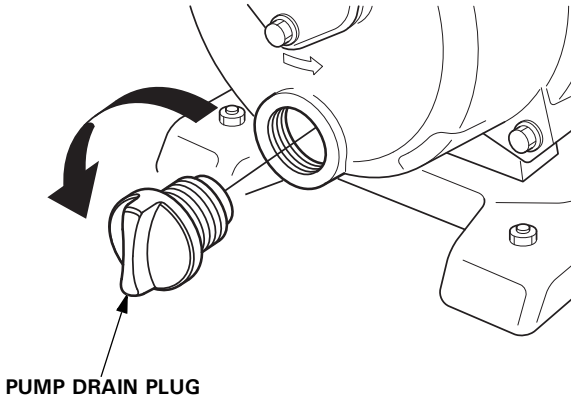

Fuel

NOTICE

Depending on the region where you operate your equipment, fuel formulations may deteriorate and oxidize rapidly. Fuel deterioration and oxidation can occur in as little as 30 days and may cause damage to the carburetor and/or fuel system. Please check with your servicing dealer for local storage requirements.

Gasoline will oxidize and deteriorate in storage. Old gasoline will cause hard starting, and it leaves gum deposits that clog the fuel system. If the gasoline in your engine deteriorates during storage, you may need to have the carburetor and other fuel system components serviced or replaced.

The length of time that gasoline can be left in your fuel tank and carburetor without causing functional problems will vary with such factors as gasoline blend, your storage temperatures, and whether the fuel tank is partially or completely filled. The air in a partially filled fuel tank promotes fuel deterioration. Very warm storage/temperatures accelerate fuel deterioration. Fuel deterioration problems may occur within a few months, or even less if the gasoline was not fresh when you filled the fuel tank.

The warranty does not cover fuel system damage or engine performance problems resulting from neglected storage preparation.

STORAGE

Draining the Fuel Tank and Carburetor

1. Check that the oil filler cap is tightened securely.
2. Remove the fuel tank cap and drain the fuel into an approved gasoline container by tipping the engine toward the fuel filler neck.
3. Press the priming pump several times until there is no more fuel in the clear-plastic fuel return tube.
4. Tip the engine toward the fuel filler neck again to drain the fuel.

⚠ WARNING

Gasoline is highly flammable and explosive.

You can be burned or seriously injured when handling fuel.

- Keep heat, sparks, and flame away.
- Handle fuel only outdoors.
- Wipe up spills immediately.

FUEL RETURN TUBE
(clear-plastic tube)

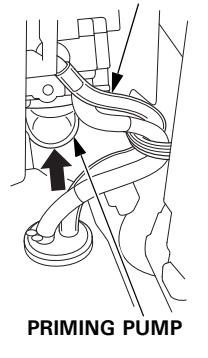

OIL FILLER CAP

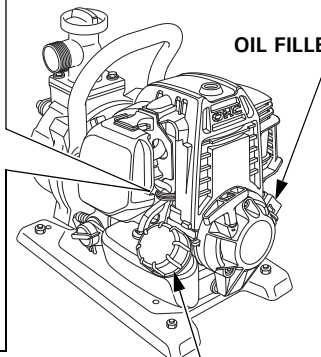

FUEL TANK CAP

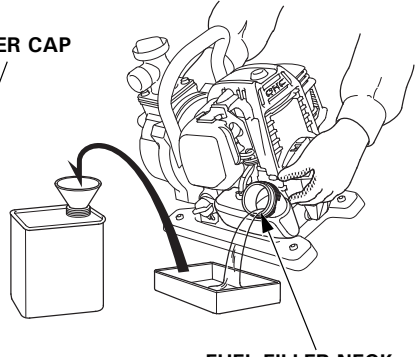

FUEL FILLER NECK

5. After all fuel has drained, reinstall the fuel tank cap securely.

Engine Oil

Change the engine oil (see page 31).

Engine Cylinder

1. Remove the top cover (see page 36).
2. Remove the spark plug (see page 37).
3. Apply a couple of drops of clean engine oil into the cylinder.
4. Install the top cover temporarily.
5. Pull the starter grip several times to distribute the oil in the cylinder.
6. Remove the top cover, and then reinstall the spark plug.
7. Install the top cover, and tighten the 5 mm hex bolt securely with a hexagon wrench.
8. Move the choke lever to the CLOSED (upwards) position (see page 9).
9. Pull the starter grip slowly until resistance is felt. This will close the valves, so moisture cannot enter the engine cylinder. Return the starter grip gently.

STORAGE

STORAGE PRECAUTIONS

If your pump will be stored with gasoline in the fuel tank and carburetor, it is important to reduce the hazard of gasoline vapor ignition. Select a well-ventilated storage area away from any appliance that operates with a flame, such as a furnace, water heater, or clothes dryer. Also avoid any area with a spark-producing electric motor or where power tools are operated.

If possible, avoid storage areas with high humidity, because that promotes rust and corrosion.

Place the pump on a level surface. Tilting can cause fuel or oil leakage.

With the engine and exhaust system cool, cover the pump to keep out dust. A hot engine and exhaust system can ignite or melt some materials. Do not use sheet plastic as a dust cover. A nonporous cover will trap moisture around the pump, promoting rust and corrosion.

REMOVAL FROM STORAGE

Check your pump as described in the *BEFORE OPERATION* chapter of this manual.

If the fuel was drained during storage preparation, fill the tank with fresh gasoline. If you keep a container of gasoline for refueling, be sure that it contains only fresh gasoline. Gasoline oxidizes and deteriorates over time, causing hard starting.

If the cylinder was coated with oil during storage preparation, the engine may smoke briefly at startup. This is normal.

TRANSPORTING

If the pump has been running, allow the engine to cool for at least 15 minutes before loading the pump on the transport vehicle. A hot engine and exhaust system can burn you and can ignite some materials.

Keep the pump level when transporting to reduce the possibility of fuel leakage.

TAKING CARE OF UNEXPECTED PROBLEMS

ENGINE

Engine Will Not Start

| Possible Cause | Correction |
|---|---|
| Choke open. | Move choke lever to CLOSED position unless engine is warm. |
| Ignition switch OFF. | Turn ignition switch to the ON position. |
| Out of fuel. | Refuel (see page 28). |
| Bad fuel; pump stored without treating or draining gasoline, or refueled with bad gasoline. | Drain fuel tank and carburetor (see page 48). Refuel with fresh gasoline (see page 28). |
| Spark plug faulty, fouled, or improperly gapped. | Gap or replace spark plug (see page 37). |
| Spark plug wet with fuel (flooded engine). | Dry and reinstall spark plug. Start engine with throttle lever in FAST position, with choke lever in OPEN position. |
| Fuel filter clogged, carburetor malfunction, ignition malfunction, valves stuck, etc. | Take the pump to your servicing dealer, or refer to shop manual. |

Engine Lacks Power

| Possible Cause | Correction |
|---|--|
| Throttle lever not in the FAST position. | Move the throttle lever to the FAST position (see page 23). |
| Air filter element clogged. | Clean or replace air filter element (see page 35). |
| Bad fuel; pump stored without treating or draining gasoline, or refueled with bad gasoline. | Drain fuel tank and carburetor (see page 48). Refuel with fresh gasoline (see page 28). |
| Fuel filter clogged, carburetor malfunction, ignition malfunction, valves stuck, etc. | Take the pump to your servicing dealer, or refer to shop manual. |

TAKING CARE OF UNEXPECTED PROBLEMS

PUMP

No Pump Output

| Possible Cause | Correction |
|--|---|
| Throttle lever not in the FAST position. | Move the throttle lever to the FAST position (see page 23). |
| Pump not primed. | Prime pump (see page 18). |
| Suction hose collapsed, cut, or punctured. | Replace suction hose (see page 16). |
| Strainer not completely underwater. | Sink the strainer and the end of the suction hose completely underwater. |
| Air leak at connector. | Replace hose coupling packing if missing or damaged. Tighten hose connector and clamp (see pages 16 and 17). |
| Strainer clogged. | Clean debris from strainer. |
| Excessive head. | Relocate pump and/or hoses to reduce head (see page 15). |
| Engine lacks power. | See page 52. |

Low Pump Output

| Possible Cause | Correction |
|---|---|
| Throttle lever not in the FAST position. | Move the throttle lever to the FAST position (see page 23). |
| Suction hose collapsed, damaged, too long, or diameter too small. | Replace suction hose (see page 16). |
| Air leak at connector. | Replace hose coupling packing if missing or damaged. Tighten hose connector and clamp (see pages 16 and 17). |
| Strainer clogged. | Clean debris from strainer. |
| Discharge hose damaged, too long, or diameter too small. | Replace discharge hose (see page 17). |
| Excessive head. | Relocate pump and/or hoses to reduce head (see page 15). |
| Engine lacks power. | See page 52. |

TECHNICAL INFORMATION

Serial Number Locations

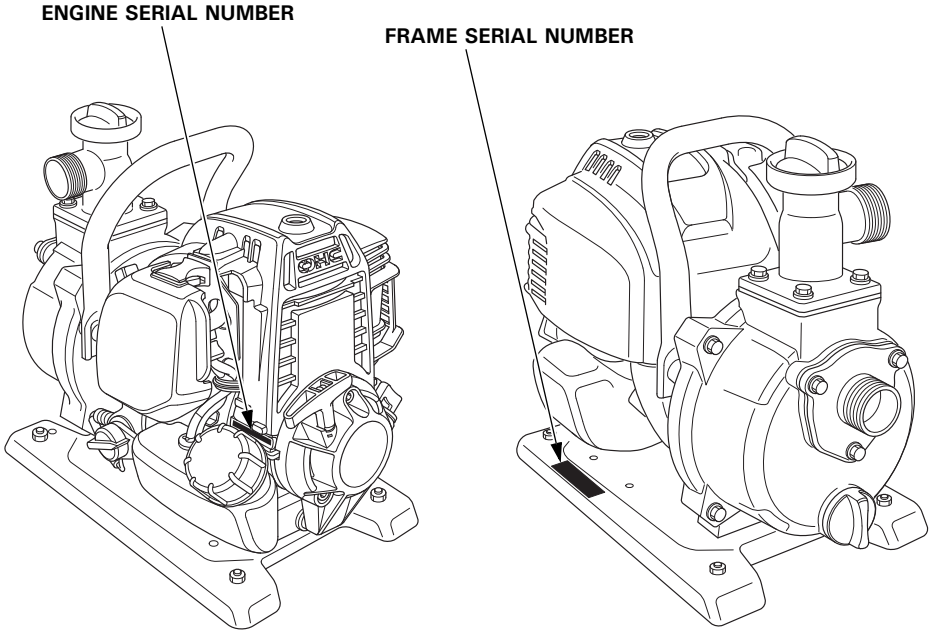

Record the frame serial number and the engine serial number in the space below. You will need these serial numbers when ordering parts, and when making technical or warranty inquiries.

Engine serial number: _____

Frame serial number: _____

Date of purchased: _____

Carburetor Modification for High Altitude Operation

At high altitude, the standard carburetor air-fuel mixture will be too rich. Performance will decrease, and fuel consumption will increase. A very rich mixture will also foul the spark plug and cause hard starting. Operation at an altitude that differs from that at which this engine was certified, for extended periods of time, may increase emissions.

High altitude performance can be improved by specific modifications to the carburetor. If you always operate your pump at altitudes above 1,500 meters, have your servicing dealer perform this carburetor modification. This engine, when operated at high altitude with the carburetor modifications for high altitude use, will meet each emission standard throughout its useful life.

Even with carburetor modification, engine horsepower will decrease about 3.5% for each 300 meter increase in altitude. The effect of altitude on horsepower will be greater than this if no carburetor modification is made.

NOTICE

When the carburetor has been modified for high altitude operation, the air-fuel mixture will be too lean for low altitude use. Operation at altitudes below 1,500 meters with a modified carburetor may cause the engine to overheat and result in serious engine damage. For use at low altitudes, have your servicing dealer return the carburetor to original factory specifications.

TECHNICAL INFORMATION

Specifications

Dimensions and weight

| | |
|-------------------|--------|
| Length | 340 mm |
| Width | 220 mm |
| Height | 295 mm |
| Dry mass [weight] | 6.1 kg |

Engine design and performance

| | |
|---------------------------------|--|
| Model | GX25T |
| Engine type | 4-stroke, overhead camshaft, single cylinder |
| Displacement [bore × stroke] | 25.0 cm ³ 35.0 × 26.0 mm |
| Engine oil capacity | 0.08 L |
| Fuel tank capacity | 0.53 L |
| Cooling system | Forced air |
| Ignition system | Transistor magneto |
| PTO shaft rotation | Counterclockwise |

Tune up

| | | |
|---------------------------|---|---|
| Spark plug gap | 0.6–0.7 mm | Refer to page 37. |
| Idle speed | 3,100 ± 200 rpm | |
| Valve clearance (cold) | Intake: 0.08 ± 0.02 mm Exhaust: 0.11 ± 0.02 mm | See your authorized Honda dealer. |
| Other specifications | No other adjustments needed. | |

Pump

| | |
|------------------------------|-------------------|
| Suction port diameter | 25 mm |
| Discharge port diameter | 25 mm |
| Total head (maximum) | 37 m |
| Suction head (maximum) | 8 m |
| Discharge capacity (maximum) | 120 L per minute |
| Self-priming time | 80 seconds at 5 m |

Specifications are subject to change without notice.

CONSUMER INFORMATION

Australia Distributor Information

| NAME OF FIRM (COMPANY) | ADDRESS | TEL: FAX: |
|--|--|--|
| Honda Australia Motorcycle and Power Equipment Pty. Ltd. | 1954-1956 Hume Highway Campbellfield Victoria 3061 | Tel: (03) 9270 1111 Fax: (03) 9270 1133 |

MEMO

MEMO

MEMO